

ISSN 2518-170X (Online),  
ISSN 2224-5278 (Print)

ҚАЗАҚСТАН РЕСПУБЛИКАСЫ  
ҰЛТТЫҚ ҒЫЛЫМ АКАДЕМИЯСЫНЫҢ  
Satbayev University

# Х А Б А Р Л А Р Ы

---

---

## ИЗВЕСТИЯ

НАЦИОНАЛЬНОЙ АКАДЕМИИ НАУК  
РЕСПУБЛИКИ КАЗАХСТАН  
Satbayev University

## NEWS

OF THE ACADEMY OF SCIENCES  
OF THE REPUBLIC OF KAZAKHSTAN  
Satbayev University

**SERIES**  
**OF GEOLOGY AND TECHNICAL SCIENCES**

**2 (440)**

**MARCH – APRIL 2020**

THE JOURNAL WAS FOUNDED IN 1940

PUBLISHED 6 TIMES A YEAR

ALMATY, KAZAKHSTAN

---

---

*NAS RK is pleased to announce that News of NAS RK. Series of geology and technical sciences scientific journal has been accepted for indexing in the Emerging Sources Citation Index, a new edition of Web of Science. Content in this index is under consideration by Clarivate Analytics to be accepted in the Science Citation Index Expanded, the Social Sciences Citation Index, and the Arts & Humanities Citation Index. The quality and depth of content Web of Science offers to researchers, authors, publishers, and institutions sets it apart from other research databases. The inclusion of News of NAS RK. Series of geology and technical sciences in the Emerging Sources Citation Index demonstrates our dedication to providing the most relevant and influential content of geology and engineering sciences to our community.*

*Қазақстан Республикасы Ұлттық ғылым академиясы "ҚР ҰҒА Хабарлары. Геология және техникалық ғылымдар сериясы" ғылыми журналының Web of Science-тің жаңаланған нұсқасы Emerging Sources Citation Index-те индекстелуге қабылданғанын хабарлайды. Бұл индекстелу барысында Clarivate Analytics компаниясы журналды одан әрі the Science Citation Index Expanded, the Social Sciences Citation Index және the Arts & Humanities Citation Index-ке қабылдау мәселесін қарастыруда. Web of Science зерттеушілер, авторлар, баспашылар мен мекемелерге контент тереңдігі мен сапасын ұсынады. ҚР ҰҒА Хабарлары. Геология және техникалық ғылымдар сериясы Emerging Sources Citation Index-ке енуі біздің қоғамдастық үшін ең өзекті және беделді геология және техникалық ғылымдар бойынша контентке адалдығымызды білдіреді.*

*НАН РК сообщает, что научный журнал «Известия НАН РК. Серия геологии и технических наук» был принят для индексирования в Emerging Sources Citation Index, обновленной версии Web of Science. Содержание в этом индексировании находится в стадии рассмотрения компанией Clarivate Analytics для дальнейшего принятия журнала в the Science Citation Index Expanded, the Social Sciences Citation Index и the Arts & Humanities Citation Index. Web of Science предлагает качество и глубину контента для исследователей, авторов, издателей и учреждений. Включение Известия НАН РК. Серия геологии и технических наук в Emerging Sources Citation Index демонстрирует нашу приверженность к наиболее актуальному и влиятельному контенту по геологии и техническим наукам для нашего сообщества.*

Б а с р е д а к т о р ы  
э. ғ. д., профессор, ҚР ҰҒА академигі

**И.К. Бейсембетов**

Бас редакторының орынбасары

**Жолтаев Г.Ж.** проф., геол.-мин. ғ. докторы

Р е д а к ц и я а л қ а с ы:

**Абаканов Т.Д.** проф. (Қазақстан)  
**Абишева З.С.** проф., академик (Қазақстан)  
**Агабеков В.Е.** академик (Беларусь)  
**Алиев Т.** проф., академик (Әзірбайжан)  
**Бакиров А.Б.** проф., (Қырғызстан)  
**Беспәев Х.А.** проф. (Қазақстан)  
**Бишимбаев В.К.** проф., академик (Қазақстан)  
**Буктуков Н.С.** проф., академик (Қазақстан)  
**Булат А.Ф.** проф., академик (Украина)  
**Ганиев И.Н.** проф., академик (Тәжікстан)  
**Грэвис Р.М.** проф. (АҚШ)  
**Ерғалиев Г.К.** проф., академик (Қазақстан)  
**Жуков Н.М.** проф. (Қазақстан)  
**Кенжалиев Б.К.** проф. (Қазақстан)  
**Қожахметов С.М.** проф., академик (Қазақстан)  
**Конторович А.Э.** проф., академик (Ресей)  
**Курскеев А.К.** проф., академик (Қазақстан)  
**Курчавов А.М.** проф., (Ресей)  
**Медеу А.Р.** проф., академик (Қазақстан)  
**Мұхамеджанов М.А.** проф., корр.-мүшесі (Қазақстан)  
**Нигматова С.А.** проф. (Қазақстан)  
**Оздоев С.М.** проф., академик (Қазақстан)  
**Постолатий В.** проф., академик (Молдова)  
**Ракишев Б.Р.** проф., академик (Қазақстан)  
**Сейтов Н.С.** проф., корр.-мүшесі (Қазақстан)  
**Сейтмуратова Э.Ю.** проф., корр.-мүшесі (Қазақстан)  
**Степанец В.Г.** проф., (Германия)  
**Хамфери Дж.Д.** проф. (АҚШ)  
**Штейнер М.** проф. (Германия)

«ҚР ҰҒА Хабарлары. Геология және техникалық ғылымдар сериясы».

**ISSN 2518-170X (Online),**

**ISSN 2224-5278 (Print)**

Меншіктенуші: «Қазақстан Республикасының Ұлттық ғылым академиясы» РҚБ (Алматы қ.).

Қазақстан республикасының Мәдениет пен ақпарат министрлігінің Ақпарат және мұрағат комитетінде 30.04.2010 ж. берілген №10892-Ж мерзімдік басылым тіркеуіне қойылу туралы куәлік.

Мерзімділігі: жылына 6 рет.

Тиражы: 300 дана.

Редакцияның мекенжайы: 050010, Алматы қ., Шевченко көш., 28, 219 бөл., 220, тел.: 272-13-19, 272-13-18,  
<http://www.geolog-technical.kz/index.php/en/>

---

© Қазақстан Республикасының Ұлттық ғылым академиясы, 2020

Редакцияның Қазақстан, 050010, Алматы қ., Қабанбай батыр көш., 69а.

мекенжайы: Қ. И. Сәтбаев атындағы геология ғылымдар институты, 334 бөлме. Тел.: 291-59-38.

Типографияның мекенжайы: «NurNaz GRACE», Алматы қ., Рысқұлов көш., 103.

Г л а в н ы й р е д а к т о р  
д. э. н., профессор, академик НАН РК

**И. К. Бейсембетов**

Заместитель главного редактора

**Жолтаев Г.Ж.** проф., доктор геол.-мин. наук

Р е д а к ц и о н н а я к о л л е г и я:

**Абаканов Т.Д.** проф. (Казахстан)  
**Абишева З.С.** проф., академик (Казахстан)  
**Агабеков В.Е.** академик (Беларусь)  
**Алиев Т.** проф., академик (Азербайджан)  
**Бакиров А.Б.** проф., (Кыргызстан)  
**Беспаяев Х.А.** проф. (Казахстан)  
**Бишимбаев В.К.** проф., академик (Казахстан)  
**Буктуков Н.С.** проф., академик (Казахстан)  
**Булат А.Ф.** проф., академик (Украина)  
**Ганиев И.Н.** проф., академик (Таджикистан)  
**Грэвис Р.М.** проф. (США)  
**Ергалиев Г.К.** проф., академик (Казахстан)  
**Жуков Н.М.** проф. (Казахстан)  
**Кенжалиев Б.К.** проф. (Казахстан)  
**Кожаметов С.М.** проф., академик (Казахстан)  
**Конторович А.Э.** проф., академик (Россия)  
**Курскеев А.К.** проф., академик (Казахстан)  
**Курчавов А.М.** проф., (Россия)  
**Медеу А.Р.** проф., академик (Казахстан)  
**Мухамеджанов М.А.** проф., чл.-корр. (Казахстан)  
**Нигматова С.А.** проф. (Казахстан)  
**Оздоев С.М.** проф., академик (Казахстан)  
**Постолатий В.** проф., академик (Молдова)  
**Ракишев Б.Р.** проф., академик (Казахстан)  
**Сейтов Н.С.** проф., чл.-корр. (Казахстан)  
**Сейтмуратова Э.Ю.** проф., чл.-корр. (Казахстан)  
**Степанец В.Г.** проф., (Германия)  
**Хамфери Дж.Д.** проф. (США)  
**Штейнер М.** проф. (Германия)

**«Известия НАН РК. Серия геологии и технических наук».**

**ISSN 2518-170X (Online),**

**ISSN 2224-5278 (Print)**

Собственник: Республиканское общественное объединение «Национальная академия наук Республики Казахстан (г. Алматы).

Свидетельство о постановке на учет периодического печатного издания в Комитете информации и архивов Министерства культуры и информации Республики Казахстан №10892-Ж, выданное 30.04.2010 г.

Периодичность: 6 раз в год.

Тираж: 300 экземпляров.

Адрес редакции: 050010, г. Алматы, ул. Шевченко, 28, ком. 219, 220, тел.: 272-13-19, 272-13-18,

<http://www.geolog-technical.kz/index.php/en/>

---

© Национальная академия наук Республики Казахстан, 2020

Адрес редакции: Казахстан, 050010, г. Алматы, ул. Кабанбай батыра, 69а.

Институт геологических наук им. К. И. Сатпаева, комната 334. Тел.: 291-59-38.

Адрес типографии: «NurNaz GRACE», г. Алматы, ул. Рыскулова, 103.

Editor in chief

doctor of Economics, professor, academician of NAS RK

**I. K. Beisembetov**

Deputy editor in chief

**Zholtayev G.Zh.** prof., dr. geol-min. sc.

Editorial board:

**Abakanov T.D.** prof. (Kazakhstan)  
**Abisheva Z.S.** prof., academician (Kazakhstan)  
**Agabekov V.Ye.** academician (Belarus)  
**Aliyev T.** prof., academician (Azerbaijan)  
**Bakirov A.B.** prof., (Kyrgyzstan)  
**Bespayev Kh.A.** prof. (Kazakhstan)  
**Bishimbayev V.K.** prof., academician (Kazakhstan)  
**Buktukov N.S.** prof., academician (Kazakhstan)  
**Bulat A.F.** prof., academician (Ukraine)  
**Ganiyev I.N.** prof., academician (Tadjikistan)  
**Gravis R.M.** prof. (USA)  
**Yergaliev G.K.** prof., academician (Kazakhstan)  
**Zhukov N.M.** prof. (Kazakhstan)  
**Kenzhaliyev B.K.** prof. (Kazakhstan)  
**Kozhakhmetov S.M.** prof., academician (Kazakhstan)  
**Kontorovich A.Ye.** prof., academician (Russia)  
**Kurskeyev A.K.** prof., academician (Kazakhstan)  
**Kurchavov A.M.** prof., (Russia)  
**Medeu A.R.** prof., academician (Kazakhstan)  
**Muhamedzhanov M.A.** prof., corr. member. (Kazakhstan)  
**Nigmatova S.A.** prof. (Kazakhstan)  
**Ozdoyev S.M.** prof., academician (Kazakhstan)  
**Postolatii V.** prof., academician (Moldova)  
**Rakishev B.R.** prof., academician (Kazakhstan)  
**Seitov N.S.** prof., corr. member. (Kazakhstan)  
**Seitmuratova Ye.U.** prof., corr. member. (Kazakhstan)  
**Stepanets V.G.** prof., (Germany)  
**Humphery G.D.** prof. (USA)  
**Steiner M.** prof. (Germany)

**News of the National Academy of Sciences of the Republic of Kazakhstan. Series of geology and technology sciences.**

**ISSN 2518-170X (Online),**

**ISSN 2224-5278 (Print)**

Owner: RPA "National Academy of Sciences of the Republic of Kazakhstan" (Almaty).

The certificate of registration of a periodic printed publication in the Committee of information and archives of the Ministry of culture and information of the Republic of Kazakhstan N 10892-Ж, issued 30.04.2010.

Periodicity: 6 times a year.

Circulation: 300 copies.

Editorial address: 28, Shevchenko str., of. 219, 220, Almaty, 050010, tel. 272-13-19, 272-13-18,

<http://www.geolog-technical.kz/index.php/en/>

---

© National Academy of Sciences of the Republic of Kazakhstan, 2020

Editorial address: Institute of Geological Sciences named after K.I. Satpayev

69a, Kabanbai batyr str., of. 334, Almaty, 050010, Kazakhstan, tel.: 291-59-38.

Address of printing house: «NurNaz GRACE», 103, Ryskulov str, Almaty.

**NEWS**

OF THE NATIONAL ACADEMY OF SCIENCES OF THE REPUBLIC OF KAZAKHSTAN

**SERIES OF GEOLOGY AND TECHNICAL SCIENCES**

ISSN 2224-5278

Volume 2, Number 440 (2020), 6 – 13

<https://doi.org/10.32014/2020.2518-170X.25>

UDC 532.542; 519.688

IRSTI 73.39.81

**I. K. Beysembetov<sup>1</sup>, T. T. Bekibayev<sup>1</sup>, U. K. Zhapbasbayev<sup>1</sup>,  
G. I. Ramazanova<sup>1</sup>, M. Panfilov<sup>2</sup>**

<sup>1</sup>Satbayev University, Almaty, Kazakhstan;

<sup>2</sup>University of Lorraine, Nancy, France.

E-mail: timur\_bekibaev@mail.ru, gaukhar.ri@gmail.com, uzak.zh@mail.ru

**SMARTTRAN SOFTWARE FOR TRANSPORTATION  
OF OIL JSC KAZTRANSOIL**

**Abstract.** Digital technology for monitoring, controlling and optimizing technological practices of oil and oil mixtures pumping through the sections of main pipelines, operating pumping units, preheaters, ground temperature, oil rheological properties and etc. has been created in a result of integration of a SmartTran software with of the Supervisory Control and Data Acquisition (SCADA) and the Automated Metering System (AMS) systems of the JSC “KazTransOil”. The paper describes the main functionalities of the SmartTran software which was developed by the authors.

Thermohydraulic calculations of the sections of the main oil pipelines of JSC “KazTransOil” were carried out and compared with the actual data on the distribution of oil pressure, oil and ground temperature, power consumption of pumping equipment taken from SCADA and AMS.

The accordance of the calculated and actual data shows the applicability of the SmartTran software for the automation of calculations, planning and optimization of the technological modes of oil transportation through the main oil pipelines of JSC “KazTransOil”.

**Key words:** software, integration, main oil pipeline, oil transportation, simulation, optimization.

**Introduction.** Automation of calculation [1-10], planning [11-16] and optimization [17-21] of the technological modes of oil transportation is in high importance in energy saving and energy efficiency issues of the oil and gas sector of economy. In consequence of the integration of SmartTran software, SCADA and AMS information systems of JSC “KazTransOil” has created an intelligent system for automating calculations and optimizing technological modes of oil and oil mixtures pumping in the sections of the main oil pipelines, pump units, preheaters operating, ground temperatures, rheological properties of oils etc.

Based on the historical data of the JSC “KazTransOil” SCADA system the following was carried out: 1) analysis of tags and industrial data by the operational pumping modes; 2) adaptation of head-capacity and energy characteristics of pumping units depending on their operational life; 3) adaptation of the pipelines’ hydraulic resistance along main pipeline sections taking into account the rheological properties of the oil mixtures, changes in pipe roughness due to the asphaltene-resin-paraffin deposits; 4) adaptation of heat transfer coefficients between the “hot” oil and the ground, depending on changes in the ground thermal conductivity along main pipeline sections; 5) adaptation of the preheaters’ characteristics depending on efficiency, pressure drop, etc.

According to the AMS and SCADA data the consumed power of pumping units, the cost of operating pumps and preheaters, the distribution of pressure and temperature of oil and oil mixtures in main pipelines sections, the change in ground temperature along the route can be found in real-time mode.

The SmartTran software has the following performance capabilities:

1. Heat-hydraulic calculations of stationary modes of high viscous and high pour point oil transportation for the safe operation of the main pipelines (taking into account associated pumping in and pumping out, pipe defects, loops and branches, pressure regulator and input of additives that reduce the hydraulic resistance of the pipeline, the pour point temperature of oil);
2. Heat-hydraulic calculations of non-stationary cooling and restart modes after short-term stops for the safe operation of the main oil pipelines;
3. Heat-hydraulic calculations of serial transfer of different varieties of high viscous and high pour point oils mixtures through the sections of the main pipelines;
4. Heat-hydraulic calculations of energy saving modes of main pumping units with detachable rotors and variable frequency drive for stationary operation regimes;
5. Determination of the optimum heating temperature of oil mixtures and energy-saving modes of preheaters for stationary “hot” operation modes;
6. Selection of pumping equipment with detachable rotors and variable frequency drive for forecasting the maximum capacity of the pipeline in terms of the safe pumping conditions;
7. Adaptation of real characteristics of pumping equipment of the pumping stations (PS) according to the SCADA historical data;
8. Adaptation of the hydraulic characteristics of the pipe due to changes in wall roughness and heat transfer coefficient depending on the ground thermal conductivity of the main oil pipelines sections.
9. Designing of new sites, the addition of pumping equipment at PS and input of rheological properties of oil mixtures.

The mechanisms for obtaining actual data on operation modes of oil pipeline, storing and uploading them to the user interface for analysis and processing have been developed in the SmartTran software. Figure 1 shows the interaction diagram of the SmartTran software with the SCADA and AMS. Data from the sensors (pressure, temperature, flow rate, network frequency measurements) are sent to the SCADA server from all sections of the JSC “KazTransOil” main pipelines. The special OPC client of the SmartTran integration server receives sensor data from the SCADA server via the WinCC system using the OPC protocol with a frequency of 30 minutes. The OPC client exports the actual data to the historical database in MySQL format of the SmartTran DB server. The use of an intermediate server (the SmartTran integration server) is dictated by the JSC “KazTransOil” security policy (figure 1).

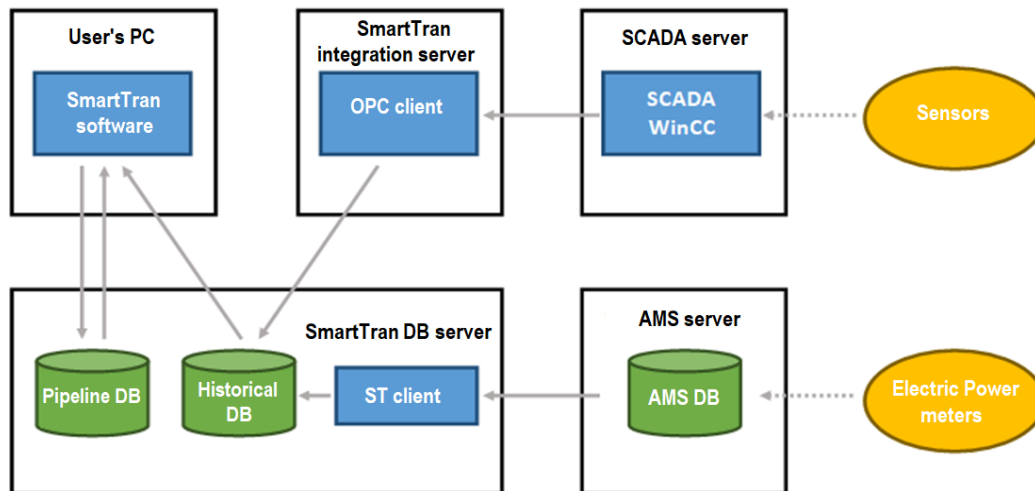

Figure 1 – The SmartTran interaction diagram with SCADA and AMS systems of JSC “KazTransOil”

The electric energy data from various devices of JSC “KazTransOil” are transferred to a separate AMS server and stored in a MySQL-format DB. The special client application (ST-client) was developed on the SmartTran DB server, which receives new data of the active power consumption of JSC “KazTransOil” pumping units from the AMS DB and exports them to the historical data DB in the required format every 30 minutes.

In that way the actual data of the technological pumping modes parameters are stored as historical data in the SmartTran software DB.

The SmartTran applications only interact with the SmartTran DB server on users' computers. The users download data on the oil pipelines sections from the single pipeline DB, which provides data actuality. Individual users can also make changes to the pipeline DB (oil library, pump library, pipe parameters, etc.) if they have rights to edit various parameters of pipelines. In the same DB user-defined calculations are stored, for the analysis of which the historical data are used. The SmartTran software uses the historical data to adjust the parameters of pumps, pipes and grounds, which also lead to changes in the pipelines DB.

**Analysis and discussion of the calculated data.** The calculations results of technological pumping regimes of oil and oil mixtures along some oil pipeline routes of JSC “KazTransOil” are given below using data from the SCADA, AMS systems.

Figure 2 presents the comparison results of the calculated data (curves) with the actual SCADA values (points) of the Karazhanbas-Aktau pipeline section. The upper plot of the figure 2 shows the distribution of the hydraulic slope, the middle one shows the oil pressure distribution, and the lower plot presents the oil temperature distribution. The calculation results of the power consumption of pumping units and the pumping cost according to AMS are presented in a tabulated form (figure 2).

High-viscosity oil is pumped at the Karazhanbas-Aktau pipeline section. Hydraulic slope, oil pressure and temperature distributions show good agreement with the calculated lines with the actual SCADA data of JSC “KazTransOil” (figure 2).

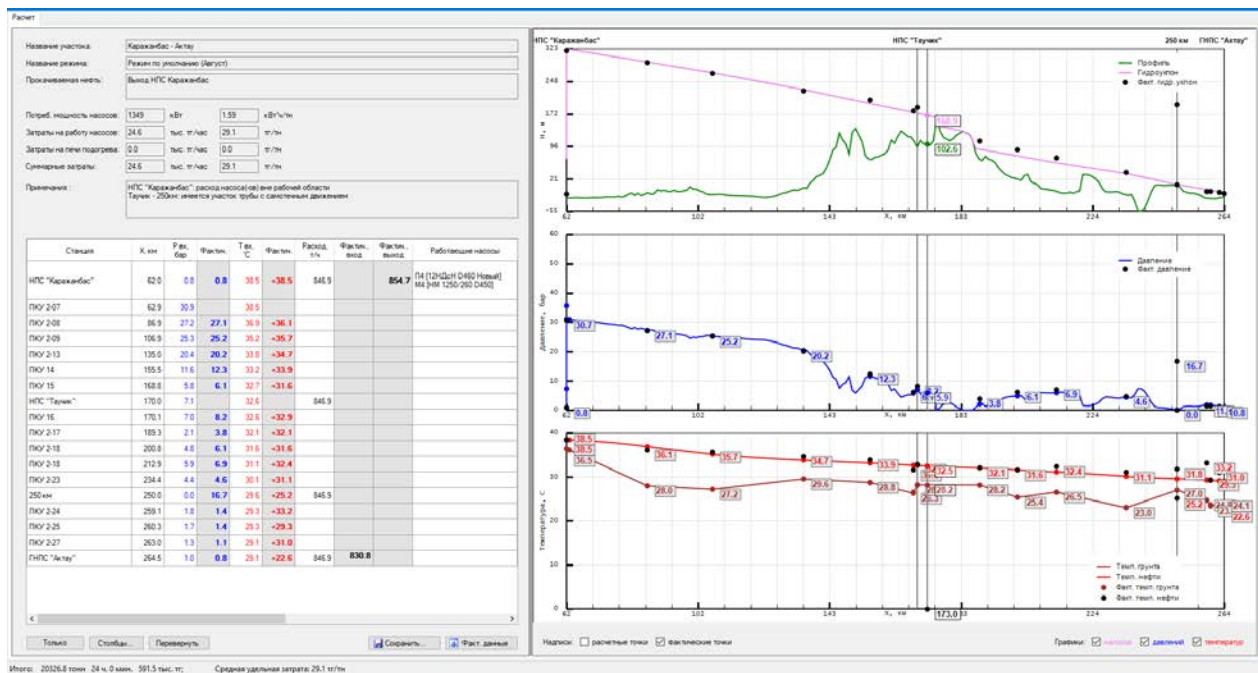

Figure 2 – Comparison of calculated (lines) data with experimental points of the Karazhanbas-Aktau section

Figure 3 presents the comparison results of the Aktau - Zhetybai pipeline section. The graphical data shows the hydraulic slope distribution (upper plot), oil pressure distribution (middle plot), and oil and ground temperature distribution (lower plot). In the left side of figure 3, the calculations of the power consumption of the pumps and the oil pumping cost according to the AMS data are shown in the table form. Comparison of hydraulic slope, pressure and temperature distributions shows good agreement between calculated data and the actual SCADA values.

Figure 4 shows the results of comparing the calculated data of the Kasymov–Bolshoi Chagan pipeline section with the SCADA data.

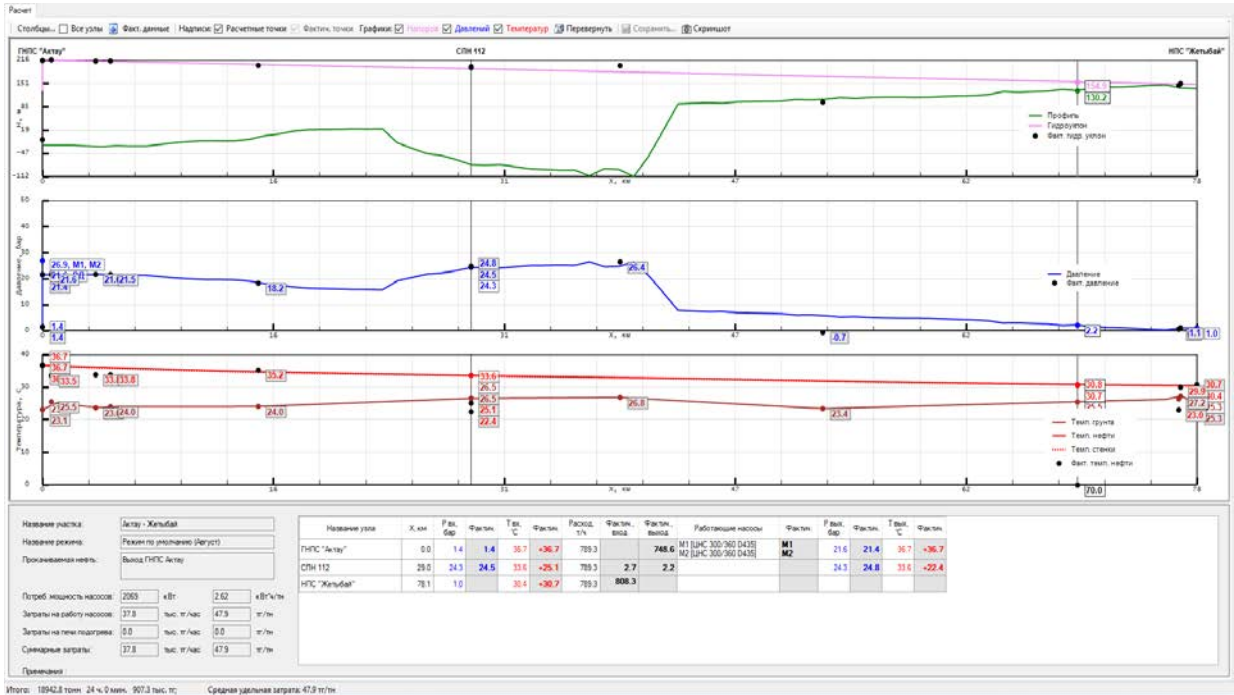

Figure 3 – Comparison of calculated (lines) data with experimental points of the Aktau - Zhetybai section

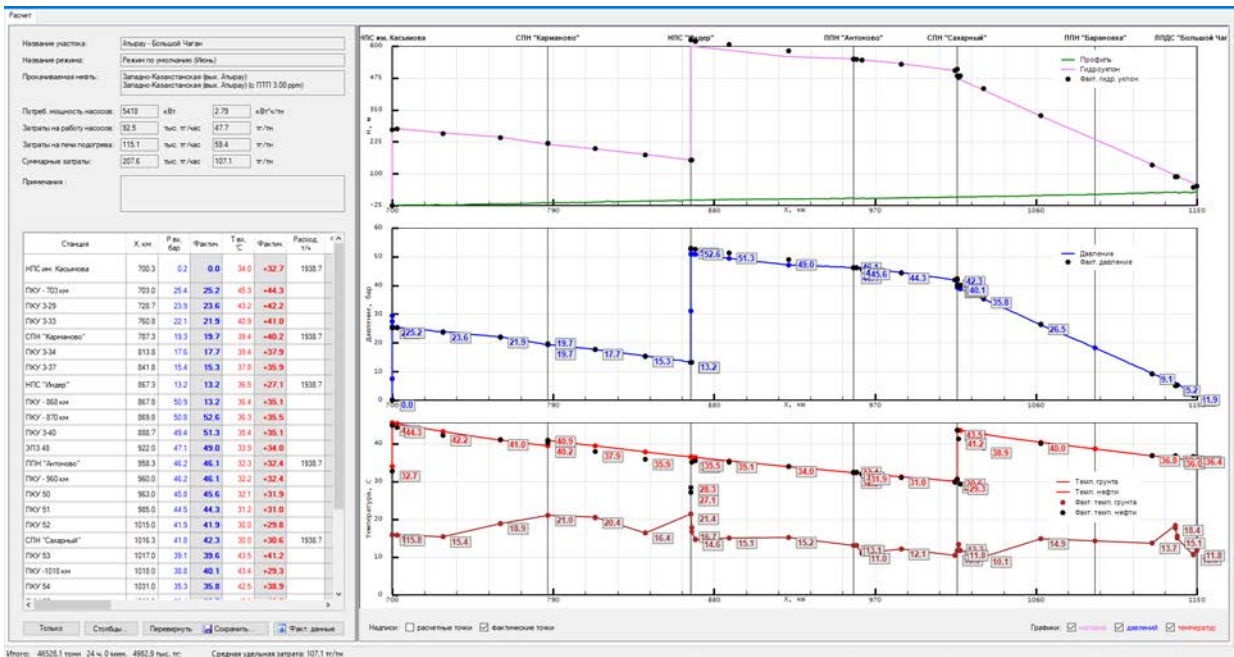

Figure 4 – Comparison of calculated (lines) data with experimental points of the Kasymov - Bolshoi Chagan section

At this pipeline section there is a “hot pumping” of high pour point oil mixtures with associated heating at the T. Kasymova and the Sakharny stations. In addition, an anti-turbulent additive is introduced at the Sakharny station to reduce the hydraulic resistance of the turbulent flow, since at this point the pipeline diameter changes from 1000 to 700 mm and the average flow velocity is almost doubled. Therefore, at high oil flow rates, for example, 1938.7 t / h (figure 4), the anti-turbulent additive is used to reduce the pipeline pressure and for the pumping safety.

The curves of hydraulic slope, pressure and temperature distribution show good agreement with the SCADA actual data (figure 4). Here are also presented the calculations of the energy consumed by pumps and preheaters for pumping and heating oil mixtures.

Figure 5 presents the calculated results of the technological modes of oil transportation along the following pipeline sections: Dzhumagaliyev – Atasu.

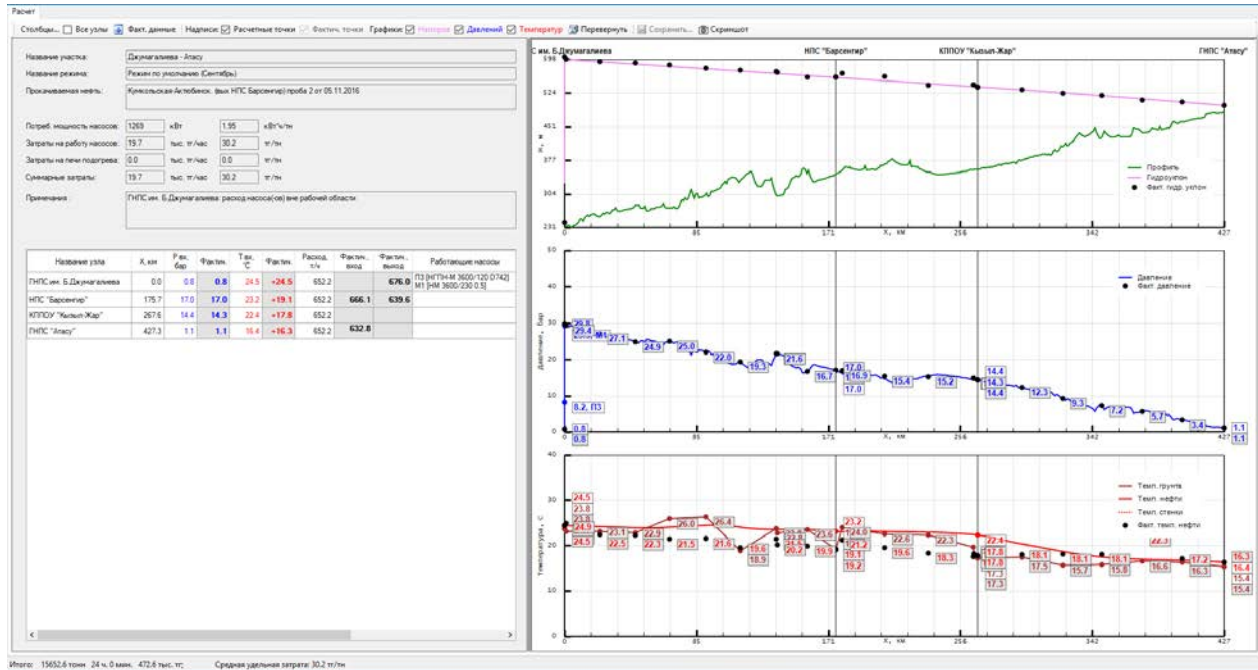

Figure 5 – Comparison of calculated (lines) data with experimental points of the Dzhumagaliyev – Atasu section

In all case, the comparison of the calculated curves obtained by the SmartTran software with the actual SCADA values (figure 5) shows good agreement.

In this way, the comparison of the calculated curves with the actual data confirm the functional capabilities of the SmartTran software for modeling, planning and optimizing the oil transportation of through the oil pipeline routes of JSC “KazTransOil”.

**Conclusion.** 1. The intelligent system for automating calculations, planning and optimizing the technological practices of oil and oil mixtures transportation through the oil pipeline routes of JSC “KazTransOil” has been created by the authors through the integration of SmartTran software with the SCADA and AMS systems of JSC “KazTransOil”.

2. The calculation results are in good agreement with the actual data of the SCADA system. SmartTran software together with SCADA and AMS systems is an effective tool for safe operation of pipelines and calculation of economic factors for oil and oil mixtures pumping through the JCS “KazTransOil” main oil pipelines.

**Acknowledgements.** This work has been supported by the project #AP05130503 “Management of energy-efficient modes of oil transportation through main oil pipelines using the SCADA system”, funded by the Science Committee of the Ministry of Education and Science of the Republic of Kazakhstan.

Е. Қ. Бейсембетов<sup>1</sup>, Т. Т. Бекібаев<sup>1</sup>, Ұ. Қ. Жапбасбаев<sup>1</sup>, Г. И. Рамазанова<sup>1</sup>, М. Панфилов<sup>2</sup>,

<sup>1</sup>Satbayev University, Алматы, Қазақстан;

<sup>2</sup>Лотарингия университеті, Нанси, Франция

### «ҚАЗТРАНСОЙЛ» АҚ МҰНАЙЫН ТАСЫМАЛДАУ БОЙЫНША SMARTTRAN БАҒДАРЛАМАЛЫҚ ЖАСАҚТАМАСЫ

**Аннотация.** SmartTran бағдарламалық жасақтамасын «ҚазТрансОйл» АҚ-ның SCADA және АСКУЭ ақпараттық жүйелерімен интеграциялау нәтижесінде магистральды құбырлармен мұнай және мұнай қоспаларын айдаудың технологиялық режимдерін бақылау, басқару және оңтайландыруға арналған сандық технологиясы жасалды.

SmartTran бағдарламалық жасақтамасында «ҚазТрансОйл» АҚ-ның мұнай құбырларының, сорғы қондырғыларының, жылыту пештерінің, топырақ параметрлері мен мұнай қоспаларының сипаттамалары бойынша дерекқоры бар.

Бағдарлама әр түрлі конфигурациядағы мұнай құбырларының жаңа учаскелерін жобалауға, модельдеуге, сорғы жабдығы және пештердің параметрлері мен мұнай қоспаларының реологиялық қасиеттерін дерекқорға енгізуге немесе оны мәліметтермен жаңартуға мүмкіндік береді.

SmartTran бағдарламалық жасақтамасы тұтқырлығы жоғары және жоғары температурада қататын мұнай қоспаларын айдаудың стационарлық және стационарлық емес режимдерін жылу-гидравликалық есептеуге мүмкіндік береді. Есептеу барысында құбырға жол бойы қосымша мұнай айдау мен шығаруды, қосымша құбырлар мен тармақтарды, құбырлардың ақауларын, қысым реттегіштерін, депрессорлық және анти-турбуленттік қоспаларды енгізуді ескеруге болады.

Бағдарламада келесі функционалдық мүмкіндіктер бар: сорғының қосылуының оңтайлы варианттарын іріктеу арқылы, сонымен қатар ауыспалы жиілікті жетектерді қолданумен энергия үнемдеу режимдерін анықтау; «ыстық» айдау кезінде мұнай қоспаларының оңтайлы қыздыру температурасын анықтау; қауіпсіз айдау жағдайларын ескере отырып, құбырдың максималды өнімділігін болжау; энергияны ең аз тұтынатын ауыспалы режимді қолдана отырып ай сайынғы айдау көлеміне арналған оңтайлы режимді анықтау; SCADA жүйесінің тарихи мәліметтеріне сәйкес сорғы жабдықтарының нақты параметрлерін бейімдеу; мұнай құбырларының учаскелеріндегі топырақтың жылу өткізгіштік қабілетіне байланысты құбырлардың гидравликалық сипаттамаларын және жылу беру коэффициентін бейімдеу.

SCADA және АСКУЭ жүйесінің тарихи мәліметтерін өңдеу нәтижесінде мұнай айдаудың технологиялық режимдері бойынша өндірістік деректерге талдау жасалды; сорғы агрегаттарының сипаттамалары олардың жұмыс ресурстарына қарай бейімделді; құбыр учаскелерінің гидравликалық сипаттамалары бейімделді, магистральды мұнай құбырларының учаскелеріндегі мұнай мен топырақ арасындағы жылу беру коэффициенті және жылыту пештерінің сипаттамалары бейімделді.

SmartTran бағдарламасының модульдерін пайдалана отырып «ҚазТрансОйл» АҚ «Қаражамбас - Ақтау», «Ақтау - Жетібай», «Қасымов – Үлкен Шаған» и «Жұмағалиев - Атасу» атты мұнай құбырларының учаскелеріне жылу гидравликалық есептеулер жүргізілді. Есептеу нәтижелері SCADA және АСКУЭ жүйелерінің мұнайдың гидравликалық ауытқуы, қысымы, температурасы, топырақ температурасы, сорғы қондырғыларының энергияны тұтынуы бойынша нақты мәліметтерімен салыстырылды.

Есептеу нәтижелері мен нақты деректердің бір-бірімен сәйкестігі SmartTran бағдарламалық жасақтамасының «ҚазТрансОйл» АҚ магистральдық мұнай құбырларымен мұнай және мұнай қоспаларын тасымалдаудың технологиялық режимдерін есептеуді автоматтандыру, жоспарлау және оңтайландыру мақсатында қолдануға жарамды екенін көрсетеді.

**Түйін сөздер:** бағдарламалық жасақтама, интеграция, магистральды мұнай құбыры, мұнай тасымалдау, модельдеу, оңтайландыру.

**И. К. Бейсембетов<sup>1</sup>, Т. Т. Бекибаев<sup>1</sup>, У. К. Жапбасбаев<sup>1</sup>, Г. И. Рамазанова<sup>1</sup>, М. Панфилов<sup>2</sup>**

<sup>1</sup>Satbayev University, Алматы, Казахстан;

<sup>2</sup>Университет Лотарингии, Нанси, Франция

### **ПРОГРАММНОЕ ОБЕСПЕЧЕНИЕ SMARTTRAN ПО ТРАНСПОРТИРОВКЕ НЕФТИ АО «КАЗТРАНСОЙЛ»**

**Аннотация.** В результате интеграции программного обеспечения SmartTran с информационными системами SCADA и АСКУЭ АО «КазТрансОйл» разработана цифровая технология для мониторинга, управления и оптимизации технологических режимов перекачки нефти и нефтяных смесей на участках магистральных нефтепроводов.

Программное обеспечение «SmartTran» имеет базу данных по характеристикам участков нефтепроводов, насосным агрегатам, печам подогрева, параметрам грунтов и нефтяным смесям АО «КазТрансОйл».

Программа позволяет проектировать и моделировать новые участки нефтепроводов различной конфигурации, дополнять и обновлять базу данных параметрами насосного оборудования, печей подогрева и реологическими свойствами нефти и нефтяных смесей.

Программное обеспечение SmartTran позволяет проводить тепло-гидравлические расчеты стационарных и нестационарных режимов перекачки высоковязких и высокозастывающих нефтесмесей с учетом попутных подкачек и откачек, лупингов и ответвлений, дефектов трубы, регулятора давления и ввода депрессорных и противотурбулентных присадок.

Программа имеет следующие функциональные возможности: определение энергосберегающих режимов с подбором оптимальных вариантов соединения насосов, а также с использованием частотно-регулируемых приводов; определение оптимальной температуры подогрева нефтесмесей при «горячей» перекачке; прогнозирование максимальной производительности нефтепровода с учетом условий безопасной перекачки; определение оптимальных режимов перекачки при заданном месячном объеме перекачки с использованием переменного режима с наименьшим удельным энергопотреблением; адаптация фактических параметров насосного оборудования по историческим данным системы SCADA; адаптация гидравлических характеристик труб и коэффициента теплопередачи в зависимости от теплопроводности грунта на участках нефтепроводов.

В результате обработки исторических данных SCADA и АСКУЭ проведены анализ производственных данных по технологическим режимам перекачки; адаптация характеристик насосных агрегатов в зависимости от ресурса их работы; адаптация гидравлических характеристик участков трубопроводов, адаптация коэффициента теплопередачи между нефтью и грунтом на участках магистральных нефтепроводов, адаптация характеристик печей подогрева.

С использованием модулей программного обеспечения SmartTran были проведены тепло-гидравлические расчеты на некоторых участках нефтепроводов АО «КазТрансОйл»: «Каражанбас - Актау», «Актау - Жетыбай», «Касымова – Большой Чаган» и «Джумагалиева - Атасу». Результаты расчетов для каждого участка нефтепроводов были сопоставлены с фактическими данными SCADA и АСКУЭ по распределению гидравлического уклона, давления, температуры нефти и грунта, потребляемой мощности насосного оборудования.

Согласие расчетных и фактических данных показывает применимость разработанной цифровой технологии для автоматизации тепло-гидравлических расчетов, планирования и оптимизации технологических режимов транспортировки нефти и нефтесмесей по магистральным нефтепроводам АО «КазТрансОйл».

**Ключевые слова:** программное обеспечение, интеграция, магистральный нефтепровод, транспортировка нефти, моделирование, оптимизация.

#### **Information about the authors:**

Bissembetov Iskander Kalybekovich, Satpayev University, Almaty, Kazakhstan, Rector, Academician of the National Academy of Sciences of the Republic of Kazakhstan, Dr. Econ. Sci.; mihar1999@mail.ru; <https://orcid.org/0000-0002-0958-639X>

Bekibayev Timur Talgatovich, Satpayev University, Almaty, Kazakhstan, Head of Section, Master of Engineering and Technology; timur\_bekibaev@mail.ru; <https://orcid.org/0000-0001-7030-0015>

Zhabbasbayev Uzak Kaibekovich, Satpayev University, Almaty, Kazakhstan, Head of Research Laboratory, Dr. Tech. Sci., Prof.; uzak.zh@mail.ru; <https://orcid.org/0000-0001-5973-5149>

Ramazanov Gaukhar Izbasarovna, Satpayev University, Almaty, Kazakhstan, Senior Researcher, Cand. Phys. and Math. Sci.; gaukhar.ri@gmail.com; <https://orcid.org/0000-0002-8689-9293>

Panfilov Mikhail, Institute of Mathematics Elie Cartan, University of Lorraine, Nancy, France, Dr. Sci., Member of National Scientific Committee of France; michel.panfilov@univ-lorraine.fr; <https://orcid.org/0000-0002-0691-911X>

#### **REFERENCES**

[1] Wojcik W., Alimzhanova Zh.M., Velyamov T.T., Akhmetova A.M. (2019) About one model of pumping oil mixture of different viscosities through a single pipeline in an unsteady thermal field, *News of the National academy of sciences of the Republic of the Kazakhstan. Series of geology and technical sciences.* 5 (437): 207-214. DOI: 10.32014/2019.2518-170X.144 (in Eng.).

[2] Gumerov A.G., Shutov A.A., Shtukaturov K.Yu. (2004) The software package NIPAL: simulation of operating conditions for non-isothermal pipeline transporting rheologically problematic crudes, *Oil Industry [Neftyanoe Khozyaystvo]* 6: 106-109 (in Russ.).

[3] Yesaulov A.O., Teksheva I.V. (2010) Modeling of pipeline management systems, *Oil Pipeline transportation [Truboprovodnyy transport nefiti]* 8: 63-65 (in Russ.).

[4] Bogdanov R.M. (2014) Software system for modeling the work of oil pipelines, *Oil and gas business: electronic scientific journal [Neftegazovoye delo]* 1, <http://www.ogbus.ru> (in Russ.).

- [5] Tmur A.B. (2014) Methods of identification of the technological process of oil pipeline transportation: The dissertation of Cand. of Tech. Sciences: 05.13.06. M. 115 p. (in Russ.).
- [6] Gafarov R.R. (2009) Automated system for determining the optimal mode of operation of the main oil pipeline section: The dissertation of Cand. of Tech. Sciences: 05.13.06. Ufa. 137 p. (in Russ.).
- [7] Clarke S.L. (2002) Centralized control improves operating efficiency, *Oil & Gas Journal*, 100.7: 50-55 (in Eng.).
- [8] Emara-Shabaik H.E., Khulief Y.A., Hussaini I. (2004) Simulation of transient flow in pipelines for computer-based operations monitoring, *Int. J. Num. Meth. Fluids*, 44: 257–275. DOI: 10.1002/fld.636 (in Eng.).
- [9] Kawashima K., Shintaro I., Tatsuya F., Kagawa T. (2006) Monitoring of unsteady flow in a pipeline with integrating measurement and simulation, *Systems Modeling and Simulation*, 42: 837-843. DOI: 10.1007/978-4-431-49022-7\_7 (in Eng.).
- [10] Matko D., Geiger G., Gregoritz W. (2000) Pipeline simulation techniques, *Mathematics and Computers in Simulation*, 52: 211-230 DOI: 10.1016/S0378-4754(00)00152-X (in Eng.).
- [11] Feizlmayer A.H., Weil F. (2000) Economic analysis of crude oil pipelines, *Oil & Gas J.*, 98.47: 70-77 (in Eng.).
- [12] Fedorov P.V. (2011) Improving the methods of technological regimes and monitoring the process of oil pipelines transportation: Abstract of thesis of Cand. Tech. Sciences: 25.00.19. Ukhta. 25 p. (in Russ.).
- [13] Kutukov S.E. (2002) Information and analytical systems of main pipelines. SIP RIA, Moscow. 324 p. ISBN: 5-89354-150-2 (in Russ.).
- [14] Dai Zh. (2019) Analysis on influencing factors of buried hot oil pipeline, *Case Studies in Thermal Engineering*, 16, 100558. DOI: 10.1016/j.csite.2019.100558
- [15] Silva A.C., Fernandes J.F.R., Ohishi T. et al. (1999) Intelligent Control of Oil Transportation in a Pipeline Network by Genetic Algorithm and Simplex Method, *Proceedings of XV COBEM*. P. 20-25 (in Eng.).
- [16] Herran A., de la Cruz J.M., de Andres B. (2010) A mathematical model for planning transportation of multiple petroleum products in a multi-pipeline system, *Computers and Chemical Engineering*, 34: 401–413. DOI: 10.1016/j.compchemeng.2009.11.014 (in Eng.).
- [17] Zhang Y., Wang B., Huang X. (2020) Online Optimization of Heated-Oil Pipeline Operation Based on Neural Network System Identification, *Journal of Pipeline Systems Engineering and Practice*, 11 (1). DOI: 10.1061/(ASCE)PS.1949-1204.0000421 (in Eng.).
- [18] Tumansky A.P. (2005) Optimization of pumping modes through main pipelines with pumping stations equipped with a frequency-controlled drive, *Transport and storage of oil products* [Transport i khraneniye nefteproduktov] 8: 11-14 (in Russ.).
- [19] Zhabbasbayev U.K., Makhmotov E.S., Bekibayev T.T., Ramazanova G.I. (2018) Calculations of energy-saving modes for oil mixtures batching in trunk pipeline section, *Nauka i tehnologii truboprovodnogo transporta nefi i nefteproduktov-science & Technologies-oil and oil products pipeline transportation*, 8: 326-336. DOI: 10.28999/2541-9595-2018-8-3-326-336 (in Eng.).
- [20] Wang Y., Liu Y., Zhao J., Wei L.X. (2013) Energy Consumption Analysis and Comprehensive Optimization in Oil Pipeline System, *Advanced Materials Research*, 648: 251-254. DOI: 10.4028/www.scientific.net/AMR.648.251 (in Eng.).
- [21] Liu E.B., Li C.J., Yang L.T., Liu S., Wu M.C., Wang D. (2015) Research on the optimal energy consumption of oil pipeline, *Journal of Environmental Biology*, 36: 703-711 (in Eng.).

**NEWS**

OF THE NATIONAL ACADEMY OF SCIENCES OF THE REPUBLIC OF KAZAKHSTAN

**SERIES OF GEOLOGY AND TECHNICAL SCIENCES**

ISSN 2224-5278

Volume 2, Number 440 (2020), 14 – 20

<https://doi.org/10.32014/2020.2518-170X.26>

UDC 550.341; 550.42 (575)

**A. U. Abdullayev<sup>1</sup>, Sh. S. Yusupov<sup>2</sup>**

<sup>1</sup>Institute of Seismology CS MES RK, Almaty, Kazakhstan;

<sup>2</sup>Institute of Seismology named after Mavlyanov,  
Academy of Sciences of the Republic of Uzbekistan, Tashkent, Uzbekistan.

E-mail: u.abdullaev@mail.ru, shuhrat-1951@mail.ru

**OPTIMIZATION OF QUANTITATIVE INDICATORS  
OF COMPLEX SEISMO-HYDROGEOCHEMICAL MONITORING  
WITH THE PURPOSE OF FORECASTING STRONG EARTHQUAKES**

**Abstract.** The quantitative indicators of seismic hydrogeochemical monitoring (SHCM) conducted on the geodynamic forecasting sites of Asia are considered. It is noted that continuous multi-parameter observation is implemented on the basis of simultaneous measurement from several to tens of parameters of groundwater. The most common complex includes about 10-15 parameters (F, Cl, HCO<sub>3</sub>, CO<sub>3</sub>, SO<sub>4</sub>, H<sub>4</sub>SiO<sub>4</sub>, Rn, He, H<sub>2</sub>, CO<sub>2</sub>, Ph, Eh, Q<sub>hole</sub>, H<sub>level</sub>, T<sub>water</sub>.) monitoring over many decades it has been established that the informativeness of the obtained forecast data does not depend on the number of measured parameters, but is determined by the cumulative effect of sensitive components for a given water product observed. Therefore, the optimization of the list of observable parameters for the entire landfill as a whole should be differentiated taking into account the features of each water point. This allows you to dramatically reduce the number of parameters of observation and get rid of the "ballast" indicators.

**Key words:** seismic hydrogeochemistry, monitoring, earthquakes, forecast, hydrogeochemical anomalies, informative.

After Tashkent (1966), Dagestan (1970) and especially, the Haichen catastrophic earthquake (1975), predicted by Chinese seismology, intensive multidisciplinary seismic prognostic studies began all over the world. Along with seismological and geophysical methods, large-scale geochemical and hydrogeological observations were deployed in order to search for precursors and forecast strong earthquakes [1,3,4,5,8,9]. It is necessary to emphasize that earthquakes of various energies constantly occur on the Earth as a continuous chain of events; meanwhile, the forecast can be made only for those rare events that are of a destructive nature. The need to forecast such earthquakes for different areas is determined differently, based on the level of their seismic activity [2,3].

Ideology of geochemical and hydrogeological monitoring. The forecast paradigm was based on the well-known models of earthquake preparation and on this basic avalanche-unstable crack formation (AUC) and diffusion-dilatant development of the source (DD). It was assumed that in the focal zone of the earthquake there occurs a jump-increasing accumulation of elastic energy, which after a critical state passes to a mechanical discontinuity of the continuity of the medium with the generation of seismic waves, i.e. to an earthquake. It is assumed that in this process a wide class of precursors of various amplitudes should arise in deformation, geophysical, geochemical, and hydrogeological fields. The occurrence of hydrogeochemical anomalies was associated with the arrival of new fluids from the focal zone or the displacement of different chemical composition in the preparation zone of the earthquake [1,2,4-11]. The forecast paradigm consisted in solving the inverse problem: by the signs - the precursors and by the time of their development in the controlled area to establish the probable time and place of occurrence of the expected event, and by the intensity of anomalies - their probable energy. This scientific concept has determined the main way to achieve the goal - the creation of continuous mode multidisciplinary observations at special test sites on the principle: the wider the area and the larger the set

of observation parameters, the more reliable the detection of precursors. With sufficiently strong financial support from the states, especially the USSR, China, Japan, Italy, Greece, etc., in the 1980s – 1990s, large-scale monitoring observations were conducted to predict earthquakes on so-called geodynamic or prognostic sites. For example, in the USSR such landfills unfolded in all seismic areas of the Caucasus, Central Asia, Kazakhstan, Baikal and the Kuril-Kamchatka region, where they began to observe more than a hundred wells and water points. The most powerful development of hydrogeochemical (HGC) and hydrogeodynamic (HGD) observations unfolded in the People's Republic of China on the basis of more than 1,000 wells and special wells with the extensive development of a network of "people's-observers-enthusiasts." At various landfills, the list of observed parameters with discreteness from continuous hourly to daily was different, but the overall large set of indicators, in general, in the world amounted to more than 40 items [1,13-15] (table 1-9). It should be noted that the largest developed program of field observations with a large set of measured parameters was organized in Kazakhstan [1,3,4,5,8,9] (tables 1 and 2). All observation grounds in the USSR were constructed according to special guidelines [12].

The main results of field observations and experimental studies.

For each water point, first of all, long-term background values of the parameters were obtained and their anomalous fluctuations were recorded on the eve of many strong earthquakes. They were noted at various distances from the epicenters (tens and hundreds of kilometers). Such anomalies consisted of intermittent alternating temporal changes of various parameters having various forms, which can be reduced to the following four morphogenetic groups: coves, semi-bottoms, "jumps-pulsations" and spontaneous bursts. In amplitude of changes, they usually exceed the background values of the parameters by 20-50% to 100%, and sometimes they have significant one-time variations. The most important features of these anomalies are: 1) the instability of their development over time and in the area (flicker); 2) their rapid return to the initial background value after earthquake relaxation; 3) "long-range", manifested in tens and hundreds of km from the earthquake source, it turned out that many anomalies are not associated with specific earthquakes and were caused by the impact on the relevant parameters of external atmospheric and cosmophysical factors and man-made interference [1]. Anomalies caused by the nature of periodic rhythmic phenomena. These factors created a lot of noise and false alarms, comparable in magnitude and time with the anomalies that occur during the preparation of earthquakes.

Very often, HGC and HGD anomalies occurred in the non-focal zone of earthquakes at significant distances, reflecting the stress-strain state (SSS) in the surface part of the earth's crust, where water observation points are located. The observed anomalies were a consequence of the development of deformation processes. Thus, we can conclude that the fluid anomalies of the expected earthquake are the result of an imbalance in the local equilibrium hydrogeochemical water-rock-gas systems with the generation of dissipative temporal anomalies as a response of these systems to external forces in full compliance with Le Chatelier's law [1]. From this it becomes obvious that strong earthquakes are being prepared on a fairly large area as a result of the restructuring of the geoblocks' SSS and their repacking [1,2,4,6,9-11]. Detailed studies of the time course, parameters of geochemical, hydrogeochemical and hydrogeodynamic fields on the eve of earthquakes showed that anomalies are not only statistically significant changes in the course of parameters of different nature and changes in the frequency-spectral characteristics of the series itself in those time intervals that reflect the non-linear development of the instability process itself with the formation of a violation in the correlation of regular components of time series such as, for example, with  $R_{atm}$ ,  $T_{water}$ , TF (tidal forces). It is established that the high-frequency component of the geochemical, hydrogeochemical and hydrogeodynamic fields carries the greatest information in terms of recognizing geodynamic instability.

At the beginning of seismic hydrogeochemical studies (70-90s of the 20th century) in large research laboratories of GEOKHI, IGEM and IPD of the Academy of Sciences of the USSR; SIMS and VSEGINGEO MG of the USSR, as well as the Institute of Seismology, Academy of Sciences of Uzb. SSR, IS AN Kaz. SSR, Institute of Physics, Academy of Sciences Kirg. USSR and others, where mass spectrometers and other devices were installed, and it was revealed that on the eve of the realization of strong earthquakes, significant precursor changes in the isotopic ratios of many elements take place: hydrogen, oxygen, carbon, uranium, helium, argon ( $^3\text{He} / ^4\text{He}$ ,  $^{13}\text{C} / ^{12}\text{C}$ ,  $^{36}\text{Ar} / ^{40}\text{Ar}$ ,  $^{234}\text{U} / ^{238}\text{U}$ ). However, due to the high complexity and laboriousness of these analyzes, their high costs and the impossibility of performing analyzes in a continuous mode, such parameters have not been developed in the number of indicative monitoring indicators of earthquakes.

Table 1 – The list of measured parameters of the complex hydrogeochemical monitoring and the equipment used at the Almaty prognostic site for the purpose of predicting strong earthquakes (Kazakhstan)

Main indicators	№	Options	Method of Definition	
			Manual measurements	Automatic measurements
Dynamic performance	1	H <sub>level</sub>	Visual (by line), by level gauge	Ultrasound method
	2	Q	Volumetric (using a measuring tank and a stopwatch)	volumetric
	3	P <sub>hole</sub>	Manometer	Manometer
Physical and chemical indicators	4	Ph	Potentiometric method (ionomers)	Potentiometric method
	5	Eh		
	6	P	Water conductivity	Portable tester
	7	T <sub>water</sub>	visual	Thermometer
	8	Rn	Emanational	Emanational device, method ("Radon")
	9	Gf	Volumetric method	
The main ion-salt composition of thermal waters	10	Ca <sup>2+</sup>	Volumetric visual method (titrimetric)	
	11	Mg <sup>2+</sup>		
	12	Cl		
	13	H <sub>4</sub> SiO <sub>4</sub>	Colorimetric method ("KFK-2", "KFK-3")	
	14	SO <sub>4</sub> <sup>2-</sup>		
15	F			
	16	K <sup>+</sup>	Flame Photometric Method ("PFP -7")	
	17	Na <sup>+</sup>		
	18	HCO <sub>3</sub> <sup>-</sup>	Volumetric titromereous method ("BAT" -block aut. Titration)	
	19	CO <sub>3</sub> <sup>2-</sup>		
	20	OH <sup>-</sup>		
Gas composition	21	He <sub>cn</sub>	Chromatographic Spontaneous gas method (chromatograph "COLOR - 800")	
	22	He <sub>p</sub>		
	23	H <sub>2</sub>		
	24	CH <sub>4</sub>		
	25	CO <sub>2</sub>		
	26	O <sub>2</sub>		
	27	N <sub>2</sub>		
Geophysical indicator of external fields	28	(EHII)	Natural neutron flux (NNF). (detector of slow neutrons "PKC-01H-COJO")	
Related Parameters	29	P <sub>atm</sub> <sup>1</sup> atm	Automatic recording of air temperature and atmospheric pressure ("Barometers and thermometers")	
	30	T <sub>Bo3</sub>		

Table 2 – The abbreviated list of hydrogeochemical parameters adopted for seismic forecast observations in the MG system of the Kazakh SSR in 1985-1988 (Kazakhstan)

Defined parameters	Rn, F, Cl, Li, Sz, He, H <sub>2</sub> , CH <sub>4</sub>	Quantity
		8

Table 3 – Bishkek polygon (Kyrgyzstan)

Dynamic and physical parameters	Gases	Chemical composition of groundwater	Quantity
Ph, Eh, Q <sub>CKB</sub> , H <sub>вп</sub> , T <sub>воды</sub>	CO <sub>2</sub> , Gf	F, Cl, HCO <sub>3</sub> <sup>-</sup> , SO <sub>4</sub> <sup>2-</sup> , Ca, Mg <sup>2+</sup>	13

Table 4 – Tashkent polygon (Uzbekistan)

Dynamic and physical parameters	Gases	Chemical composition of groundwater	Quantity
Ph, Eh, Q <sub>CKB</sub> , H <sub>уп</sub> , T <sub>воды</sub>	CO <sub>2</sub> , H <sub>2</sub> , CH <sub>4</sub> , Rn, He, Al	Br, B, F, HCO <sub>3</sub> , SO <sub>4</sub> , Cl, Si	20

Table 5 – Dushanbe polygon (Tajikistan)

Dynamic and physical parameters	Gases	Chemical composition of groundwater	Quantity
Ph, Q <sub>СКВ</sub> , H <sub>ур</sub> , T <sub>воды</sub>	H <sub>2</sub> S, He, Rn, CO <sub>2</sub>	HCO <sub>3</sub> \CO <sub>3</sub> <sup>2-</sup> , Cr	11

Table 6 – Urumqi polygon (XUAR of China)

Dynamic and physical parameters	Gases	Chemical composition	Quantity
Ph, Eh, Q <sub>СКВ</sub> , H <sub>ур</sub> , T <sub>воды</sub>	Rn, CO <sub>2</sub> , He, H <sub>2</sub> S	Cl, HCO <sub>3</sub> <sup>-</sup> , F <sup>-</sup> , SO <sub>4</sub> <sup>2-</sup> , Mg <sup>2+</sup>	15

Table 7 – Dagestan seismic polygon (Caucasus)

Dynamic and physical parameters	Gases	Chemical composition of groundwater	Quantity
Q <sub>СКВ</sub> , Ph, M	Rn, CO <sub>2</sub> CH <sub>4</sub> , H <sub>2</sub> , T <sup>°C</sup> , H <sub>2</sub> S	HCO <sub>3</sub> , Cl <sup>-</sup> , SO <sub>4</sub> <sup>2-</sup> Ca, Na, Mg	15

Table 8 – Kurile-Kamchatka polygon (Russia)

Dynamic parameters	Gases	Chemical composition of groundwater	Quantity
Q <sub>СКВ</sub> , H <sub>ур</sub>	C <sub>3</sub> H <sub>6</sub> , C <sub>2</sub> H <sub>4</sub>	HCO <sub>3</sub> <sup>-</sup> , Cl <sup>-</sup> , SO <sub>4</sub> <sup>2+</sup> , Na <sup>+</sup> , Ca <sup>2+</sup>	9

Table 9 – Japan Geochemical Monitoring Program

Dynamic parameters	Gases	Isotopes	Chemical composition of groundwater	Quantity
Gases and H <sub>ур</sub> , T <sub>воды</sub>	Rn, CO <sub>2</sub> , He	<sup>3</sup> He/ <sup>4</sup> He	Cl, SO <sub>4</sub> , K, Na, Ca, Mg, Si, B, Mo, Sr	16

Optimization of the required list of measured parameters of hydrogeochemical monitoring.

A large list of parameters on landfills has always created a lot of technical problems, as well as difficulty in the operational processing of many time series. Conducting full chemical analyses of groundwater online is difficult. Meanwhile, the experience of long-range field observations [9] makes it possible to move from initially multicomponent observations to rationally reduced, which allows significant savings in financial resources, facilitates chemical analyzes, makes fuller use of automated observation systems. The procedure of optimization of the list of measured parameters implies, first of all, to comply with the condition: “not to lose information”. It is necessary to observe such parameters that meet the following requirements:

- 1) the highest frequency of abnormal changes before earthquakes;
- 2) simple and real-time measurability of parameters in automatic mode with a data sampling frequency of at least 1 hour;
- 3) availability of a reliable instrumental base of measured parameters;
- 4) sensitive parameter response to deformation processes in locally equilibrium hydrogeochemical systems.

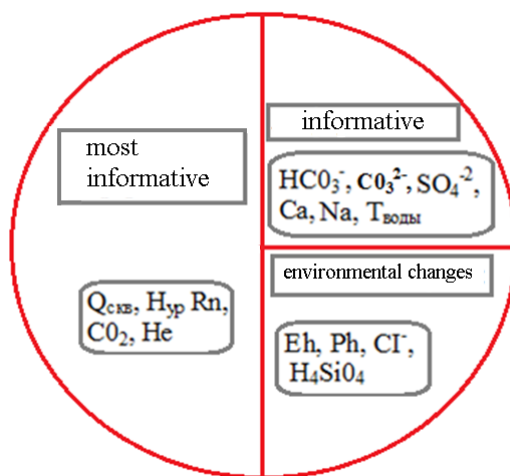

Fundamental classification of informativity of seismic and hydrogeochemical field indicators

It has been established that there is no single stable for all precursor parameter or set of hydrogeochemical parameters for all regions and polygons and even observation points, which indicates

the absence of universal precursors of earthquakes. Analysis of data for all forecasting polygons of the world shows that anomalous variations of certain parameters are not permanent indicators of earthquake preparation. Indicator in some cases, the components in other cases were not. Some earthquakes were generally not preceded by any anomalies, but occurred suddenly. However, in general, a certain range of parameters is established, which manifests itself most often when monitoring earthquakes. These include: the level of groundwater (flow rate of self-discharging wells ( $H_{level}$ ,  $Q$ ), as well as  $T_{water}$ ,  $Rn$ ,  $CO_2$ ,  $He$ ,  $Hg$ , and in the composition of groundwater  $Cl$ ,  $SO_4^{2-}$ ,  $HCO_3^-Na^+$ ,  $Ca^{2+}$  and thermodynamic indicators states of water -  $Eh$  (redox potential), as well as the cumulative parameter -  $E$ ,  $Pn$  ionic strength ( $Is$ ), groundwater (solution). The degree of relative and informativeness is presented in the figure.

Comparative data analysis of the entire list of parameters over a long observation period allows you to go from studying the seismic prognostic information content of a wide range of components to a rationally reduced list of parameters (table 10), up to 13 items (no chemistry to 7). Together, by calculating the integral indices, they give, possibly, maximum information about the real seismic situation at the landfill. In case of lack of opportunities for express chemical analyzes of water, it is possible to conduct monitoring on the basis of the necessary abbreviated list of 5 items, which can be carried out completely on an automated basis (table 11).

Table 10 – List of parameters of the complex seismic and hydrogeochemical monitoring of groundwater for predicting strong earthquakes, recommended by the results of long-term observations at the forecasting sites of Kazakhstan, Kyrgyzstan, Uzbekistan and XUAR of China

Main indicators	List of indicative parameters	Quantity
Physical parameters	$Ph, T_{water}$	2
Dynamic parameters	$Q_{hole}, H_{level}$	2
Gas components	$Rn_{water}, Rn_{soil}, CO_2, He, H_2$	4
Chemical composition	$[Na^+, Ca^{2+}], Cl, HCO_3^-, SO_4^{2-}$	5
	Total	13

Table 11 – Necessary abbreviated list of parameters of seismic and hydrogeochemical monitoring for prediction of seismic hazard in local areas of automated observation

1	Groundwater dynamics	$Q_{hole}$ or $H_{level}$	Quantity
2	Variations of radon in the surface atmosphere	$Rn_{soil}$	1
3	Through gas flows	$CO_2, H_2$	2

Such methods allow you to continuously calculate very important and sensitive integral indicators of groundwater, such as the ionic strength of the solution ( $Is$ ) and the time course of anion-cation ratios ( $P_{acr} = A/K$ ), as well as determine the radon emanation ( $Rn$ ) in water and in the surface atmosphere (soil) and their ratios. Such optimization of the list of integrated HGC monitoring fundamentally improves the quality of measurements, helps to simplify monitoring technology, significantly save material resources and speed up data processing, and also allows concentrating on the operational collection of a limited range of data and improving the short-term forecast method of strong earthquakes.

Such methods make it possible to calculate important and sensitive integral indicators of groundwater, such as the ionic strength of the solution ( $Is$ ) and the anion-cation ratio ( $P_{acr} = A / K$ ), as well as determine the radon emanation ( $Rn$ ) both in water and in the surface atmosphere (soil). Such optimization of the list of integrated HGC monitoring fundamentally improves and facilitates the monitoring technology, allowing you to significantly save material resources and speed up data processing, which leads to an improvement in the short-term forecast method of strong earthquakes. At the final stage, on the basis of such monitoring data, a seismohydro-information analytical system should be created for earthquake prediction [13].

**Conclusion.** A large list of measured parameters does not increase the information content of the landfill; moreover, it distracts for the prompt processing of a huge array of related and secondary data. In this regard, it is necessary to optimize the list of observed parameters for each water point and determine their degree of information in the general list. The key to success in this option lies in the efficiency and continuity of a limited range of parameters for a short-term forecast. In all cases, it is necessary to measure the indicators of external factors ( $R_{atm}, T_{air}$ , etc.) that affect the course of indicative parameters.

А. У. Абдуллаев<sup>1</sup>, Ш. С. Юсупов<sup>2</sup>

<sup>1</sup>ҚР БҒМ Сейсмология институты, Алматы, Қазақстан;

<sup>2</sup>Мавлянов атындағы ӨР Сейсмология институты, Ташкент, Өзбекстан

### КОМПЛЕКСТІК СЕЙСМОГИДРОГЕОХИМИЯЛЫҚ МОНИТОРИНГТІҢ САНДЫҚ КӨРСЕТКІШТЕРІН КҮШТІ ЖЕР СІЛКІНІСТЕРІН БОЛЖАУ МАҚСАТЫНДА ОҢТАЙЛАНДЫРУ

**Аннотация.** Азияның геодинамикалық болжау учаскелерінде жүргізілген сейсмикалық гидрогеохимиялық мониторингтің (СГГХМ) сандық көрсеткіштері қарастырылған. Көптеген параметрлерді үздіксіз бақылап отыру жер асты суларының бірнеше ондаған параметрлеріне бір мезгілде өлшеу негізінде жүзеге асырылатынын атап өту керек. Ең көп тараған кешен 10-15 параметрді (F, Cl, HCO<sub>3</sub>, CO<sub>3</sub>, SO<sub>4</sub>, H<sub>4</sub>SiO<sub>4</sub>, Rn, He, H<sub>2</sub>, CO<sub>2</sub>, Ph, Eh, Q<sub>сқв</sub>, Н<sub>ур</sub>, Т<sub>воды</sub>) қамтиды. Көптеген ондаған жылдар бойы бақылған ақпарат алынған ақпараттардың ақпараттылығы өлшенген параметрлер санына тәуелді емес, бірақ байқалатын су өнімдеріне сезімтал компоненттердің кумулятивтік әсерімен анықталғаны анықталды. Сондықтан тұтастай полигондар үшін бақыланып отырған параметрлер тізбесін оңтайландыру әрбір су нүктесінің ерекшеліктерін ескере отырып саралануы керек. Бұл байқау параметрлерінің санын айтарлықтай азайтуға және «балласт» индикаторларынан құтылуға мүмкіндік береді.

Бастапқыда геохимиялық (ГМ) және гидрогеологиялық мониторингтің (ГГМ) жер сілкінісіне дайындықтың танымал модельдеріне – көшкін-тұрақсыз жарықтардың пайда болуына (ЛНТ) немесе диффузиялық-дилатанттық фокустық дамуға (ДД) негізделген болатын. Зерттеушілер жер сілкінісі ошақты аймағында серпімді энергияның жинақталуының күрт артуын болжады, ол критикалық деңгейге жеткеннен кейін, сейсмикалық толқындардың пайда болуымен ортаның механикалық ажыратылуына көшеді жер сілкінісіне дейін. Бұл процесте әртүрлі салаларда – деформация, магниттік, геофизикалық, геохимиялық, гидрогеодинамикалық, геотермалдық және т.б. алдын-ала ауытқулардың кең тобы пайда болады деген сенім болды. Бұл жағдайда ГГХ және ГХ прекурсорларының пайда болуы фокустық аймақтардан сұйықтықтардың жаңа бөліктерінің келуімен немесе әртүрлі химиялық құрамдар мен газ эмменттерінің суларының араласуымен және күшті жер сілкіністерін дайындау аймағында жер қыртысының қызуымен тікелей байланысты болды. Шын мәнінде, болжамды парадигма кері есепті шешу үшін болды: болжамды жер сілкінісінің болжамды уақыты мен орнын және олардың бақыланып отырған аймақтағы даму уақытын және аномалиялардың қарқындылығымен оның ықтималдығын анықтау.

Мұндай тұжырымдама мақсатқа жетудің негізгі жолын анықтады – жер сілкінісіне дайындықты бақылау үшін арнайы полигондар құру: аймақ неғұрлым кең болса және бақылау жиынтығы неғұрлым көп болса, жер сілкінісіне дайындық белгілерін дәлірек анықтайды.

**Түйін сөздер:** сейсмикалық гидрогеохимия, мониторинг, жер сілкінісі, болжау, гидрогеохимиялық ауытқулар, ақпараттылық.

А. У. Абдуллаев<sup>1</sup>, Ш. С. Юсупов<sup>2</sup>

<sup>1</sup>Институт Сейсмологии КН МОН РК, Алматы, Казахстан;

<sup>2</sup>Институт сейсмологии АН РУз им. Мавлянова, Ташкент, Узбекистан

### ОПТИМИЗАЦИЯ КОЛИЧЕСТВЕННЫХ ПОКАЗАТЕЛЕЙ КОМПЛЕКСНОГО СЕЙСМОГИДРОГЕОХИМИЧЕСКОГО МОНИТОРИНГА С ЦЕЛЬЮ ПРОГНОЗА СИЛЬНЫХ ЗЕМЛЕТРЯСЕНИЙ

**Аннотация.** Рассмотрены количественные показатели сейсмогидрогеохимического мониторинга (СГГХМ), проводимые на геодинамических прогностических полигонах Азии. Отмечается, что непрерывное многопараметрическое наблюдение реализуется на основе одновременного измерения от нескольких до десятков параметров подземных вод. Наиболее распространенный комплекс включает в себя около 10-15 параметров (F, Cl, HCO<sub>3</sub>, CO<sub>3</sub>, SO<sub>4</sub>, H<sub>4</sub>SiO<sub>4</sub>, Rn, He, H<sub>2</sub>, CO<sub>2</sub>, Ph, Eh, Q<sub>сқв</sub>, Н<sub>ур</sub>, Т<sub>воды</sub>.) В результате анализа эффективности количественных показателей ГГХ мониторинга за многие десятилетия установлено, что информативность полученных прогнозных данных не зависит от количества измеренных параметров, и определяется совокупным эффектом чувствительных компонентов для данного водопункта наблюдения. Поэтому оптимизация перечня наблюдаемых параметров для всего полигона в целом, должна быть дифференцирована с учетом особенности каждого водопункта. Это позволяет резко сократить количество параметров наблюдения и избавляться от «балластных» показателей.

Изначально идеология геохимического (ГХ) и гидрогеологического мониторинга (ГГМ) была основана на известных моделях подготовки землетрясений – лавинно-неустойчивого трещинообразования (ЛНТ) или диффузионно-дилатантного развития очага (ДД). Исследователи предполагали, что в очаговой области землетрясений происходит скачкообразное нарастающее накопление упругой энергии, которая после достижения критического уровня переходит к механическому разрыву среды с генерацией сейсмических волн, т.е. к землетрясению. Была уверенность в том, что в этом процессе возникает широкий класс предварающих аномалий в различных полях – деформационном, магнитном, геофизическом, геохимическом, гидрогеодинамическом, геотермическом и т.д. при этом возникновение ГГХ и ГГ предвестников напрямую связывалось с поступлением новых порций флюидов из очаговых зон или смешением вод различного химического состава и газовых эманаций и прогревом земной коры в области подготовки сильных землетрясений. Собственно парадигма прогноза заключалась в решении обратной задачи: по предвестникам и временам их развития на контролируемой площади установить вероятное время и место реализации ожидаемого землетрясения, а по интенсивности проявления аномалий – его вероятную силу.

Такая концепция определила основной путь к достижению цели – создать специальные полигоны для отслеживания подготовки землетрясений по принципу: чем шире площади и больше набор наблюдения, тем надежнее обнаружение признаков подготовки землетрясений.

**Ключевые слова:** сейсмогидрогеохимия, мониторинг, землетрясения, прогноз, гидрогеохимические аномалии, информативность.

#### **Information about authors:**

Abdullaev Abdulaziz, Institute of Seismology KN MON RK, Almaty, Kazakhstan; u.abdullaev@mail.ru; <https://orcid.org/0000-0003-1975-4569>

Yusupov Sh. S., Institute of Seismology named after Mavlyanov, Academy of Sciences of the Republic of Uzbekistan, Tashkent, Uzbekistan; shuhrat-1951@mail.ru

#### **REFERENCES**

- [1] Abdullaev A.U. Fluid regime of the earth's crust as a reflection of modern geodynamic processes (for example, Tien Shan). Almaty: Evero. 2002. 352 p.
- [2] Abdullaev A.U. The development of views on the problem of forecasting earthquakes and the formation of new forecast paradigms // Geological science and industrial development of the Republic of Kazakhstan. Almaty. 2010. P.316-321.
- [3] Abdullaev A.U. To the new strategy and paradigms of earthquake prediction. Earthquake prediction, seismic hazard and seismic risk assessment of Central Asia. Almaty. 2010. P. 136-142.
- [4] Abdullaev A.U., GavShavchi, Mamyrov E.M., Grebennikova V.V., Yusupov Sh.Yu. International cooperation of hydrogeoseismologists for the monitoring of fluid parameters and prediction of strong earthquakes in the Tian-Shan seismic belt. (Proceedings of the VI International Symposium) Bishkek, 2014. P. 226-236.
- [5] Abdullaev A.U. Hydrogeochemical and hydrodynamic methods in the earthquake prediction system in Kazakhstan // Earthquake prediction. Deep geodynamics. Almaty. 1997. P. 196-220.
- [6] Abdullaev A.U. Active geochemical and hydrogeological monitoring of seismically active areas and forecasting of modern geodynamic processes // Geodynamics and geoecology of high mountain regions in the XXI. M. Bishkek. 2007. P. 70-76.
- [7] Hydrogeochemical earthquake precursors // M.: Science. 1985. 285 p.
- [8] Pulinets S.A., Uzumov D.P., Davidasko. Earthquake forecast possible // M.: "Trovan". 2014. 144 p.
- [9] Sobolev G.A. Fundamentals of Earthquake Prediction // M.: Science. 1993. 313 p.
- [10] Sobolev G.A., Ponomarev, A.V. Physics of earthquakes and precursors // M.: Science. 2003. 270 p.
- [11] Osika D.G. Fluid mode seismically active areas // M.: Science. 1981. 204 p.
- [12] Guidelines for the organization and conduct of hydrogeological observations on a specialized regional network in order to predict strong earthquakes // M.: VSEGINGEO. M: 1985. 41 p.
- [13] Abdullaev A.U., Lagutin E.I., Tukeshova G.E., Zhunisbekov T.S., Veselkina I.A., Suslova T.P., Mukhamadiev A.O., Menbayev S.M., Koblanov Z.B. The first results of the geochemical sensing tectonic faults on the basis of profile measurement of soil radon volume activity in the territory of Almaty metropolis // News of the national academy of sciences of the republic of Kazakhstan. Series of geology and technical sciences. ISSN 2224-5278. Vol. 5, N 419 (2016). P. 79-91.
- [14] Abdullaev A.U. Phase rearrangement in local balanced hydrogeochemical systems as a of fluid earthquake precursors mechanism occurrence // PERÍÓDICO TCHÊ QUÍMICA, Brazil. (2019). Vol. 16 (n°33). ISSN 2179-0302
- [15] Hydrogeochemical earthquake prominders// M.: Science. 1985. 3,197 p.
- [16] Murtazin Y.Z., Miroshnichenko O.L., Trushel L.Y. Methods of making of geoinformational and analytical system of groundwater resources in Kazakhstan // News of the National Academy of Sciences of the Republic of Kazakhstan. Series of geology and technical sciences ISSN 2224-5278. Vol. 5, N 431 (2018). P. 21-31. (In Eng.). <https://doi.org/10.32014/2018.2518-170X.2>
- [17] News of National Academy of Sciences of the Republic of Kazakhstan. Series of geology and technical sciences ISSN 2518-170X. Vol. 6, N 438(2019). P. 197-205. (In Eng.). <https://doi.org/10.32014/2019.2518-170X.171>

**NEWS**

OF THE NATIONAL ACADEMY OF SCIENCES OF THE REPUBLIC OF KAZAKHSTAN

**SERIES OF GEOLOGY AND TECHNICAL SCIENCES**

ISSN 2224-5278

Volume 2, Number 440 (2020), 21 – 30

<https://doi.org/10.32014/2020.2518-170X.27>

UDC 550.3 385.1

**A. Abetov<sup>1</sup>, Yu. Volozh<sup>2</sup>, A. Niyazova<sup>1</sup>**<sup>1</sup>Satbayev University, Almaty, Kazakhstan;<sup>2</sup>Geological Institute, Russian Academy of Sciences, Moscow, Russia.

E-mail: abetov.auez@mail.ru, niyazova.akma@mail.ru

**CORRELATION OF THE STRUCTURAL ELEMENTS  
OF MAJOR GEOSTRUCTURES OF NORTH USTYURT REGION**

**Abstract.** According to the results of research in the Ustyurt region by the nature of correlation the surface of the basement and paleozoic, the bottom of the Jurassic and Cretaceous sediments are divided into three groups of geostructures.

The first group of geostructures included mobile fold systems and “mobile corners”, in which the correlation coefficients are weak, either do not appear at all (South Emba uplift, Aral-Kyzylkum arch, Central Ustyurt dislocation system, Mountain Mangyshlak).

Second group forms internal mobile elements, isolated as large positive structures characterized by extremely high values of correlation coefficients by surface of the basement and paleozoic, the bottom of the Jurassic and Cretaceous sediments, (Buzachi uplift, Aktumsuk high, Kuanish-Koskala arch, Baychagyr-Yarkimbay high).

The third group of geostructures forms tectonic elements of the inner areas of the North Ustyurt region (North Ustyurt depression systems, Chelkar and Barsakelmess depressions), characterized by prolonged and inherited subsidence in the Phanerozoic and high correlation surface of the basement and Paleozoic, the bottom of the Jurassic and Cretaceous sediments.

**Key words:** North Ustyurt, basement, paleozoic, jurassic, cretaceous, correlation coefficient.

**Statement of the problem and a retrospective analysis.** Studies on the geological structure of the North Ustyurt basin by seismic methods and drilling began in the middle of the 20th century and conducted by various organizations of Kazakhstan, Uzbekistan, Turkmenistan, Russia. Since the 2000s – by foreign oil companies.

The first information about the geology of North Ustyurt was obtained in the early 50s after SRM (Seismic Reflection Method) and CRM (Correlation Refraction Method). According to the results of the interpretation of the data obtained, old ones were clarified and new structural elements were identified, mapped tectonic zoning of the cover and basement.

By the end of the 60s by Turlan Geophysical Expedition were performed CRM regional works, aimed at studying lower horizons of the sedimentary cover and the surface of the consolidated crust. These works allowed to determine the regional structure and the character of changes in the Paleozoic-Triassic sediments and to execute grounding by actual data, first conclusions about the structure of the basement of the Ustyurt region.

70s and 80s of the last century characterized by a significant increase in the volume of geological and geophysical works, by intense accumulation of structure data, material composition and stratigraphy of the Meso-Cenozoic and Paleozoic-Triassic sediments. During this period, regional and CDPM (Common Depth Point Method) search profiles were worked out.

By the mid-1990s, almost in the entire territory of North Ustyurt (in the Kazakh part) the development of a regional network of seismic profiles by the CRM and CDP methods was completed; a large amount of prospecting and detailed seismic works by CDP method was carried out to identify and prepare local structures in the Jurassic-Paleogene section of the sedimentary cover section.

In the eastern part of North Ustyurt, near the border with Uzbekistan, the search seismic prospecting CDPM works by MSUP was performed (with USA funding).

According to the Samsk trough, including its northern side, obtained new additional information about the geological structure. Pre-Jurassic sediments of this trough are classified as unpromising. It was concluded that the Paleozoic sediments could be a source of hydrocarbons for Jurassic sediments.

More informative material, by resolution, during seismic surveys obtained in 1995-2002, these studies were carried out by foreign investment with the most modern equipment. These areas are developed by CDPM- 2D Japanese National Petroleum Company (JNPC) and located on the northwest coast of the Aral Sea (1995-1997), in the Aral Sea (2000-2001), on the area "Teresken" in the junction zone of the Caspian Basin and Ustyurt (1997-1998) and on Kaidak litter (1999-2000).

According to the results of seismic researches and involving data on geophysical potential fields, main features of the Ustyurt tectonics were established, mapped tectonic zoning of the cover and basement and identified areas promising for oil and gas, characterized basement sediments.

Great contribution to the knowledge of the geology and petroleum potential of the North Ustyurt made articles and monographs of A. Bakirov, R. Sapozhnikov, V. Bykadorov, N. Kunin, Yu. Volozh, Z. Bulekbayev, A. Akramkhodzhayev, R. Gareckiy, R. Bykov, V.Gavrilov, I. Dalyan, N. Kalinin, L. Kirukhin, V. Knyazev, S. Ozdoyev, A. Abetov, V. Lipatova, Yu. Vasilyev, I. Grinberg, G. Dikenshtein, B. Dyakov, N. Nevolin, Ya. Ogorodnikov, V. Shraibman, A. Yanshin and et al.

However, quantitative correlation analysis of the main geological boundaries of the sedimentary cover and consolidated crust has not yet been performed. In order to study the structural features and relationships of the structural surfaces in the COSCAD 3D software package, the correlation coefficient (complete spectral correlation analysis of geodata) of a series of structural maps was calculated: by the surface of the basement, Paleozoic, pre-Jurassic surface and Cretaceous base of the North Ustyurt region.

It should be noted, what COSCAD 3D software package provides an opportunity to conduct a full spectral correlation and statistical analysis of geodata and was developed at the Moscow State Geological Prospecting University by supervision of doctors of physical and mathematical sciences, professors A. Nikitin and A. Petrov.

These studies were carried out on the basis of data of the Institute of Geological Sciences named after K.I. Satpayev (A. Abdulin, E. Votsalevsky, S. Daukeev, 1997), which were converted to digital format using software tools Didger, Surfer, ArcGIS, Geosoft.

In the geological structure of the North Ustyurt region stand out stable lumps, which include its internal regions and large linearly extended mobile belts (South Emba uplift, Aral-Kyzylkum arch, Central Ustyurt dislocation system, Mountain Mangyshlak), located in peripheral areas and in the interior "mobile corners" of this region [1].

#### **The results of correlation analyses of the main section of the North-Ustyurt region.**

**Central Ustyurt dislocation system.** Clearly expressed linear structure, stretched in a west-north-west direction and complicated by arch highs and depressions of higher orders [2].

In the central part of these dislocation systems, the surface of the consolidated basement lies at depths of 4.0 – 6.0 km (figure 1). The surface of the Paleozoic, the bottom of the Jurassic and the Cretaceous lie here conformally to the basement and with some variations are identified at depth intervals 2.5 – 3.5 km (Paleozoic surface), 1.8 – 2.0 km (bottom of the Jurassic sediments) and 1.2 – 1.6 km (bottom of the Cretaceous sediments).

The correlation coefficient between the basement and the surface of the Paleozoic everywhere gets high values (to 0.8 – 0.9) (figure 2).

On the surface of the basement and the bottom of the Jurassic formations in the western part of the Central Ustyurt dislocation system antiformal occurrence observed with a correlation coefficient – 0.4-0.6, on the rest of this large geostructure, high values of the correlation of the basement surface and the bottom of the Jurassic up to 0.8 are recorded (figure 2).

A similar pattern is observed on the surface of the basement and the bottom of the Cretaceous formations. In the western part of the Central Ustyurt dislocation system revealed negative values of correlation coefficient (up to – 0.4). The rest of this geostructure the values of the correlation coefficient increase to 0.7 (figure 2).

***Buzachi uplift.*** It stands out in the western corner of North Ustyurt and has a continuation in the waters of the Caspian Sea.

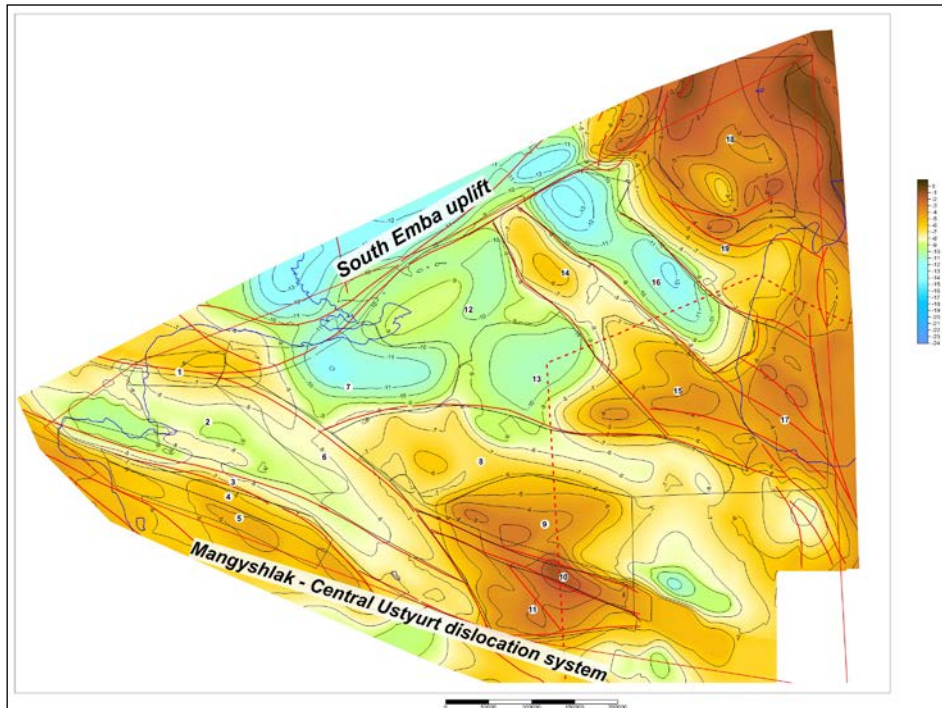

Figure 1 – Map of basement surface. *Legend:* Tectonic elements (by basement surface): 1 – Buzachi uplift; 2 – North Karatau system; 3 – Tyubkaragan-Karatau meganticlinal; 4 – Chakirgan deflection; 5 – Beke-Bashkuduk meganticlinal; 6 – Kizan-Tokubay uplift; 7 – Kultuk depression; 8 – Barsakelmess depression; 9 – Baychagyr high; 10 – Karabaur meganticlinal; 11 – Central Ustyurt system; 12 – Zhayilgan uplift; 13 – Sams depression; 14 – Amanzhol-Sheluran high; 15 – Aktumsuk uplift; 16 – Kosbulak depression; 17 – Aral-Kyzylkum system; 18 – Chelkar depression; 19 – Akkul high

In the North-West of the Buzachi uplift the surface of the basement is traced at depths about 6.0-7.0 km, submerged up to 8.0 km in the southern and eastern directions (figure 1).

In hypsometrically elevated areas of this uplift the basement is weakly correlated with the surface of the Paleozoic formations (0.2), whereas this coefficient increases in a southerly direction to 0.6 (figure 2).

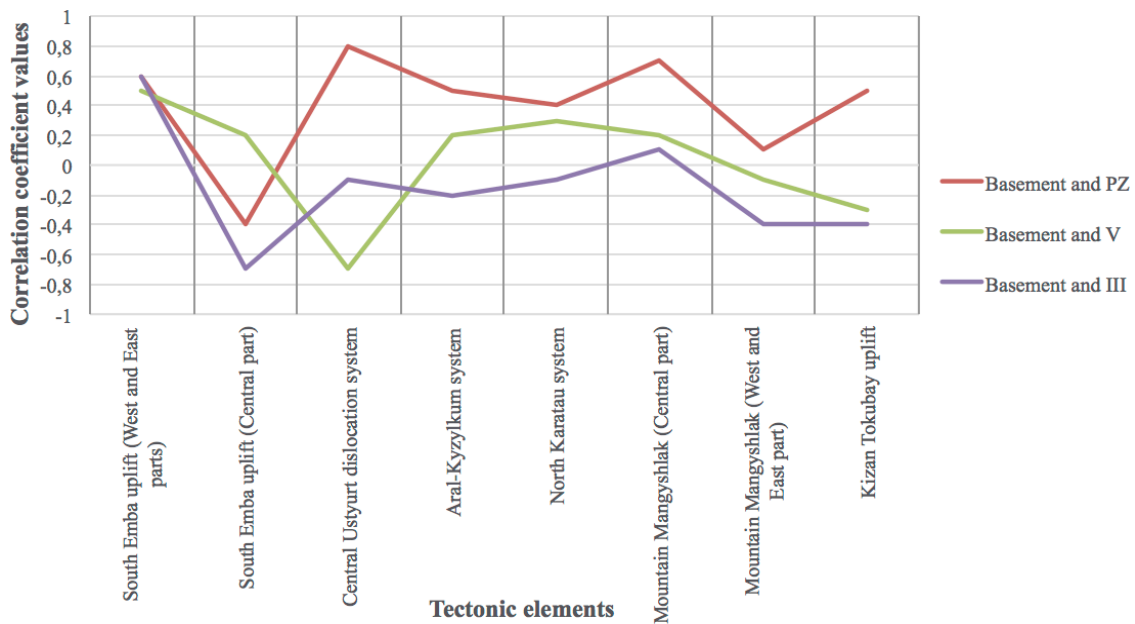

Figure 2 – Graph of average values of the correlation coefficients of the «mobile corners» of the North Ustyurt region

Paleozoic sediment complexes are widely developed here. In the arch of the Buzachi uplift, the surface of the Paleozoic formations lies at depths of up to 2.5 km and more, plunging to 6.5–7.0 km on the southern and eastern pericline of this uplift.

The bottom of the Jurassic sediments stands out at depths of up to 0.6 km in the North-West part of the Buzachi uplift, submerged to south and east to 1.6 km. The depth range of the bottom of the Cretaceous formations varies within 0.6 – 1.2 km.

There is a good correlation between the bottom of the Jurassic and Cretaceous sediments with the basement surface (0.6 – 0.7) (figure 3).

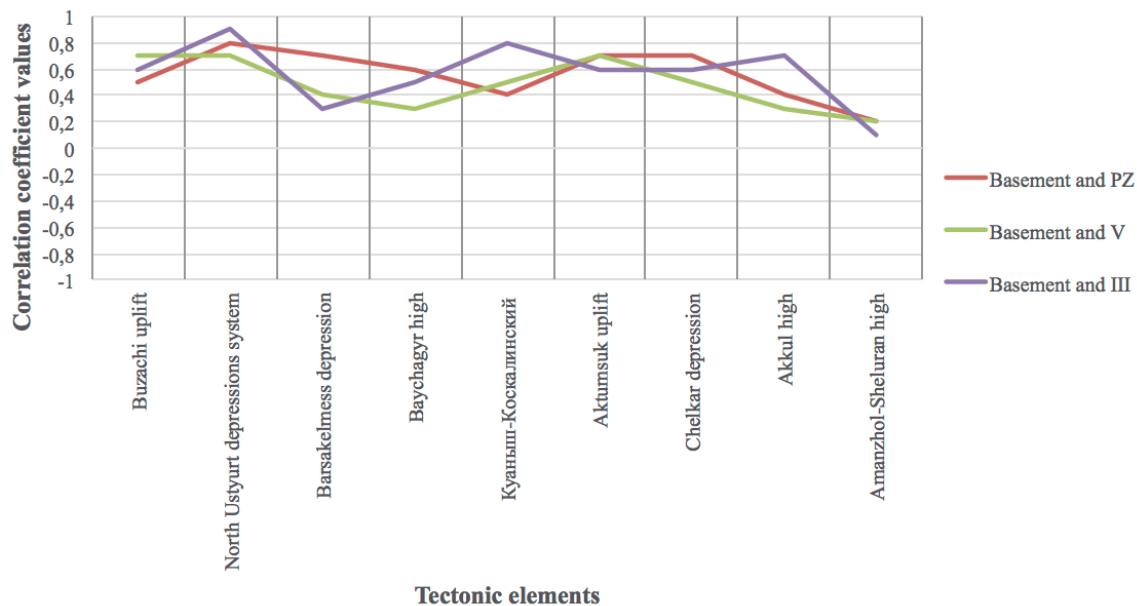

Figure 3 – Graph of average values of the correlation coefficients of the internal ares of the North Ustyurt region

**Mountain Mangyshlak.** Formed along the Scythian-Turanian planetary lineament [3]. The depth of the basement here is sustained everywhere and takes values of 6.0 – 7.0 km (including North Karatau and Chakirgan troughs) (figure 1). The elevations of Mountain Mangyshlak are separated in the form of narrow (about 20 km) and extended (up to several hundred km) elevations — meganticlines [4].

The surface of the Paleozoic Mountain Mangyshlak is separated at depths of 3.0 – 4.5 km and more.

The correlation coefficients of the basement and the surface of the Paleozoic take minimum values (from 0.1 to -0.6) on the northwestern and southeastern flanks. In the central part of the Mountain Mangyshlak, the basement and surface of the Paleozoic lies conformally with a high correlation coefficient (up to 0.8) (figure 2).

In the relief of the bottom of the Jurassic sediments, Mountain Mangyshlak is isolated in the form of elevation in absolute elevations -1.6 – 2.0 km. The correlation coefficients of the basement and the bottom of the Jurassic sediments are distributed in a similar way. The lack of correlation of these boundaries is observed in the north-western and south-eastern parts (-0.3 – 0.1), whereas in the rest of the Mountain Mangyshlak their weak correlation is recorded (0.2 – 0.4) (figure 2).

On the bottom of the Cretaceous sediments, the eastern part of Mountain Mangyshlak is raised to 0 km, with immersion in a north-west direction to 2.0 km.

The bottom of the Cretaceous formations lies non-conformally with the above-described interfaces and is characterized by the absence of correlation, values of which reach here extremely high values (up to -0.9) (figure 2), which, in turn, gives grounds to assume a significant restructuring of the structural plan on the border of the Jurassic and the Cretaceous.

**South Emba uplift.** Splits the Caspian depression and the North Ustyurt massif and in the form of a narrow inversion structure extends in the northeast direction [5].

In the axial part of the South Emba uplift, the surface of the basement is submerged to 12.0- 13.0 km, whereas on the northern and southern flanks of this uplift it is raised to depths of 9.0 – 10.0 km and less (figure 1).

In the relief of the surface of Paleozoic formations, the South Emba uplift is isolated in the form of a large anticlinorium with a depth of surface of the Paleozoic formation of 1.5–4.5 km, in separate areas, up to 0.5 km.

The surface of the basement and Paleozoic deposits almost the entire territory of South Emba uplift occur antiformally and do not correlate among themselves (-0.4 – 0.1) (figure 2).

The depth of the bottom of the Jurassic sediments South Emba uplift can be divided into three areas. The most curved position of the bottom of the Jurassic formations was recorded in the central part of the South Emba uplift (3.0 – 3.2 km). From here it rises to 0.6 – 2.0 km on its south-western flank and up to 1.2 – 1.6 km, respectively, on the northeastern flank.

The surface of the basement with the bottom of the Jurassic sediments is correlated by positive values of the coefficient (up to 0.7), having only in the central part the reduction of this coefficient to 0.1, which indicates a weakening of the correlation of the basement surface and the bottom of the Jurassic sediments (figure 2).

The bottom of the Cretaceous sediments has a similar pattern in depth. In the southwestern part of the South Emba uplift, it occupies a hypsometrically elevated position of up to 0.6 km. In the north - eastern part it takes an intermediate position and in the central part is submerged to 1.4 – 1.8 km.

**Aral-Kyzylkum tectonic rampart (dislocation system).** On the surface of the basement, it manifests itself as a large polygonal array with the depth of the basement up to 6.0 km (figure 1).

In the relief of the surface of the Paleozoic in most of its stretch Aral-Kyzylkum arch shows itself as an uplift with an unclearly pronounced linear form and the depth of submergence of this surface to 4.5 – 5.0 km.

There is a confident correlation between the surfaces of the basement and the Paleozoic (0.5 – 0.7), decreasing to 0.1 in the southeast of this shaft (figure 2).

The bottom of the Jurassic sediments lies in the anti-formal underlying sediments and has a deepening trend in a westerly direction from 1.8 to 3.4 km. The Aral-Kyzylkum arch in the relief of this surface acquires a clearly expressed linear shape. The correlation coefficients of the basement with the bottom of the Jurassic formations vary in the range 0.1 – 0.6 (figure 2).

A close tendency is manifested in the behavior of the surface of the Cretaceous sediments of the Aral-Kyzylkum arch, which also deepens in a westerly direction from 1.6 to 2.4 km.

The basement with the bottom of the Cretaceous sediments practically does not correlate (to -0.1-0.4). And only, on separate squares on the western and eastern flanks of the Aral-Kyzylkum arch, the values of this coefficient increase to 0.5 (figure 2).

**Aktumsuk dislocation system and Kuanish-Koskala tectonic rampart** on the surface of the basement are separated at depths of 5.0 – 7.0 km (figure 1).

In the relief of the surface of the Paleozoic, they manifest themselves as elevations with hypsometric values of depth within 3.5 – 4.0 km. In the central part of the Kuanish-Koskala tectonic rampart, the surface of Paleozoic formations is up to 5.0 km.

The correlation coefficient between the surfaces of the basement and the Paleozoic takes on quite high values (up to 0.6 – 0.8). In the central part of Kuanish-Koskala arch, a decrease in the correlation of these interfaces to 0.1 (figure 3).

On the bottom of the Jurassic, Aktumsuk shaft is an uplift, which stands apart in a depth range of 2.2 – 2.6 km. The Kuanish-Koskala arch is notable for stable depths of the bottom of the Jurassic sediments (2.0 to 2.4 km).

High correlation links are established for the Aktumsuk dislocation system (up to 0.7) between the surface of the basement and the bottom of the Jurassic deposits. On Kuanish-Koskala arch, the values of the correlation coefficient are reduced to 0.5 (figure 3).

On the bottom of the Cretaceous sediments Aktumsuk dislocation system is isolated at depths of 1.6 – 1.8 km, Kuanish-Koskala arch at 1.8 – 2.0 km. The correlation coefficient reaches extremely high values (0.7 – 0.8) (figure 3).

**Chelkar depression.** Located on the northeastern flank of the North-Ustyurt region. The sides of this trough are complicated by uplifts, groups of structures, structural terraces, anticlines and brachyanticlines [6].

In most of the depression, the depth of the basement is set in the range of 2.0 – 3.0 km. Two troughs are distinguished in the depression: Kurgantuz and Arradung. The Kurgantuz trough has a simple structure and a basement depth of up to 4.0 km. Arradung - characterized by a complex internal structure. The basement surface is submerged here to a depth of 6.0 km (figure 1) [2].

On the surface of the Paleozoic, the Chelkar depression is separated by isogypsy -1.5 – 2.0 km. In the Arradung trough, its depth is set to 5.0 km. In the Kurgantuz trough to 3.5 km.

The basement and surface of the Paleozoic in the Chelkar depression lies conformally with a high correlation coefficient (0.6 – 0.8) (figure 3).

In the relief of the bottom of the Jurassic sediments in the side zones of the Chelkar depression, the desired surface stands out at depths of 1.0 – 1.4 km. In the depot centers of this trough, it deepens to 4.0 km in the Arradung trough and to 2.4 – 2.6 km of the Kurgantuz trough.

The correlation of the basement with the bottom of the Jurassic formations in the Chelkar trough decreases to 0.4 – 0.7 (figure 3).

The bottom of the Cretaceous sediments of the Chelkar trough separates at depths 0.8-1.2 km. Submerged to 2.8 km in Arradung trough. There is a high correlation between the bottom of the Cretaceous sediments and the basement (0.6 – 0.8) (figure 3).

**Barsakelmess depression.** On the surface of the basement is a difficult - built asymmetric structure with steep north and northeast (8.0 – 9.0 km) and gentle south-west (6.0 – 7.0 km) sides (figure 1) [7].

On the surface of the Paleozoic, there is a trend of submergence in the north direction from 4.0 to 6.5 km. Correlation coefficients reach extremely high values 0.8 – 0.9 (figure 3).

In the relief of the bottom of the Jurassic sediments, most of the Barsakelmess depression is isolated in the form of depression, oriented in the north - east (3.0 – 3.6 km) direction, whereas in the western, lateral part, there is uplift of the bottom of the Jurassic sediments (2.4 km).

In most parts of the Barsakelmess depression, high values of the correlation coefficients of the basement and the bottom of the Jurassic sediments are recorded (0.6- 0.8). Exceptions are its western and southeastern parts, where these boundaries are not correlated (correlation coefficients are reduced to - 0.4-0.1) (figure 3).

The trend of deepening in the north-east direction is also observed on the bottom of the Cretaceous sediments (1.8 – 2.4 km). The values of the correlation coefficient between the basement and the Cretaceous bottom in the inner regions of the deflection reach here extremely high values (to 0.8 – 0.9), dropping to -0.2 in the western and southeastern parts (figure 3).

**Baichagyr-Yarkimbay arch.** Large positive element, bounding Barsakelmess trough from the west and having a massive configuration and slight development of structural complications in the sedimentary cover [6].

In most of this arch, the surface of the basement submerged to north from 4.0 to 6.0 km (figure 1).

In the relief of the surface of the Paleozoic formations, the Baychagyr-Yarkimbay arch is isolated at depths 3.0 – 3.5 km.

The surface of the basement and Paleozoic sediments over almost the entire territory of this arch lie conformally and correlate well with the values of the correlation coefficients 0.6 – 0.8 (figure 3).

The bottom of the Jurassic deposits of the Baychagyr-Yarkimbay arch is uplift in the northeast direction from 2.2 to 3.0 km.

The high correlation of the basement with the bottom of the Jurassic sediments is established (to 0.7 – 0.8). And, only, in the western part of the Baichagyr-Yarkimbay arch, a decrease in the correlation of these surfaces to 0.1 (figure 3).

The bottom of the Cretaceous sediments has a similar correlation trend with the basement surface. It occupies a hypsometrically elevated position in the southwestern part of the Baychagyr-Yarkimbay arch (to 1.2 km), in the northeast, up to 1.8 km. The correlation coefficient here gets high values (to 0.6 – 0.8) and only, on the northeast flank of this arch, the values of this coefficient are reduced to -0.1 (figure 3).

**North Ustyurt depressions system** formed by the Sam and Kosbulak troughs and the Kultuk depression. This depression system is characterized by deep basement submergence (up to 10.0 – 12.0 km and more) (figure 1) [7; 13-20].

To the south, by the complex system of large-amplitude faults, the surface of the bottom rises sharply

to a depth of 7.0 – 8.0 km in Kyzan-Tokubay uplift and up to 6.0 – 7.0 km of the Aktumsuk dislocation system.

To the north, in the relief of the basement surface of this system of depressions, there is no physical boundary with the South Emba uplift (12.0 – 13.0 km) (figure 1).

In the surface relief of the Paleozoic deposits, the Kosbulak and Sam troughs are isolated at depths 5.5 – 6.5 km and 6.5 – 7.5 km, respectively, and the Kultuk depression to 7.0 – 8.0 km.

In the North Ustyurt depressions system, in North Ustyurt depressions system exhibits high values of correlation coefficient basement surface and Paleozoic (to 0.8), which decreases to the border with the South Emba uplift to 0.1 (figure 3).

The bottom of the Jurassic sediments over most of the North Ustyurt depressions system are separated at depths of 3.6 – 4.2 km. The correlation coefficient between the basement surface and the bottom of the Jurassic sediments acquire high values (to 0.7), in some places reaching a maximum (0.9) (figure 3).

In the relief of the Cretaceous bottom, this system of deflections is separated at depths 1.8 – 3.0 km. There are high values of correlation coefficients to 0.8 – 0.9 (figure 3).

**Conclusion.** Conducted studies to identify correlations of structural elements within major geostructures of the North Ustyurt region give grounds for the formulation of the following conclusions:

In linearly extended mobile systems and mobile corners, the correlation of the basement surface and Paleozoic formations, the bottom of the Jurassic and Cretaceous sediments are weak, or not at all. Here, these interfaces often lie antiformally.

For example, the Aral-Kyzylkum system of uplifts in the surface structure of the basement and Paleozoic manifests itself as an arch, whereas in the structure of the Jurassic and Cretaceous sediment complexes it is isolated as a submerged depression.

The South Emba uplift in the sediments of the Upper Paleozoic and Mesozoic-Cenozoic deposits is arch, whereas in the relief of the basement surface it manifests itself as a deep trough.

The conformal occurrence of the surface of the basement and the Paleozoic and the bottom of the Jurassic deposits in the form of highs identified in the Central Ustyurt dislocation system, the central part of the Mountain Mangyshlak. The bottom of Cretaceous sediments is not correlated or weakly correlated with the above boundaries.

The exceptions are the Buzachi arch, Aktumsuk swell, Kuanish-Koskala tectonic rampart and Baichagyr-Yarkimbay arch, characterized by extremely high values of correlation coefficients, manifest themselves as large positive structures along all analyzed interfaces.

In the interior of the North Ustyurt region (North Ustyurt depressions system, Chelkar and Barsakelmess depression), characterized by prolonged and inherited subsidence in the Phanerozoic, observed the curved position of the surface of the basement and the Paleozoic, bottom of the Jurassic and Cretaceous with high values of the correlation coefficient.

А. Е. Абетов<sup>1</sup>, Ю. А. Волож<sup>2</sup>, А. Т. Ниязова<sup>1</sup>

<sup>1</sup>Satbayev University, Алматы, Қазақстан;

<sup>2</sup>РФА Геологиялық институты, Мәскеу, Ресей

### СОЛТҮСТІК ҮСТІРТ Өңірінің ірі геоқұрылымдарының құрылымдық элементтерінің корреляциясы

**Аннотация.** Жұмыста бұрын жүргізілген шөгінді жамылғының және шоғырланған жер қыртысының негізгі геологиялық шекараларын сандық корреляциялық талдау нәтижелері келтірілген. COSCAD 3D бағдарламалық пакетіндегі құрылымдық беткейлердің құрылымдық ерекшеліктері мен қатынастарын зерттеу үшін бірқатар құрылымдық карталардағы корреляция коэффициенті (спектрлік корреляциялық талдау) есептелді: іргетас беті, палеозой, юраға дейінгі беткей, Солтүстік Үстірт аймағының бор негізі.

COSCAD 3D бағдарламалық пакеті геодатаға толық спектрлік-корреляциялық және статистикалық талдау жүргізуге мүмкіндік береді және Мәскеу мемлекеттік геологиялық барлау университетінде физика-математика ғылымдарының докторлары, профессор А.А. Никитин және А.В. Петров жетекшілігімен жасалған.

Солтүстік Үстірт аймағының геологиялық құрылымында перифериялық аймақтар мен құрлықта орналасқан ішкі аймақтарды және ірі сызықты созылған жылжымалы аймақтарды (Орталық Үстірттің дислокация жүйесі, Таулы Маңғышлақ, Оңтүстік Ембі көтерілісі және Арал Қызылқұм валдары) қамтитын тұрақты блоктар бөлінеді. Осы аймақтың «жылжымалы бұрыштары».

Орындалған зерттеу нәтижелері бойынша Үстірт өңірінде жоғарғы іргетас және палеозой, юра және бор табандарының корреляция мәніне байланысты үш геоструктуралық топ бөлінеді.

Бірінші геоструктуралық топқа жылжымалы қатпарлы жүйе және «мобильді бұрыштар» кіреді, жоғарыда айтылған шектерде корреляция коэффициенті әлсіз танылады немесе мүлдем танылмайды (Оңтүстік Ембі көтерілімі, Арал-Қызылқұм белесі, Орталық Үстірт дислокация жүйесі, Таулы Маңғышлақ). Мысалы, Арал-Қызылқұм жүйесі жоғарғы және төменгі жақтардың бәріне көтеріліп, өзін көтерілім ретінде көрсетті, ал юра және бор кешендері құрылымында тау асты депрессиясы ретінде оқшауланған.

Іргетас пен палеозойдың беткейлері мен юра түбінің шығыңқы түрінде конформды түрде пайда болуы Таулы Маңғышлақтың орталық бөлігіндегі орталықтанған жүйесінде анықталды. Бор шөгінділерінің табаны жоғарыда аталғандармен байланыстырылмаған немесе нашар байланысқан.

Мысалы, Арал-Қызылқұм жүйесі іргетас пен палеозойдың құрылымындағы көтерілістер жүйесі пандус түрінде көрінеді, ал юра және бор кезеңіндегі тау жыныстарының кешендерінің құрылымында ол жерасты депрессиясы ретінде бөлінеді.

Жоғарғы палеозой және мезозой-кайнозой шөгінділерінің құрылымындағы Оңтүстік Ембі көтерілісі - бұл қорған, ал жертөле бетінің рельефінде ол терең құлату ретінде көрінеді.

Екінші топ – ішкі мобильді топты құрайды, ірі оңтайлы құрылымдар болып жекеленетін және іргетас бетінің палеозоймен, юра және бор шөгінділерімен корреляция коэффициентінің экстремалды жоғары мәндерімен сипатталады (Бұзашы төбесі, Ақтұмсық көтерілімі, Қуаныш-Қосқала белесі, Байшағыр-Ярқымбай төбесі).

Жер асты және палеозой бетінің және юра шөгінділерінің шығыңқы түрінде конформды кездесуі Орталық Үстірт дислокация жүйесінде, Таулы Маңғышлақтың орталық бөлігінде анықталды. Бор қабаттарының табаны жоғарыда аталған интерфейсмен байланыстырылмаған немесе нашар байланысқан.

Бұзашы, Ақтұмсық көтерілісі, Қуаныш-Қосқала шыңы және Байшағыр-Ярқымбай арка ерекшеліктері корреляция коэффициенттерінің өте жоғары мәндерімен сипатталады, барлық талданған аудандарда үлкен позитивті құрылымдар ретінде көрінеді.

Үшінші геоструктуралық топты Солтүстік Үстірт өңірінің ішкі ауданының тектоникалық элементтері құрайды (Солтүстік Үстірт иілім жүйесі, Шалқар және Барсакелмес депрессиялары), ұзақ және мұралы иілумен және ең көп іргетас бетінің палеозой, юра және бор шөгінділері корреляциясымен сипатталады.

Солтүстік Үстірт аймағының ішкі аймақтарында (Солтүстік Үстірт депрессия жүйесі, Шалқар және Барсакелмес ойпаттары) олар фенерозойда ұзақ және мұраланған ауытқумен сипатталады, іргетаспен қисық орналасуы және корреляция коэффициентінің жоғары мәндері бар палеозой, юра және бор табандары байқалады.

**Түйін сөздер:** Солтүстік Үстірт, іргетас, палеозой, юра, бор, корреляция коэффициенті.

**А. Е. Абетов<sup>1</sup>, Ю. А. Волож<sup>2</sup>, А. Т. Ниязова<sup>1</sup>**

<sup>1</sup>Satbayev University, Алматы, Казахстан;

<sup>2</sup>Геологический институт РАН, Москва, Россия

### **КОРРЕЛЯЦИЯ СТРУКТУРНЫХ ЭЛЕМЕНТОВ КРУПНЫХ ГЕОСТРУКТУР СЕВЕРО-УСТИОРТСКОГО РЕГИОНА**

**Аннотация.** В работе отображены результаты количественного корреляционного анализа основных геологических границ осадочного чехла и консолидированной коры. В целях изучения структурных особенностей и взаимоотношений структурных поверхностей в программном комплексе COSCAD 3D рассчитаны коэффициент корреляции (полный спектрально-корреляционный анализ геоданных) серии структурных карт: по поверхности фундамента, палеозоя, доюрской поверхности, подошве мела Северо-Устиортской региона.

Программный комплекс COSCAD 3D дает возможность провести полный спектрально-корреляционный и статистический анализ геоданных и был разработан в Московском Государственном геологоразведочном Университете под руководством докторов физико-математических наук, профессоров А.А. Никитина и А.В. Петрова.

В геологическом строении Северо-Устьюртского региона выделяются стабильные глыбы, к которым относятся его внутренние районы и крупные линейно-вытянутые мобильные пояса (Центрально-Устьюртская система дислокаций, Горный Мангышлак, Южно-Эмбенское поднятие и Арало Кызылкумский вал), расположенные в периферийных зонах и внутренних «мобильных углах» этого региона.

По результатам выполненных исследований в Устьюртском регионе, по характеру коррелируемости поверхности фундамента и палеозоя подошвы юрских и меловых отложений выделены в три группы геоструктур.

В первую группу геоструктур вошли подвижные складчатые системы и «мобильные углы», в которых коэффициенты корреляции вышеуказанных границ проявляются слабо либо не проявляются вовсе (Южно-Эмбенское поднятие, Арало-Кызылкумский вал, Центрально-Устьюртская система дислокации, Горный Мангышлак). К примеру, Арало-Кызылкумская система поднятий в структуре поверхностей фундамента и палеозоя проявляет себя как вал, тогда как в строении юрских и меловых комплексов пород обособляется как погруженная депрессия.

В линейно-вытянутых подвижных системах и мобильных углах коррелируемость поверхности фундамента и палеозойских образований, подошвы юрских и меловых отложений проявляется слабо либо не проявляется вовсе. Здесь эти границы раздела зачастую залегают антиформно.

К примеру, Арало-Кызылкумская система поднятий в структуре поверхностей фундамента и палеозоя проявляет себя как вал, тогда как в строении юрских и меловых комплексов пород обособляется как погруженная депрессия.

Южно-Эмбенское поднятие в структуре отложений верхнего палеозоя и мезозоя-кайнозоя представляет собой вал, тогда как в рельефе поверхности фундамента проявляет себя как глубокий прогиб.

Вторую группу формируют внутренние мобильные группы, обособляющиеся как крупные положительные структуры, характеризующиеся экстремально высокими значениями коэффициентов корреляции по поверхности фундамента и палеозоя, подошвы юрских и меловых отложений, (Бузачинский выступ, Актумсукское поднятие, Куаныш-Коскалинский вал, Байчагыр-Яркимбайский свод).

Конформное залегание поверхности фундамента и палеозоя и подошвы юрских отложений в виде выступов выявлено в Центрально-Устьюртской системе дислокаций, центральной части Горного Мангышлака. Подошва меловых отложений не коррелируется или слабо коррелируется с вышеописанными границами раздела.

Исключение составляют Бузачинский выступ, Актумсукское поднятие, Куаныш-Коскалинский вал и Байчагыр-Яркимбайский свод, характеризующиеся экстремально высокими значениями коэффициентов корреляции, проявляют себя как крупные положительные структуры по всем анализируемым границам раздела.

Третью группу геоструктур образуют тектонические элементы внутренних районов Северо-Устьюртского региона (Северо-Устьюртская система прогибов, Челкарская и Барсакельмесская депрессии), характеризующиеся длительным и унаследованным прогибанием в фанерозое и высокой коррелируемостью поверхности фундамента и палеозоя, подошвы юры и мела.

Во внутренних районах Северо-Устьюртского региона (Северо-Устьюртская система прогибов, Челкарская и Барсакельмесская депрессии), характеризуются длительным и унаследованным прогибанием в фанерозое, наблюдаются прогнутое положение поверхности фундамента и палеозоя, подошвы юры и мела с высокими значениями коэффициента корреляции.

**Ключевые слова:** Северный Устьюрт, фундамент, поверхность палеозоя, подошва юры, подошва мела, коэффициент корреляции.

#### **Information about authors:**

Abetov Auez, Geophysics Department Chairman, Satbayev University, Doctor of Sciences in Geology and Mineralogy, Professor, Almaty, Kazakhstan; abetov.auez@mail.ru; <https://orcid.org/0000-0002-1866-7677>

Volozh Yuriy, corresponding member of Russian Academy of Sciences, Doctor of Sciences in Geology and Mineralogy, Professor, Moscow, Russia; yvolozh@yandex.ru; <https://orcid.org/0000-0001-8304-9069>

Niyazova Akmaral, 3rd year doctoral student of Geophysics Department Satbayev University, niyazova.akma@mail.ru; <https://orcid.org/0000-0002-3241-5193>

**REFERENCES**

- [1] Abetov A., Niyazova A., Saurikov Zh. 3D Modeling of Euler's points for Geodensity and Geomagnetic models of North Ustyurt region in Geosoft Oasis Montaj software // *News of the National Academy of Sciences of the Republic of Kazakhstan. Series of geology and technical sciences.* Vol. 6, N 426. 2017. P.171-177 (in Russ.). ISSN 2224-5278
- [2] Babadzhonov T., Kunin N., Luk-Zilberman V. Stroenie i neftegazonosnost' glubokopogruzhennykh kompleksov Srednei Azii po geofizicheskim dannym // Tashkent: Fan, 1986. 190 p.
- [3] Zholtayev G., Iskaziev K., Abayildanov B. Paleosoic deposits as option for reserves replacement and expansion of raw material base for the petroleum industry in Mangyshlak // *News of the National Academy of Sciences of the Republic of Kazakhstan. Series of geology and technical sciences.* Vol. 5, N 431. 2018. P. 163-171 (in Eng.). ISSN 2224-5278 <https://doi.org/10.32014/2018.2518-170X.22>
- [4] Akramkhodzhaev A., Grinberg I., Sukhinin V., Yuldashev Zh., Valiev A. Neftegazonosnost' Severo-Ustyurtskoi vpadiny // Tashkent: Fan, 1974. 81 p.
- [5] Li Yun Khun. Geologicheskoe stroenie i perspektivy neftegazonosnosti jugo-vostochnogo borta Prikaspijskoj vpadiny i ee obramlenija // M.: MSU, 2006. 152 p.
- [6] Peive A., Markov M., Menner V. Problemy regional'noj tektoniki Evrazii // *Academy of sciences of USSR, Institut of geology.* 1963. N 92 (in Russ.).
- [7] Abetov A., Niyazova A. Regional'nye osobennosti geologicheskogo stroenija Severnogo Ustjurta po dannym gravirazvedki // *Actual problems of geology, geophysics and metallogeny.* Kn. 3. 2017. P. 91-95 (in Russ.).
- [8] Bykadorov V., Volozh Yu., Miletenko N., Fedorenko O. Tektonicheskaja evolyucija i paleogeografija Severnogo Ustjurta v paleozoe I mezozoe // *Materials of 36<sup>th</sup> tect. meeting: tectonic and geodynamic of continental crust.* M., 2003. P. 86-89 (in Russ.).
- [9] Leonov Yu., Volozh Yu., Antipov M., Bykadorov V., Heraskov T. Konsolidirovannaja kora Kaspijskogo regiona: opyt rajonirovaniya. GISRAS, M.. 2010. 63 p. (in Russ.).
- [10] Authors, Redactors Uzhkenov B., Antonyuk R., Bykadorov V., Volozh Yu. And et. al. Map of Alpien tectonic of Kazakhstan. Committee of geology of Kazakhstan, Almaty. 2012.
- [11] Volozh Yu., Bykadorov V., Antipov M., Parasina V., Ribalchenko V. Stroenie I neftegazonosnost paleozoiskikh otlozhenii Ustjurta // *Oil and Gas.* 2013. N 5. P. 85-97 (in Russ.).
- [12] Volozh Yu., Bykadorov V., Antipov M., Sapozhnikov R. Osobennosti stroenija paleozoiskikh otlozhenij Turgaisko-Sirdarinskogo I Ustyurtskogo regionov (v svyazi perspektivami neftegazonosnosti glubokih gorizontov osadochnogo chehla) // *Oil and gas Geology. Teory and Pracice.* Spb. 2016. N 4. P. 1-43, figure 16.
- [13] Aliyev I.M., Arzhevsky G.A., Grigorenko Yu.N. Oil and gas provinces of the USSR: Manual. M.: Nedra. 1983. 272 p.
- [14] Hood P. Gradient measurements in aeromagnetic surveying. *Geophysics*, 1965. Vol. XXX. P. 891-902.
- [15] Thompson D.T. EULDPH: A new technique for making computer-assisted depth estimates for magnetic data. *Geophysics*, 1982. Vol. 47. P. 31-37.
- [16] Reid A.B., Allsop J.M., Grancer H. Magnetic interpretation in three dimensions using Euler deconvolution. *Geophysics*, 199. Vol. 55. P. 80-90.
- [17] Richard Taylor. Interpretation of Correlation Coefficient: A Basic Review. *SAGE journals*, 1990. Vol. 6. P. 35-39. ISSN 8756-4793. <https://doi.org/10.1177/875647939000600106>
- [18] Gogtay N.J., Thatte U.M. Principles of Correlation Analysis. *Journals of the Association of Physicians of India*, 2017. Vol. 65. P. 78-81.
- [19] Nevolin N. Tectonika Ustjura [Tectonic of Ustyurt]. *Oil and gas geology.* 1958. N 7. P. 12-18.
- [20] Tal-Virsky B.B. Geophysical fields and tectonics of Central Asia. M.: Nedra. 1982. 200 p.

**NEWS**

OF THE NATIONAL ACADEMY OF SCIENCES OF THE REPUBLIC OF KAZAKHSTAN

**SERIES OF GEOLOGY AND TECHNICAL SCIENCES**

ISSN 2224-5278

Volume 2, Number 440 (2020), 31 – 39

<https://doi.org/10.32014/2020.2518-170X.28>

UDC 550.8

IRSTI 38.57.17

**A. B. Baibatsha<sup>1</sup>, A. Muszynski<sup>2</sup>**<sup>1</sup>Satbayev University, Almaty, Kazakhstan;<sup>2</sup>Adam Mickiewicz University, Poznan, Poland.

E-mail: baibatsha48@mail.ru, anmu@amu.edu.pl

**GEOLOGICAL-GEOPHYSICAL PROSPECTING INDICATORS  
OF THE ARGANATY DISTRICT PREDICTIVE BLOCKS  
(EASTERN BALKHASH)**

**Abstract.** Ground-based magnetic exploration and electrical exploration geophysical studies are carried out on the predicted areas of the Arganaty district (Eastern Balkhash), revealed by the cosmological methods. The area is in the zone of influence of Zhongar geosuture. Paleozoic rock masses developed in the area, starting from the Silurian to Serpukhov-Middle Carboniferous. By a qualitative interpretation of magnetic data, a number of local and linear anomalies identified. Electrical exploration made it possible to construct pseudo-sections of primary data, pseudo-sections of 2D inversion in three profiles. At one of the projected sites, it was possible to establish a contact of the intrusion hidden beneath the sediments, presumably of an average composition with the volcanic-sedimentary rocks enclosing it. Both in the endo- and in the exocontact of the intrusion, by the presence of local magnetic anomalies and anomalies of induced polarization (IP), areas, presumably sulphide mineralization, were established. It is recommended to drill prospecting wells in these areas.

**Key words:** Magnetic exploration, Electrical exploration, Anomaly, Buried granitoid, Sulphide mineralization, Prospecting drilling.

**Introduction.** The Arganaty district is located in the Eastern Balkhash region, on the territory of the Alakol area of the Almaty region. The relief of the site is flat, in places it is slightly hilly. Most of the area is occupied by ridge and hilly-dune sands, fixed by grassy, sometimes shrub vegetation. A low-mountain plateau rises among the plains, the marginal parts of which are named after the Arganaty, Arkharly, Kyskash mountains with the highest absolute altitudes of 700-750 m. The northern slopes of the Arganaty mountains are steep, sharply dissected by a thick network of ravines, separated from the adjacent plain from the north by a tectonic ledge 100-150 m high. They are limited to a high tectonic bench and are similar in nature to the Arganaty mountains.

In the geological structure of the studied territory, the oldest deposits are the Silurian system, which is represented by the sediments of the Wenlock series, which form a small tectonic block in the zone of the regional Zhongar fault on the northern edge of the Arganaty mountains. As part of the Wenlock series, a pack of normal-sedimentary rocks – siltstones, limestones, calcareous sandstones, and a bundle of tuffogenic-pyroclastic rocks: crystalline and ash tuffs of acidic composition interbedded with tuffogenic sandstones are distinguished. The Devonian system is represented by sediments of the Eiffel stage, which are known on the northern edge of the Arganaty mountains, where they are separated by tectonic contact from the Wenlock series. Tuffogenic sandstones and siltstones consisting of angular-rounded fragments of acidic plagioclase, acidic effusions, less often quartz porphyrites and an admixture of pyroclastic material – volcanic ash and larger fragments of acidic, less often than average volcanic glass – predominate in the Eifelian section. Undifferentiated Devonian-Carboniferous systems represented by volcanogenic-sedimentary deposits of the Tastau Formation (D<sub>3</sub>-C<sub>1</sub>ts), which agrees with a gradual transition lies on the sediments of the middle Devonian. The terrain is represented by monotonous, predominantly fine and

fine-grained tuffogenic and sedimentary rocks that have undergone secondary changes – silification, sericitization, and chloritization. The Carboniferous system is represented by the deposits of the Visean stage (C<sub>1v</sub>), developed in the Arganaty mountains. The lithological composition of the Visean deposits is quite diverse. In the lower horizons, psammitic rocks predominate: polymictic and tuffogenic sandstones. Conglomerate-breccia and fine-grained differences are of primary importance: siltstone, tuffogenic siltstone, tuffite. Up the section, the psammitic formations replaced by a pack of uniform silty carbonaceous-clay shales, among which in a small amount there are siltstone, siliceous-clay, carbonaceous-chlorite and mica schists. The total capacity of the Visean stage is up to 1100 m.

Cenozoic is represented by sandy-clay deposits in the composition of two Miocene suite: Aral and Pavlodar, as well as pale-colored loam and gravelite and forest of Pliocene age. They come to the surface in the central part of the area and exposed in separate areas in the south of it. The size of exposed areas does not exceed 2-5 km.

Quaternary formations are widely developed on flat areas. They subdivided into alluvial, lacustrine, deluvial-proluvial, takyr-salt bottom and aeolian deposits, the thickness of which varies from the first to 10-20 m.

*Intrusive formations.* Outcrops of intrusive rocks are represented by an insignificant area of quartz diorites, located in the southwestern part of the Arganaty mountains. The rocks of the vein facies – the veins and dikes of acid and medium composition – are much more widespread. An array of quartz diorites is located at the northwestern margin of the Arganaty mountains, 0.8 km northeast of an altitude of 433 m. The body of quartz diorite has a rounded shape, somewhat elongated from the southeast to the northwest. The size of the array is 250 x 150 m.

Hornfelsification rocks, similar to those described in the exocontact of quartz diorite massive are also noted in other areas, located mainly in the north-eastern part. The area of the largest of them reaches 16 km<sup>2</sup>. Hornfelsification of rocks can serve as an indication of the presence of an intrusive occurring at a shallow depth that has not yet been eroded. Intensive development of vein formations is an additional confirmation of this assumption. The presence here of unopened intrusion also confirmed by geophysical data. Quartz diorite massive is probably the apical part of the dome of an intrusive body that has not yet been exposed to erosion.

The presence of granitic pegmatites, granite-porphyre dykes and quartz porphyries among the gangue rocks encountered in the area, which are apparently derivatives of unopened intrusion, indicates its acidic granitoid composition. Of the rocks of the vein facies, dykes of medium composition are most common; acid dykes and quartz veins are less common. On a separate site revealed the veins of granite pegmatites. The following sequence of dykes introduction is planned for the district. The most ancient are, apparently, granite-porphyre and quartz porphyre, followed by the introduction of dykes of medium composition, and finally, granite pegmatites and quartz veins are formed [1].

Most of the described territory confined to the Tastau structural-formation zone (SFZ). Only the extreme, north-eastern part of the area, covered by Cenozoic formations, belongs to the Alakol structural-formation zone. The Tastau SFZ is separated from it by the regional Zhongar fault, traced 400 km from the Zhongar gates to the Shubartau mountains in the Northern Balkhash region.

The extensive development of Cenozoic sediments within the region under consideration does not allow deciphering the main Paleozoic structures with sufficient completeness. The geological data obtained as a result of the survey and editorial work of the region indicate that the Tastau SFZ during the Devonian and Lower Carboniferous was a deflection area, where continuous sedimentation occurred. Here, in the marine and coastal conditions, thick strata of siliceous pyroclastic and terrigenous rocks deposited.

The main linear folded structures formed after the deposition of the Visean stage. The upper horizons of the middle Carboniferous, which characterized by gentle platform-type brachis-folds, are sharply inconsistent with the lower mid- Carboniferous deposits. This indicates the average carbon age of the formation of linear folded structures of Tastau SFZ.

A sinclinorium is confined to the Tastau structural-formation zone within the region under consideration, the most submerged part of which is located on the site of the Arganaty-Arkharly mountains. Sinclinorium is a large structure, complicated by smaller syncline and anticline folds, which characterized by a steep fall of the wings, and vertical and overturned occurrences are often observed.

In the Kyskash mountains region, several syncline and anticline folds are noted. In the Arkharly mountains there are three syncline structures, the axes of which can be traced from the southern slopes of the mountains in the north-west and then in the latitude direction. The cores of syncline folds are composed of calcareous rocks, the wings and the anticlines that separate them are formed by shales, tuffs and tuffites. Along the strike of syncline structures, centricline closures associated with uplift of their hinges often observed. The axes of the folds are somewhat tilted to the south and southwest. The southwestern wings of the synclines fall to the northeast at an angle of 50-60°, while the northeastern wings have vertical or overturned beddings with a fall to the northeast at an angle of 80-85°.

Two syncline structures, the cores of which are made of calcareous rocks of the upper horizons of the upper sub-suite of the Tastau suite, are observed to the south of the Arganaty mountains. The axes of the synclines extend from the eastern border of the territory in question in the latitudinal direction; in the western part of the Arganaty mountains, they turn steeply to the south and north-west of the Kok-Donbuk hill, extend in a sub-latitudinal direction with a slight deviation to the south-west. There are also several cases of centricline closure of synclines associated with the undulation of hinges.

In the Arganaty mountains, between the faults that flank the regional Zhongar fault, a graben is formed, which is made up of intensively stratified Visean sediments. Breeds are collected here in steep folds, the fall of the wings of which is 60-80°. Two anticline folds are outlined, the cores of which are composed of sandstones and conglomerate-breccias of the lower horizons of the Visean stage. The wings of the anticlines and the adjacent synclines formed by the carbonaceous-shale of the upper horizons of the Visean layer. The axis of the folds extends in the northeastern direction.

Fault tectonics has a significant impact on the geological structure of the area. Two main fault systems are clearly distinguished: the northwest and northeast. The most widespread and clearly expressed faults of the north-west strike. This system includes the regional Zhongar Fault and several associated with it faults in the area of the Arganaty mountains. The Zhongar fault has an ancient foundation and long-term development. During the Devonian, Carboniferous, and Permian, it was the boundary of two structural-facies regions. In the zone of the Zhongar deep fault, which is the eastern geosuture fragments between the first and second core structures of the nuclear, large amplitude movements (up to 9 km) occurred, resulting in contact of the Silurian and upper horizons of the Lower Carboniferous. The Zhongar fault in the Arganaty mountains is fledged by small fracture faults along the latitudinal and northeastern directions, which by their significance are large faults limiting the Visean graben.

In the Remote sensing research process, the most promising areas were identified [2-5]. Ground prospecting routes, areal geophysical studies: magnetometric and electrometric mappings were carried out for the formulation of prospecting operations.

**Methods and Results.** Below are the results of ground geophysical works carried out on the research area. Magnetometric work was carried out at 9 local sites. Electrical exploration by the method of induced polarization (IP) carried out in an experimental method in the local area 4 (figure 1).

Magnetic exploration carried out using high-precision MM-61 proton magnetometers. Technical characteristics of the device allow to achieve high accuracy of shooting. Before starting the survey, a control point and a place for the installation of a magnetovariation station selected near the work site, one place for all sites. The choice was made based on the requirements: the absence of a high magnetic field gradient (less than 5 nT/10 meters) and sources of technical interference. The magnetometer MM-61, operating in automatic mode with a measurement interval of 60 seconds, was used as a magnetovariation station. Before starting work, the magnetometers synchronized in time to within one second. At the beginning and at the end of each route, control measurements made at the control point. When processing field observations, a correction for the variation of the magnetic field introduced. The results of specialized observations calculated relative to the control point.

Control observations were carried out by independent flights or various instruments. These flights were carried out in such a way as to ensure representative control over the number of measurements and the area. On the basis of the common and control measurements, the values of the mean square error calculated both for individual profiles and for the entire survey area according to the instruction (Magnetic Survey Instructions, 1981). The value of the mean square errors for the site was  $\pm 2,52$  nT, with the volume of control observations of 7%.

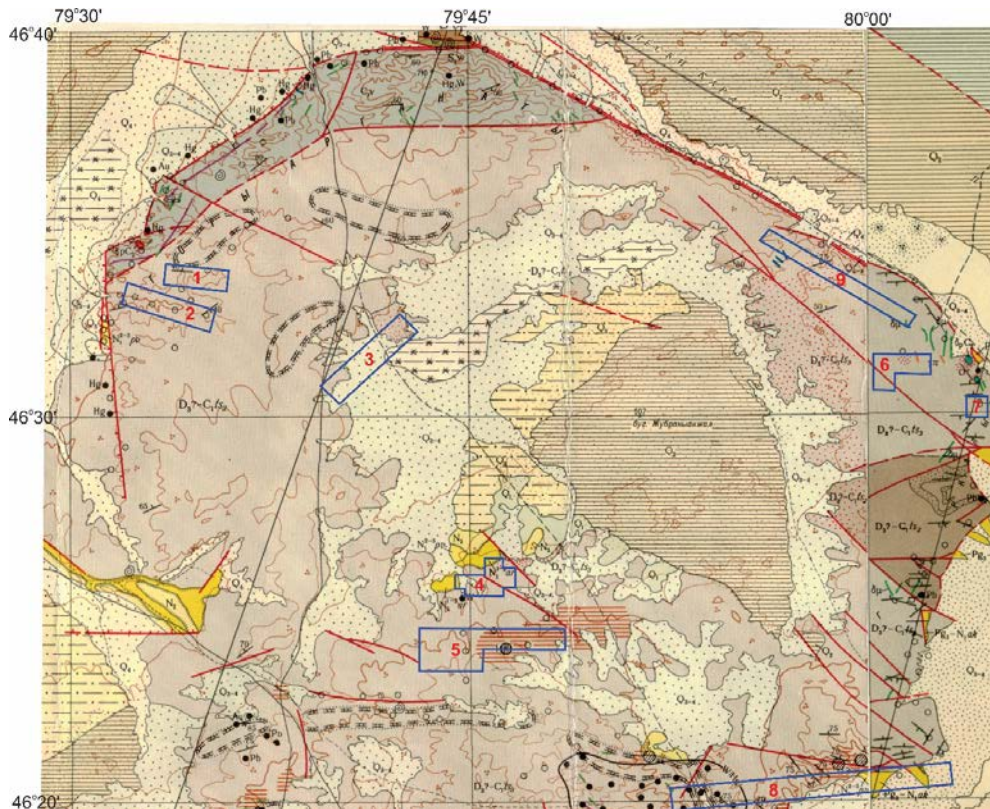

Figure 1 – Promising blocks of Arganaty district (East Balkhash) and their numbers

*Electrical exploration* work was carried out in the modification of the profile soundings of the induced polarization (IP) by the pol-dipole system in a separate designated area, where the anomaly was identified by magnetic prospecting (section No 4 of the profile 1600, 2000, 2400).

In the process of performing electrical exploration work, the following equipment of the IP system was used:

- 16 channel GDD IP Receiver Model GRx8-32 (16-channel receiver IP/Resistance manufactured by Canadian company Instrumentation GDD).
- GTT-30 Transmitter TX (Transmitter manufactured by Zonge Engineering and Research Organization, Inc., USA).
- Generator 15 kW manufactured by Zonge Engineering and Research Organization, Inc., USA.

The profile probing of the IP/Resistances carried out using a pole-dipole multi-electrode installation, including a supply dipole (AB) and a receiving line consisting of 14 receiving dipoles.

When performing profile soundings with a step of 40 m, the following electrode alignment was used:  $A = 40$  m,  $B = \text{infinity}$  (1000-3000 m), the distance between the measuring electrodes was 40 m, the distance between the nearest measuring and power electrodes was 40 m. Metal stakes, up to 100 cm long, stacked three to one ground in previously dug to a depth of 10-15 cm and poured with water. In the supply line was used a copper cable with a section of 4 mm covered with a vinyl sheath. The installed electrodes were filled with soil and poured on top with water while simultaneously mixing the soil. Non-polarizable ceramic electrodes with a solution of copper sulfate, whose own EMF did not exceed 2 mV, were used as receiving electrodes. The diameter of the cross-section of an insulated eight-core copper wire of the UTP 5e category in the receiving line was 8x1 mm. The actual values of contact resistances at the dipoles of the receiving line were within 6 kOhm. In general, they were distributed in the range of 1-4 kOhm.

The transmitter and receiver were synchronized according to the standard scheme for the equipment used on the basis of the transmitter signals recorded at one of the receiving dipoles. During the measurement, synchronization automatically maintained, as provided for in the hardware implementation. The actual shape of the rectangular pulses generated by the transmitter and the decay curves for each of the receiving dipoles monitored by the operator in the process of measuring the computer screen, which is

part of the registration system of the receiver. For the operator to enter data: profile, station, current, distance and pitch of the receiving and supply lines.

The polarizability value recorded by the receiver for each of the specified time windows, having the dimension [mV/V], recorded on each picket in the instrument file (date, time, profile, station, current, polarizability, natural polarization of the field, error rate, resistance). In this case, a weighted average calculated for all registration windows in the registration system processor, which was also recorded in the instrument file.

When performing sensing at each picket of the profile, a series of measurements carried out, consisting of 20-50 cycles of feeding and switching off polar opposite rectangular pulses. The duration of the current pulse was 2 seconds, the interval between current pulses, within which the IP potential decline recorded was 2 seconds. The process of stabilization of the measurement during many work cycles controlled visually on the screen of a laptop computer connected to the receiver of the IV. If necessary, if the process of stabilization of measurements in the cycle was not stable, which controlled by the absolute error values each receiving dipole in this series of cycles, the operator performed additional series of measurements at this point (station), which subsequently averaged during processing.

When developing electrical survey profiles, repeated measurements taken at the beginning, at the end and at each fifth point of the installation location of the dipole AB and 14 dipoles MN. Repeated measurements carried out at different current values ( $\pm 5\%$ ) in the supply line. Based on the convergence of the measurements, the quality of the survey regularly monitored.

Control measurements were made of 6.43 %, the error in polarizability was 2.1 % and the resistance of 1.9 %.

Processing of magnetic data divided into primary, carried out directly in the field and secondary processing. Primary processing of field observations consisted in introducing corrections for the variation of the geomagnetic field and calculating its values relative to the control point. Profile fragments worked on different days were combined for each profile and the site as a whole. In addition, in the process of field work, preliminary maps were prepared for the waste sections in the adopted profile/picket coordinate system.

Subsequent processing included the transition from the profile/picket coordinate system to the WGS 84 system, the construction and interpretation of a magnetic field map.

Processing of the results of electrical exploration began with pre-processing, which carried out directly in the field. The data obtained during each field day processed in the evening on the same day. The results of the pretreatment presented in the form of pseudosections of polarizability and resistance in a color graphic form.

The observed data for each profile for each picket, on which the repeated measurements taken, were averaged by the number of repeated measurements. Directly in the field, pseudosections built and preliminary data inversions carried out for each profile and for the entire section.

The final data processing was carried out after the completion of the field work and included the following steps:

- Constructing pseudosections of polarizability and resistances;
- Solving the inverse problem for geophysical profiles using successive approximations of models for polarizability and resistance (geophysical inversions 2D).

The pseudosections of polarizability and resistance obtained from electrical sounding data represent the express visualization of the information obtained during the survey. At the same time, the accuracy of mapping of geological objects depends both on the degree of severity of the objects themselves in geophysical fields, and on additional factors, including electrode effects, screen influence of low resistance zones. The main task in the analysis of data is to represent the objects being mapped while reducing the influence of these additional factors on this representation.

This problem solved using 2D inversions, first resistances and then polarizability. In fact, inversion is a modern implementation of the solution of the inverse problem in geophysics.

The solution of the inverse problem in inversion algorithms carried out using an iterative selection of a physical model based on the observed distribution of potentials in the receiving dipoles, taking into account the location of current sources. Previously, the lower half-space divided into a set of unit cells that approximate the physical parameters of the lower half-space. The inversion of polarizability carried out taking into account the distribution of resistances obtained from the results of inversion.

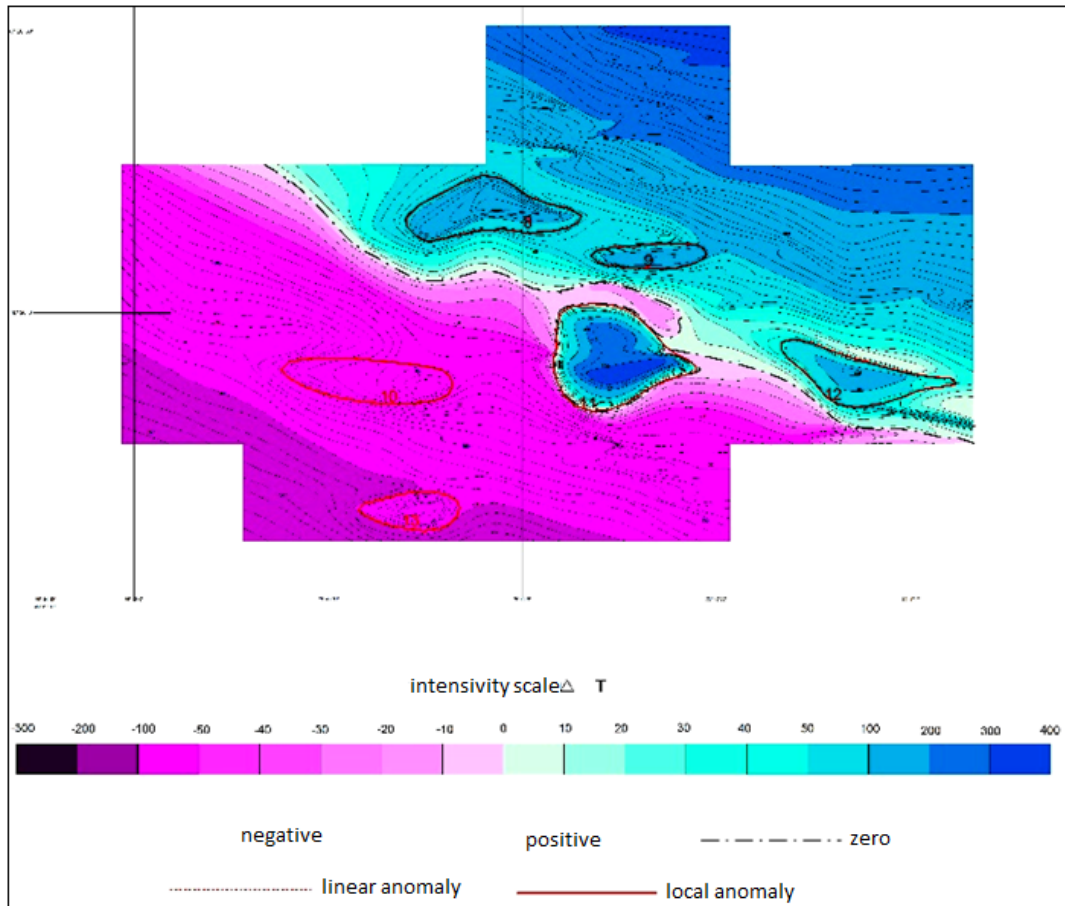

Figure 2 – Map of magnetic field anomalies of Block № 4 (normal field 57734 nT)

**Magnetic exploration.** Geophysical magnetic exploration work performed on selected sites with high quality and in full, provided by the task. The work performed allowed us to obtain a new, substantially refined, more detailed and informative version of the magnetic  $\Delta T$  maps of the 1:10 000 scale. Experimental electrical exploration work performed at section 4 in the area of the identified magnetic anomalies on individual profiles made it possible to construct pseudosections of primary data, 2D pseudosections inversions along these three profiles (figure 2). By qualitative interpretation of magnetic data, a selection of a number of local and linear anomalies carried out at sites.

**Conclusion.** Prospects for the Arganaty district sites, according to cosmogeological studies, are associated with the possibility of detecting endogenous metal mineralization (gold, copper, molybdenum, lead, zinc, tin, tungsten). This mineralization is most likely associated with the manifestation of intrusive magmatism, indicators of which (single stock, thermal impact areas on host rocks, magmatic ring structures, halos, and individual samples containing increased amounts of copper, lead, mercury, tungsten, and gold) are detected within the area. Here you can expect a wide range of the above-mentioned metallic minerals.

Ground-based geophysical works (magnetic exploration and experimental electrical exploration in the modification of core soundings caused by polarization (IP) using the pole-dipole system) were performed at 9 local sites based on remote sensing data and analysis of geological materials of the predecessors. As a result, in almost all areas, by analyzing the obtained magnetic maps, it is possible to identify important structural elements, relative to the occurrence of the Paleozoic basement rocks, various dyke formations (especially of medium composition) giving distinct positive anomalies.

Interesting data obtained at site No 4, where it was possible to establish a contact of the intrusion buried below the loose sediments of presumably medium composition with the Devonian-Carboniferous volcanogenic-sedimentary rocks of the Tastau formation. At the same time, in both the endo- and exocontacts, by the presence of local magnetic anomalies and anomalies of induced polarization (IP),

areas allegedly enriched with sulfide mineralization identified. It recommended to drilling prospecting wells.

**Acknowledgement.** The work carried out within the program-targeted financing theme of the Republic of Kazakhstan 2018/BR05233713 “Integrated geological study of the subsurface for the development of the resource base and new sources of ore raw materials in Kazakhstan”.

Ә. Б. Байбатша<sup>1</sup>, А. Мушинский<sup>2</sup>

<sup>1</sup>Satbayev University, Алматы, Қазақстан;

<sup>2</sup>Адам Мицкевич атындағы университеті, Познань, Польша

### АРҒАНАТЫ АУДАНЫ БОЛЖАМДЫҚ БӨЛКШЕЛЕРІНІҢ ГЕОЛОГИЯЛЫҚ-ГЕОФИЗИКАЛЫҚ ІЗДЕУ БЕЛГІЛЕРІ (ШЫҒЫС БАЛҚАШМАҢЫ)

**Аннотация.** Зерттелген алаң Шығыс Балқашмаңында, Алматы облысы Алакөл ауданының аумағында орналасқан. Алаңның бедері жазық, кей жерлерінде шағын төбелер бар. Алаңның үлкен бөлігінде қырқалар және құм төмпелері-шұңқырлары орналасқан, олар өскен шөптер тамырымен бекітілген, кейде бұта өсімдіктер де кездеседі. Зерделенген аумақтың геологиялық құрылысындағы ең көне жаралымдарға силур жүйесінің түзілімдері жатады, олар венлок легінің түзілімдерінен тұрады. Бұл түзілімдер Арғанаты тауының солтүстік шалғайында өңірлік Жоңғар жарылымы зонасындағы шағын тектоникалық блоқты құрайды. Ені 300-400 м және ұзындығы 15 км болатын силур таужыныстарының ашылымдары ендік созылымды жарылымдармен шектеліп, олар солтүстігінде ортаңғы девоннан, ал оңтүстігінде серпухов-ортаңғы карбон жаралымдарынан ажыратылады. Интрузиялық таужыныстар ашылымдары ауданы бойынша шағын кварцты диориттер денелерінен тұрады, олар Арғанаты тауының оңтүстік-батысы бөлігінде орналасқан. Желі фациясының таужыныстары айтарлықтай кең таралған, оларға қышқылды және орташа құрамды желілер мен дайкалар жатады. Қарастырылған ауданның қалыптасуы палеозой плюмінің әрекетімен байланысты Жоңғар-Балқаш ойысының ішкі бөлігінде орналасқан және Қазақстанның бірінші сақина құрылымы ауқымында болып табылады.

Арғанаты алаңының перспективалары эндогендік металдар (алтын, мыс, молибден, қорғасын, мырыш, қалайы, вольфрам) рудалануларын анықтау ықтималдығымен байланысты. Бұл рудалану ең алдымен интрузиялық магматизм білінімдерімен байланысты, олардың белгілері (жекелеген штоктар, сыйыстырушы таужыныстарға термалық ықпал ету бөлікшелері, магматогендік сақина құрылымдар, құрамында жоғары мөлшерде мыс, қорғасын, сынап, вольфрам және алтын бар ореолдар мен жекелеген сынамалар) зерттелген алаң ауқымында анықталған. Мұнда жоғарыда аталған металдар пайдалы қазбаларының кең спектрін күтуге болады.

Дистанциялық космогеологиялық зерттеулер нәтижесінде ең перспективалы екі бөлікше анықталған, осы жерлерде жербетілік геофизикалық зерттеулер магнитометриялық және электрбарлау әдістерімен жүргізілген. Магнитометриялық жұмыстар 9 шектеулі бөлікшеде жүргізілді. Электрбарлау жұмыстары мәжбүрлі поляризация (МП) әдісімен шектеулі 4-бөлікшеде тәжірибелік-әдістемелік нұсқада жүргізілген. Электрбарлау жұмыстары бастапқы деректердің псевдоқималарын тұрғызуға мүмкіндік берді, осылайша алынған үш кескін бойынша 2D инверсиясының псевдоқималары жасалды.

Зондылау жүргізген кезде кескіннің әр пикетінде өлшеулер легі орындалған, әр лек әртүрлі полусті тік бұрышты импульстерді берудің және сөндірудің 20-50 циклінен тұрады. Ток импульсінің ұзақтығы 2 секундты құрайды, ал ауқымында МП потенциалының қайту процесін тіркеу жүргізілген интервал да 2 секунд. Көптеген жұмыстық циклдер ағымындағы өлшеу процесінің тұрақталуы қолға алып жүретін компьютердің экранында көзмөлшермен қадағаланған, ал компьютер МП ресиверімен (қабылдағышымен) қосылған. Қажет болған кезде, егер циклдегі өлшеулердің тұрақталу процесі орнықты болмағанда, ол циклдердің берілген легінде әрбір қабылданатын диполь бойынша абсолют қателіктердің шамалары бойынша қадағаланған. Оператор берілген нүктеде (пикетте) өлшеулердің қосымша лектерін орындаған, ары қарай өңдеу процесінде бұл өлшеулердің орташа мәні анықталған.

Тәжірибелік электрбарлау жұмыстарын интерпретациялау процесінде үйектелудің және байқалатын кедергінің псевдоқималары тұрғызылған, сонымен қатар олардың 2D инверсияларының псевдоқималары да тұрғызылды. Байқалғандай, аудандағы үйектелгіштіктің таралуы ықтимал өнімді қатқабатта сульфидтердің аялық таралуының қосынды әсеріне байланысты болуы мүмкін. Сульфид минералдану зоналары палеозой бетінен бірнеше метр тереңдікте жайғасқан жерлерде айқын білінетін МП әсері байқалады, мұндай жағдайда жоғары үйектелгіш зоналар анық білінеді. Сульфид минералдану зонасы үзік-үзік сипатқа ие болғанда және тереңде орналасқан жағдайларда бейконтраст аномалиялар байқалады. Бұл аномалияларды сульфидтердің

жекелеген ұсақ шоғырлануларының таралуына байланысты туындаған аномал әсерлерінен ажырату қиын болады. Зоналар әдетте үйектелгіштік аномалияларының жоғарғы бөлігімен сәйкестендіріледі.

Кедергілер (рк псевдоқималары) деректері бойынша, кедергілердің өзгеруі мезозой-кайнозой қатқабаты қалыңдығының артуына байланысты болады, оның артуымен кедергі бойынша көрсеткіштер де өзгереді. Электр өрістері таралуының жалпы көрінісі, магнит өрісіндегі сияқты, өрістердің орнықты градиентін көрсетеді. Өрістердің қарқындылығы бөлікшенің солтүстік бөлігінде артады.

Магнитбарлау жұмыстары жоғары дәлдікті ММ-61 протондық магнитометрді пайдалану арқылы жүргізілді. Құралдың техникалық сипаттамасы түсірудің жоғары дәлдігіне қол жеткізуге әкеледі. Жұмысты орындау магнит өрісінің 1:10 000 масштабты  $\Delta T$  картасының жаңа, біршама дәл және ақпаратты нұсқасын алуға мүмкіндік берді. Магнитбарлау деректерін сапалы интерпретациялау жолымен бөлікшелерде бірқатар шектеулі және сызықтық аномалиялар бөліктері анықталды. Магнитбарлау деректері бойынша ең қызығушылыққа 4-бөлікше ие. Бөлікшенің магнит өрісі екіге бөлінеді – ССШ және ООБ. Осы бөліктердің шекарасы бойынша нөлдік изосызық өтеді. Өрістің ССШ бөлігі айқын оң мәнді (градиенті  $\Delta T$  250 нТл мәні шамасына дейін). ООБ бөлігі бішама теріс градиентті  $\Delta T$  -250 нТл мәніне дейін. Ең алдымен, оң мәнді өріс (МП электрбарлау кескіндерінің деректері бойынша сияқты) төрттік тысы астында орташа құрамды интрузия массиві шығуына, оның эндо- және экзожапсарындағы метасоматоздық өзгерген таужыныстар зоналары болуына байланысты.

**Түйін сөздер:** магнитті барлау, электр барлау, аномалия, жерленген гранитоид, сульфидті минералдану, барлау бұрғылау.

**А. Б. Байбатша<sup>1</sup>, А. Мушинский<sup>2</sup>**

<sup>1</sup>Satbayev University, Алматы, Қазақстан;

<sup>2</sup>Университет Адама Мицкевича, Познань, Польша

#### **ГЕОЛОГО-ГЕОФИЗИЧЕСКИЕ ПОИСКОВЫЕ ПРИЗНАКИ ПРОГНОЗНЫХ УЧАСТКОВ РАЙОНА АРГАНАТЫ (ВОСТОЧНОЕ ПРИБАЛХАШЬЕ)**

**Аннотация.** Исследованная площадь расположена в Восточном Прибалхашье, на территории Алакольского района Алматинской области. Рельеф площади равнинный, местами слабо холмистый. Большая часть площади занята грядовыми и бугристо-лунковыми песками, закрепленными травянистой, иногда кустарниковой растительностью. В геологическом строении изученной территории самыми древними являются отложения силурийской системы, которая представлена отложениями венлокской серии, слагающими небольшой тектонический блок в зоне регионального Жонгарского разлома на северной окраине гор Арганаты. Выходы силурийских пород шириной 300-400 м и длиной 15 км ограничены разломами широтного простирания, которые отделяют их от среднего девона на севере и серпухова-среднего карбона на юге. Выходы интрузивных пород представлены незначительным по площади массивом кварцевых диоритов, расположенным в юго-западной части гор Арганаты. Значительно более широко распространены породы жильной фации – жилы и дайки кислого и среднего состава. Рассматриваемый район приурочен к внутренней части Жонгаро-Балхашского прогиба, формирование которого связан с деятельностью палеозойского плюма и представляет собой первую кольцевую структуру Казахстана

Перспективы площади Арганаты связаны с возможностью обнаружения эндогенного металлического оруденения (золото, медь, молибден, свинец, цинк, олово, вольфрам). Это оруденение, вероятнее всего, связано с проявлением интрузивного магматизма, признаки которого (единичный шток, участки термического воздействия на вмещающие породы, магматогенные кольцевые структуры, ореолы и отдельные пробы, содержащие повышенные количества меди, свинца, ртути, вольфрама и золота) обнаруживаются в пределах площади. Здесь можно ожидать широкий спектр вышеупомянутых металлических полезных ископаемых.

В результате дистанционных космогеологических исследований были выделены наиболее перспективные участки, на которых проведены наземные геофизические исследования двумя методами. Магнитометрические работы были проведены на 9 локальных участках. Электроразведочные работы методом вызванной поляризации (ВП) были проведены в опытно-методическом варианте на локальном участке 4. Электроразведочные работы дали возможность построить псевдоразрезы первичных данных, псевдоразрезы 2D инверсии по этим трем профилям.

При выполнении зондирования на каждом пикете профиля выполнялась серия замеров, состоящая из 20-50 циклов подачи и выключения разнополярных прямоугольных импульсов. Длительность токового импульса составляла 2 секунды, интервал между импульсами тока, в пределах которого осуществлялась регистрация процесса спада потенциала ВП составляла 2 секунды. Процесс стабилизации замера в течение множества рабочих циклов контролировался визуально на экране переносного компьютера, соединенного с

ресивером (приемником) ВП. При необходимости, если процесс стабилизации замеров в цикле не был устойчивым, что контролировалось по величинам абсолютных погрешностей по каждому приемному диполю в данной серии циклов, оператором выполнялись дополнительные серии замеров на данной точке (пикете), которые в дальнейшем осреднялись в процессе обработки.

В процессе интерпретации опытных электроразведочных работ были построены псевдоразрезы поляризуемости и кажущегося сопротивления, а также псевдоразрезы их 2D инверсий. Отмечено, что распределение поляризуемости в районе может быть обусловлено суммарным влиянием фонового распределения сульфидов в возможной продуктивной толще. Там, где зоны сульфидной минерализации залегают на глубине нескольких метров от поверхности палеозоя, наблюдается ярко выраженный эффект ВП, который контрастно выделяет зоны с повышенной поляризуемостью. В случаях, когда зона сульфидной минерализации имеет прерывистый характер и находится на глубине, наблюдаются неконтрастные аномалии, которые трудно отделить от аномального эффекта, обусловленного распределением отдельных мелких скоплений сульфидов. Зоны, как правило, коррелируются с верхней частью аномалий поляризуемости.

По данным сопротивления (псевдоразрезы  $\rho_k$ ), изменения сопротивления зависят от увеличения мощности мезозой-кайнозойской толщи, с ее увеличением растет и показания по сопротивлению. Общая картина распределения электрических полей, как и магнитного поля, показывает устойчивый градиент полей с увеличением их интенсивности в северной части участка.

Магниторазведочные работы осуществлялись с использованием высокоточных протонных магнитометров ММ-61. Технические характеристики прибора позволяют достичь высокой точности съемки. Выполненные работы позволили получить новый, существенно уточненный, более детальный и информативный вариант карт магнитного поля  $\Delta T$  масштаба 1:10 000. Путем качественной интерпретации магниторазведочных данных, проведено выделение на участках ряда локальных и линейных аномалий. По данным магниторазведочных работ наиболее интересные данные получены на участке 4. Магнитное поле участка разбивается на две части – ССВ и ЮЮЗ. По границе этих участков проходит нулевая изолиния. ССВ часть поля отчетливо положительна (с градиентом до  $\Delta T$  250 нТл). ЮЮЗ часть относительно отрицательна с градиентом до  $\Delta T$  -250 нТл. Скорее всего, положительное поле (как и по данным электроразведочных профилей ВП) связано с выходами под четвертичным чехлом интрузивного массива среднего состава, с зонами метасоматически измененных пород как в эндо-, так и в экзоконтактах.

**Ключевые слова:** магнитная разведка, электроразведка, аномалия, погребенный гранитоид, сульфидная минерализация, поисковое бурение.

#### Information about the authors:

Baibatsha Adilkhan Bekdildaevich, Doctor of Geological and Mineral. sciences, professor of the department “Geological survey, searches and exploration of Mineral deposits” of the Kazakh National Research Technical University named after K. I. Satpayev, Almaty, Kazakhstan; baibatsha48@mail.ru; <https://orcid.org/0000-0002-9521-7872>

Muszyński, Andrzej, Doctor hab., professor, Institute of Geology Adam Mickiewicz University; [anmu@amu.edu.pl](mailto:anmu@amu.edu.pl); <http://orcid.org/0000-0002-9746-0278>

#### REFERENCES

- [1] Baibatsha A.B., Mamanov E.Zh., Ibraev K.O., Tikembaev B.A. (2019) Geological structure and geodynamics of the Arganata area and its ore-controlling prerequisites / Bulletin of KazNRTU. N 3, P. 13-19 (in Russ.).
- [2] Baibatsha A. (2017) Relationship of Paleozooids and Mineral Deposits of Kazakhstan with the Paleozoic Superplume. 17th International Multidisciplinary Scientific GeoConference SGEM, 29 June-5 July 2017, Albena, Bulgaria. Vol. 17, Issue 11. P. 479-486.
- [3] Baibatsha A.B. (2017) Paleozoic superplume in the formation of the geological structures of the earth with related metal deposits. Proceedings of XXXIV International Conference. Miass, 4-9 August 2017. P. 28-30. ISBN 978-5-905049-21-7
- [4] Baibatsha A.B. (2018) Innovative technology forecasting minerals. ISBN 978-601-7962-05-0. Almaty, 524 p. ISBN: 978-601-7962-05-0 (in Russ.).
- [5] Baibatsha A.B., Peng Suping, Satibekova S.B. (2019) Estimation of the physical-mechanical properties of the rocks on the degree of coal metamorphism / NEWS of the Academy of Sciences of the Republic of Kazakhstan. Series of Geology and Technical Sciences. Vol. 1, N 433 (2019), P. 187-194. <http://www.geolog-technical.kz/images/pdf/g20191/187-194.pdf> <http://dx.doi.org/10.32014/2019.2518-170X.23>.

**NEWS**

OF THE NATIONAL ACADEMY OF SCIENCES OF THE REPUBLIC OF KAZAKHSTAN

**SERIES OF GEOLOGY AND TECHNICAL SCIENCES**

ISSN 2224-5278

Volume 2, Number 440 (2020), 40 – 47

<https://doi.org/10.32014/2020.2518-170X.29>

UDC 553.981/982.041(1/9)

**A. B. Bigaraev, E. S. Mussina**

Satpaev Institute of Geological Sciences at the Satbayev University, Almaty, Kazakhstan.

E-mail: [anuarbek\\_bi@mail.ru](mailto:anuarbek_bi@mail.ru), [musina.63@mail.ru](mailto:musina.63@mail.ru)

**STATE OF STUDY, GEOLOGICAL STRUCTURE  
AND OIL-AND-GAS-BEARING CAPACITY  
OF THE NORTH KAZAKHSTAN SEDIMENTARY BASIN**

**Abstract.** The North Kazakhstan sedimentary basin has great potential for identifying new hydrocarbon deposits. The geological structure of the territory under consideration includes the formation of pre-Cambrian, Paleozoic, Mesozoic and Cenozoic. They are divided into 3 different complexes: strongly dislocated and significantly metamorphosed formations of the Precambrian and lower Palaeozoic, moderately dislocated sediments of the middle-upper Palaeozoic and not dislocated - Jurassic, Cretaceous and Cenozoic ages. The first complex forms a crystal base, broken through by granitoid intrusions. The second complex forms an intermediate quasi-platform floor. The deposits of the third complex are part of the platform cover, 1200-1600 m thick. Starting from the Jurassic and downwards, the horst-graben-riftogenic structures are showing up in the lower Mesozoic and upper Paleozoic, which favours the area's oil and gas potential.

The current paper reflects on the state of study and features of the geological structure and tectonics of the North-Kazakhstan sedimentary basin, basing on generalization and analysis of all available geological and geophysical materials, and considers the oil and gas content and the problem of further studies of the basin.

Therefore, it is desired to conduct a regional 2D-seismic survey to the north, in the area of the Bugrov, Vinogradov and Voskresensk moulds, detected as per data acquired during the magnetoexploration.

**Key words:** sedimentary basin, rift structure, prospects of oil and gas bearing capacity, Jurassic deposits, quasiplatform complex.

The North-Kazakhstan sedimentary basin with the area of 55,000 km<sup>2</sup> is attributed to the North-Kazakhstan monocline, occupying the southern periphery of the vast West Siberian oil-and-gas-bearing mega-basin. The North-Kazakhstan basin has a clear tectonic border in the south, where it is limited by the Kokshetau massif. The northern limits coincide with the state border; in the west it gradually passes to the North-Torgay basin, behind a conditional border of the 66° Easting and coincides with the border between the Kostanay and North-Kazakhstan regions, administratively belonging to the latter (figure 1).

Geophysical studies of the North-Kazakhstan basin began in 1937, when, during magnetometric surveys, a number of magnetic anomalies were revealed, subsequently becoming an object for the reflection method (RM) and the correlation refraction method (CRM) of the seismic surveys.

During 1937-1943, based on the seismic and magnet surveys data, the West Siberian expedition revealed local uplifts of Asanov, Tokushin, Yakovlev, Ryavkin and Oktyabrsk. Three wells were drilled at the Asanov uplift in 1940-43 and 13 wells at other uplifts during 1952-54. All wells opened Paleozoic deposits and were stopped therein at depths 1200-1880 m. No signs of possible oil and gas were detected.

Early 1950s, the Omsk geophysical team carried out RM & CRM geophysical research to study the Meso-Cenozoic sedimentary cover and Paleozoic deposits on the Asanov-Oktyabrsk group of structures, and in 1951 along the regional railway route Petropavlovsk - Novosibirsk.

Since 1959, the North-Kazakhstan geophysical team carried out the CRM seismic surveys on regional profiles. In northern profile sections, the RM seismic survey was implemented in small amount. Profiles are mainly orientated submeridially.

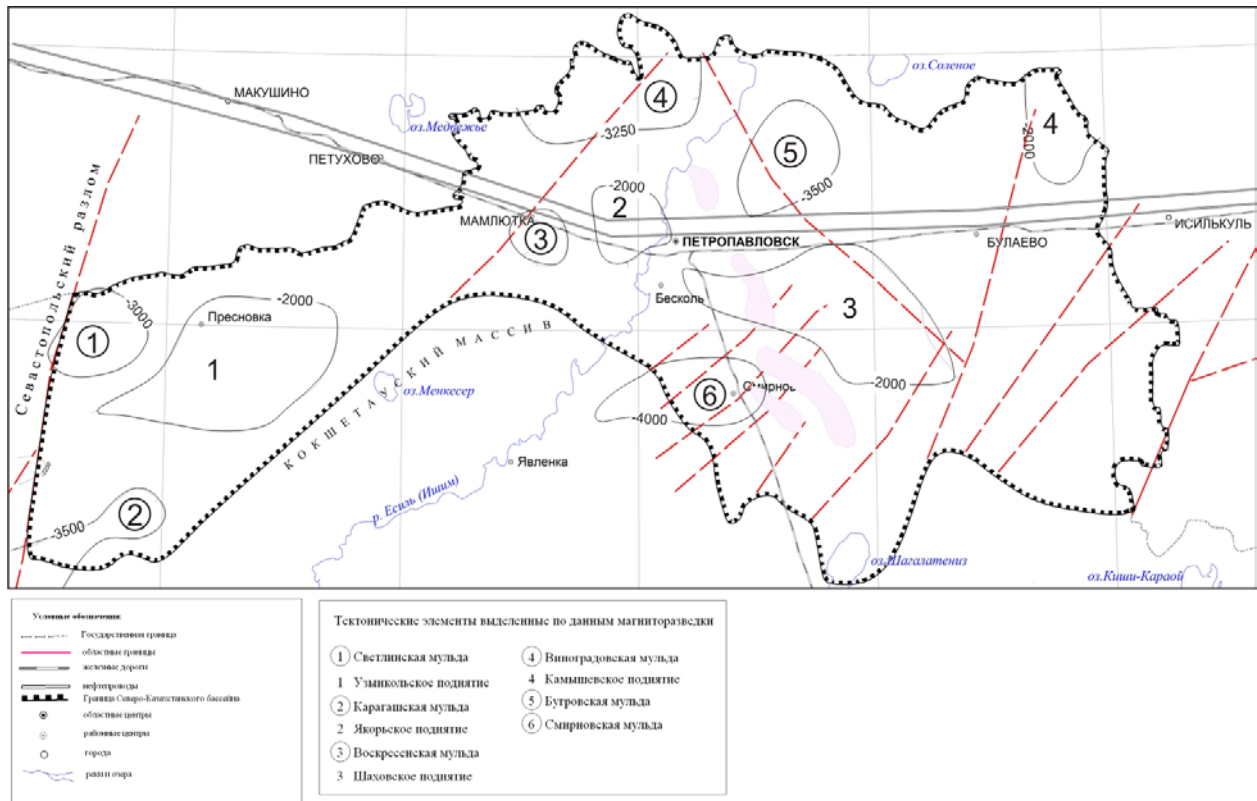

Figure 1 – The map of tectonic zoning

It was established, that stratum of the Meso-Cenozoic cover increases gradually from south to north and northeast, and the depths of the Palaeozoic surface from the first hundreds of meters on the southern profile flanks up to 1500-1600 m on the border with Russia. The image of the areal geological structure became clear. The main refractive boundary was traced: the eroded surface of Palaeozoic deposits and some less significant boundaries in the Mesozoic strata.

Information on internal structure of Paleozoic deposits is practically absent but the boundary velocities allow seeing changes in the Paleozoic surface lithology.

Although no oil and gas prospective objects were found and no recommendations for further exploration were given, the oil and gas search within the North-Kazakhstan monocline continues to this day. Later on, the Tevriz, Taytym, Prirakhtov fields were discovered in the territory of Russia, in the Mesozoic deposits, 250-300 km north of Petropavlovsk, and 450 km to northeast, and the fields of Maloich, Verkh-Tar, Urman, Kalinovin Paleozoic deposits.

The study of the North-Kazakhstan basin by deep drilling was conducted in two stages. Three wells were drilled at the Asanov uplift in 1940-43, 13 wells at other uplifts during 1952-54. All wells opened Paleozoic deposits and were stopped therein, at depths 1200-1880 m.

Based on results of the drilling operations, no oil and gas signs were identified in the well sections. This amount of drilling work is not sufficient to assess the oil and gas potential of the territory of 55,000 km<sup>2</sup>, but it makes a significant contribution to the study of the geological structure of the basin. According to the data, acquired in the area, it was established the block structure of the paleozoic and the foundation and the presence of possible riftogenic floor, beginning from the Jurassic and covering the whole of the upper Paleozoic (figure 2) [7].

The geological structure of the territory under consideration includes the formation of pre-Cambrian, Paleozoic, Mesozoic and Cenozoic. They are divided into 3 different complexes: strongly dislocated and significantly metamorphosed formations of the Precambrian and lower Palaeozoic, moderately dislocated sediments of the middle-upper Palaeozoic and not dislocated - Jurassic, Cretaceous and Cenozoic ages. The first complex forms a crystal base, broken through by granitoid intrusions. The second complex forms an intermediate quasi-platform floor. The deposits of the third complex are part of the platform cover, 1200-1600 m thick

Wells no. 2, 3 were drilled on the Asanov area, 4 wells on the Yakovlev area:

Well no.	Depth	Age, tier	Discovered rocks
the Asanov area			
1Ya	From the bottom hole at 1028m down to 1194m	the lower Cretaceous, below the Valanginian layer	red-coloured sand-clay-carbonate deposits of Paleozoic (Permian?)
2Ya	From the bottom hole of 1080m, the interval of 1050-1075 m	upper Jurassic	undivided Paleozoic, possibly the lower Paleozoic.
3Ya	1200 -1135 m	below deposits of the upper Jurassic	the gray-coloured clay-carbonate deposits of lower Carboniferous
6Ya	1110 - 1200m	Below the chalk bottom	bottom carbon?

Well no.	Depth	Age, tier	Discovered rocks
the Ryavkin area			
1R	1485 - 1578.8m	Below lower-middle Jurassic	terrigenous-carbonate deposits of C <sub>1v1</sub>
3R	1465 - 1880.4	below the lower Jurassic the lower Viséan layer of the lower Carboniferous	terrigenous-carbonate deposits
4R	Bottom hole of 1559m	under upper Jurassic sediments	lower Carboniferous sediments
5R	1362 - 1803.6	below the middle Jurassic	lower carbon deposits
The Oktyabrsk area			
1O	1299 - 1331m	Below the K <sub>1v</sub> sediments	penetrated the basement rocks represented by the lower Paleozoic granodiorites
2O	1360-1376 m	below the lower Cretaceous	granites of the lower Paleozoic age
3O	1387-1395 m	below the upper Jurassic	porphyrites of the lower Palaeozoic

The foundation is composed of pre-Cambrian and lower Palaeozoic formations. The Precambrian (Rifféan-Vendian) formations compose separate blocks of the foundation, opened by single wells and represented by gneisses, amphibolites, quartzites, and porphyritoids. The metamorphic rock strata were conditionally attributed to the lower Paleozoic.

Formations of the lower Palaeozoic have a wide development and in the south reach to daylight surface. These are mainly rhythmic alternations of argillites, siltstones, sandstones with limestones, tuffaceous stones, tuffs and effusives of the main and middle composition. On the basis of the brachiopod fauna, the thickness is attributed to the lower-middle Ordovician. Cambrian formations composed by acidic effusives, their tuffs with interlayers of conglomerates, sandstones and siltstones, are exposed in the north and northwest of the Kokshetau massif and were discovered along its periphery. At the N-42-Xtrapezoid (the Asanov area), shales were opened in deep wells, broken through by diabase dikes: due to their complex dislocation and high degree of metamorphism attributed to the lower Paleozoic age. At the Petukhov area (N-42-IX), the wells penetrated brown metamorphosed sandstones with interlayers of red-brown claystones, also conditionally attributed to this age. *The quasiplatform complex is composed of mid-upper Devonian, Carboniferous and Permian deposits.*

The mid-upper Devonian sediments with erosion lie on the underlying lower Paleozoic rocks and intrusive formations. In moulds of the Kokshetau Uplift, the middle-upper Devonian section is represented by red, raspberry conglomerates, sandstones, siltstones and argillites. Moreover, coarse-grained rocks occur at the bottom of the section. The thickness of red-coloured sediments is 400 m; probably, a similar section and the same thickness of these sediments can be expected in the Petropavlovsk district. Sediments, attributed to the lower Carboniferous, bear the central part of the superimposed mould and were penetrated by deep drilling wells in the areas of Yakovlev, Ryavkin and Gankin. Their most representative sections, confirmed by faunas of brachiopods and bryozoans, were noted at the Ryavkin area (wells 1R, 3R, 4R and 5R) (figure 2). The lower boundary of these deposits has not been opened by wells. Within the Ryavkin Uplift (N-42-XI), the deposits of the lower Carboniferous are represented by grey, dark grey, greenish-grey argillites, siltstones, polymict sandstones and limestones alternating with each other. Single thin interlayers of conglomerates, tuffaceous sandstones and tuffs were encountered. The

rocks contain small plant remainders, leather coats, imprints and fragments of the brachiopod fauna, bryozoans and fine aggregate pyrite. Falling angles of rocks vary from 5 to 17 degrees. By fauna these breeds are attributed to the Viséan. The opened thickness of these sediments within the limits of superimposed mould is 442 m, the maximum thickness probably does not exceed 600-700 m. The Permian deposits include rocks drilled by deep wells at the Yakovlev uplift. Though the drilling was not performed till the end. The Perm deposits are covered by the lower Chalk sediments and are the central part of the superimposed mould.

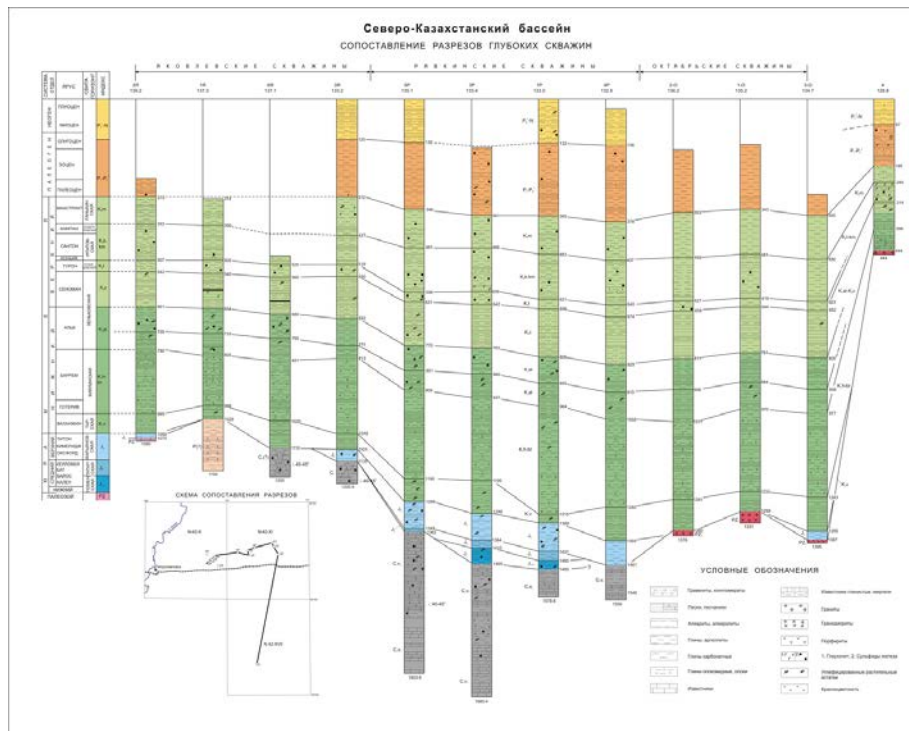

Figure 2 – Comparison of deep well sections

They are represented by brown, reddish-brown, sometimes coloured mudstones, alternating with less thick siltstones and light-gray, grayish-pink and red-brown sandstones; the stratum dip is up to 15°. Paleontologically, these sediments are not characterized and were attributed to the Permian conditionally, on the basis of comparison with similar formations in the southern regions of Northern Kazakhstan. Their mid-late-Carbon age is not excluded. The penetrated thickness of the Permian sediments at the Yakovlev area is 166 m (1Ya), the maximal one may go to 500-600 m.

*The platform cover is composed of Mesozoic-Cenozoic sediments.* Jurassic formations in the Petropavlovsk district, like on the entire northern slope of the Kazakh Shield, have limited distribution. Their accumulation took place mainly in the pre-Jurassic erosion trenches and paleovalleys of near-meridional orientation. The Jurassic watersheds were areas of erosion and encrustation. Formations of the Jurassic age are of the following tiers: the Tyumen (lower-middle Jurassic, including the Bajocian), Toarcian (Bathonian-Callovian) and Marianov (upper Jurassic). Their distribution is clearly conditioned by the complex formation pattern. The most ancient sediments ( $J_{1-2}$ ) compose the narrow Talwegian parts of paleovalleys, while the final sedimentation of the upper Jurassic clayey strata are more spread, usually extending beyond the margins of sea cliffs.

*The lower-middle Jurassic (Tyumensuite  $J_{1-2}$ ).* Slightly thick formations (25-40 m) were identified by drilling in the Ryavkin area, where they lie on the eroded surface of the ViséanCarbon formations. The section is dominated by grey to black claystones, often carbonaceous, silty and sandy. The rocks contain abundant plant detritus, small lenses of shiny brown coal and pyrite concretions. Among mudstones, there are interlayers of grey, light-grey and often clayey siltstones and polymict sandstones.

*The middle Jurassic (Tatarian suite  $J_{3b-kl}$ ).* The suite formations were identified only in the Ryavkin and Gankinareas, where they overlap the underlying sediments of the Tyumen suite or lie with erosion on the foundation rocks. The suite is represented by the alternation of colourful clays, non-layered siltstones,

siltstones with subordinate layers of gray, greenish-grey sandstones and siltstones, cemented with carbonate-clay material. The suite sediments were not characterized paleontologically, and their classification as middle Jurassic is conditioned by the position in the section between strata with the established age. The thickness of sediments in the wells does not exceed 29 m.

*The upper Jurassic (Marianov suite J<sub>3</sub>).* The suite formation with a maximum thickness of 103 m was found in the Yakovlev, Ryavkin, Oktyabrsk and Gankin areas. They are found conformable to the Tatarian rocks, or on deeply eroded foundation formations. The lower part of the section is dominated by grayish, grayish-green argillites, siltstones with glauconite grains, inclusions of pyrite, plant detritus, brachiopods, pelecypods, ammonites, belemnites, scales and fish remains. Above, gray and dark-grey unevenly calcareous and siderized argillites lie with subordinate layers of gray siltstones and fine-grained sandstones, less often with dark-gray clayed limestone. The age of the suite was defined by the fauna as a Cimmerian and even

Valanginian. Therefore, some researchers raise the upper age limit of the Marianov suite to the lower levels of the early Cretaceous (J<sub>3</sub>-K<sub>1</sub>). The Cretaceous system is represented by all times.

*The Valanginian tier of the lower Cretaceous* is represented by the Tar suite (K<sub>1v</sub>). They were discovered in the Yakovlev, Ryavkin, Oktyabrsk and Gankin areas and are located either on deposits of the upper Jurassic or on rocks of the folded foundation. The suite 106-113 m thick is represented in all sections by predominantly fine-grained light-gray and grey, unevenly calcareous sands. Interlayers of greenish-gray clays and siltstones are of subordinate importance. Inclusions of pyrite, glauconite, charred plant remain and semi-glossy coal interlayers are noted in composition of the rocks. There are layers of gravelites and inequigranulars and stones noted in some sections at the suite base.

*The Hauterivian-Barreme (Kiyala suite, K<sub>1h-b</sub>).* The Kiyala suite formation is eroded on the foundation rocks, or without interruption on the Valanginian rocks. The suite is represented by a thickness of coloured clays, alternating with subordinate interlayers of sand, sandstones and siltstones. The thickness of units and interlayers of clays varies from 2-4 to 20-30 m. In the south direction, the role of sand material in the section increases. In the upper part of the section, the clays are painted in red colours of different tints, and in the lower part of the section, the greenish-grey and green colours prevail. They are usually argillite-like, in some places of the siderized montmorillonite-kaolin composition. Sands and sandstones are grey, greenish-gray, feldspar-quartz, with admixture of glauconite. The suite thickness varies from 60 to 360 m.

*The Aptian-Cenomanian (K<sub>1a</sub>-K<sub>2c</sub>, Lenkov suite).* The suite formations are widespread, lying without a visible break on rocks of the Kiyala suite and in some areas on foundation rocks. Its thicknesses increase from southwest to northeast from 20-50 to 350-400 m. The most complete sections of the Lenkov suite were observed in the northeast of the territory, where it is discerned by composition into three strata, which some researchers individuate as independent suits. The lower strata are characterized by a sharp predominance of sandy and silty rocks. Sands are fine-grained, rarely coarse-grained, grey and light-grey and interlayered with siltstones and sandy clays. Single interlayers of brown coals and gravelites were noted. The thickness varies from 50 to 120 m. The average stratum of 50-110 m is composed mainly of clays with sharply subordinated interlayers of sand and siltstones. The upper layer is represented by uneven, sometimes thin, alternation of sands, sandstones, siltstones and clays of light-grey, grey and dark-grey colour due to abundant plant detritus; the thickness from 115 to 170 m.

*The Turonian (Kuznetsov suite, K<sub>2t</sub>).* This suite, like the underlain one, is spread everywhere, lying on it with erosion (basal horizon with gravel and pebbles), but without visible angular non-conformity. The composition is dominated by greenish-gray clays, thin-layered, and there are concretions of phosphorites, pyrite, fish vertebrae, sponges, and fauna fragments. Sands, sandstones, siltstones, abruptly subordinated in thickness, grey and greenish-grey glauconite-quartz, inequigranular with gravel and pebbles. The suite sediments are well characterized by foraminifer and radiolaria fauna. The thickness varies from 4 to 45-60 m.

*The Coniacian-Campanian (Berezovskaya suite K<sub>2k-km</sub>).* The marine sediments of this age have been penetrated by all deep wells. The lithological composition of the complex within the district is not constant. Within the Yakovlev, Ryavkin, Oktyabrsk and Gankin areas, the section is dominated by greenish-grey and grey, silty and sandy opoka-like clays, in the lower levels, with significant participation of sands and siltstones. The clay horizon is separated into the Slavgorod suite (K<sub>2km</sub>), and the lower half

(K<sub>2k-s</sub>) into the Ipatian unit (suite). The suite is well characterized by the fauna of foraminifera, radiolarians and spore-pollen complexes. The penetrated maximal thickness of the sediments is 141 m.

*The Maastricht (Gankin suite, K<sub>2m</sub>)*. The marine sediments of Maastricht with thickness varying from 18-20 to 140 m are represented everywhere by monotonous stratum of grey, dark-grey and greenish limestone clays, siltstones and marls with subordinate interlayers of sandstones. The formations are characterized by carbonateness and presence of fauna of peletsypods, ammonites and gastropods.

*The Cenozoic deposits* are omnipresent in the area and represented by marine and continental formations. Marine sediments include the Paleocene and Eocene ages. The total thickness of the Paleogenemarine formations reaches 400-460 m.

*Continental sediments of the Oligocene-Pliocene* with a total capacity of 100-140 m lie on the sea clays of the Chegansuite with deep erosion. Their section is dominated by sands, siltstones and clays, unevenly interchanged between each other.

As can be seen from the above, starting from the Jurassic and downwards, the horst-grabeneriftogenic structures are showing up in the lower Mesozoic and upper Paleozoic, which favours the area's oil and gas potential. As the 2D-3D study surveys are badly lacking, it is difficult to determine the prospects of oil-and-gas-bearing capacity. Therefore, it is desired to conduct a regional 2D-seismic survey to the north of Petropavlovsk, in the area of the Bugrov, Vinogradov and Voskresensk moulds (Fig. 1), detected as per data acquired during the magnetoexploration: the magnetoactive surface was submerged down to depths of 3500 m, and a parametric well was drilled in the central part of the Bugrov mould with a design depth of 3500 m.

Ә. Б. Биғарасев, Ә. С. Мусина

Satbayev University, Қ. И. Сәтбаев атындағы геологиялық ғылымдар институты, Алматы, Қазақстан

### СОЛТҮСТІК ҚАЗАҚСТАН ШӨГІНДІ БАССЕЙІНІНІҢ ГЕОЛОГИЯЛЫҚ ҚҰРЫЛЫМЫ, ЗЕРТТЕЛУ ЖАҒДАЙЫ ЖӘНЕ МҰНАЙГАЗ ПЕРСПЕКТИВАСЫ

**Аннотация.** Ауданы 55 мың. км<sup>2</sup> Солтүстік-Қазақстан шөгінді алабы ұлаңғайыр Батыс-Сібір мұнайгазды мега-алабының оңтүстік шалғайын алып жатқан Солтүстік-Қазақстан моноклиналинде орналасқан. Солтүстік-Қазақстан шөгінді алабы оңтүстігінде ғана Көкшетау массивімен шектеліп айқын шекараға ие, ал солтүстігіндегі шекара ретінде ҚР мемлекеттік шекарасы есептеледі. Батысында да айқын морфологиялық шекара жоқ, бірқалыпты түрде Солтүстік-Торғай алабына ұласып 66<sup>0</sup> шығыс бойлықтан шығысырақ жерде ҚР Қостанай мен Солтүстік Қазақстан облыстарының арасындағы әкімшілік шекараға сай келетін шартты шекарамен шектеледі. Әкімшілік тұрғыдан алғанда алап Солтүстік Қазақстан облысы аумағында орналасқан.

Солтүстік-Қазақстан алабындағы геофизикалық жұмыстар 1937 жылы магнитометрлік жұмыстар жүргізілуден басталды. Бірқатар магниттік аномалиялар анықталып, олардың аумағында ШТӘ және СТКӘ сейсмикалық жұмыстары жүргізілді.

1937-1943 жж. Батыс-Сібір экспедициясының палеозой түзілімдерінің үстінде жүргізген геофизикалық зерттеулерінің нәтижесінде (сейсмосбарлау, магнитобарлау) Асановское, Токушинское, Яковлевское, Рякинское және Октябрьское жергілікті көтерілімдері ашылды. Асановское көтерілімінде 1940-43 жж. үш ұңғыма, ал қалғандарында 1952-54 жж. – 13 ұңғыма бұрғыланды. Барлық ұңғымалар палеозой түзілімдерін ашты және 1200 м-ден 1880 м-ге дейінгі тереңдіктерде сол түзілімдерде тоқтатылды. Ықтималды мұнайлылықтың белгілері анықталған жоқ.

50-ші жылдар басында Омбы геофизикалық кеңсесі Асанов-Октябрьское құрылым топтарында шөгінді мезозойлық тыс пен палеозойлық түзілімдерді зерттеу мақсатында, ал 1951 ж. – теміржол желісінің бойымен Петропавловск-Новосибирск аймақтық бағытында ШТӘ, СТКӘ мұнай мен газ геофизикалық жұмыстарын жүргізді.

1959 ж. аймақтық профильдер бойынша СТКӘ сейсмосбарлау жұмыстарын Солтүстік-Қазақстан геофизикалық экспедициясы атқарды. Профильдердің солтүстік учаскелерінде шағын көлемде ШТӘ сейсмосбарлау жүргізілді. Профильдердің бағдары негізінен субмеридионалды болды.

Мезокайназой тысы қалыңдығының оңтүстіктен солтүстікке және солтүстік-шығысқа қарай бірқалыпты артуы, ал палеозой беті тереңдігінің оңтүстік бағытта бірінші жүздеген метрден Ресеймен шекарада 1500-1600 м-ге дейін артуы анықталды. Аумақтың геологиялық құрылысы жайлы түсінік нақтыланды. Басты сыну шекарасы – палеозой түзілімдерінің эрозияланған беті және мезозой қабатындағы маңызы азырақ бірнеше шекара анықталды.

2Д және 3Д ОТН заманауи сейсмикалық әдістерін қолданған мұнай іздеу жұмыстары алап аумағында жүргізілмеген. Қазіргі күн көзқарасымен алғанда алап нашар зерттелген аумақтар қатарына жатады. Ресей аумағында кейінгі геолого-геофизикалық жұмыстар көмегімен Петропавл қаласынан 250-300 км солтүстікте мезозой түзілімдерінде Тевризское, Тайтымское, Прирахтовское кенорындары, ал 450 км солтүстік-батыста палеозой түзілімдерінде – Малоичское, Верх-Тарское, Урманское, Калиновое кенорындары ашылды. Солтүстік-Қазақстан алабы аумағын терең бұрғылаумен зерттеу 2 кезеңде жүргізілді. Асановское көтерілімінде 1940-43 жж. үш ұңғыма, ал қалғандарында 1952-54 жж. – 13 ұңғыма бұрғыланды. Барлық ұңғымалар палеозой түзілімдерін ашты және сол түзілімдерде 1200 м-ден 1880 м-ге дейінгі тереңдіктерде тоқтатылды. Қарастырылып отырған аумақтың геологиялық құрылысында докембрий, палеозой, мезозой және кайнозой түзілімдері қатысады. Құрамы, орналасу дәрежесі және орналасу жағдайлары бойынша олар 3 түрлі кешенге бөлінеді: докембрий мен төменгі палеозойдың қатты орналасқан және айтарлықтай метаморфизденген түзілімдері, ортаңғы және жоғарғы палеозойдың орташа орналасқан шөгінділері және суасыты қозғалысындағы - юра, бор және кайнозой жасындағы шөгінділері. Бірінші кешен гранитоид құрамды интрузиясымен жарылған кристалды іргетасты құрайды. Екінші кешен аралық-квази-платформалық қабат құрайды. Үшінші кешеннің шөгінділері қалыңдығы 1200-1600 м-ге жететін платформалық тыстың құрамына кіреді. Юрадан бастап және төмен қарай мезозойдың төменгі жағында және жоғарғы палеозойда горст-грабенді рифтогенді құрылым бейнеленеді, бұл ауданның мұнай-газдылығы перспективасының критерийлерін арттырады.

Мақалада Солтүстік Қазақстан шөгінді бассейніндегі барлық геолого-геофизикалық материалдарды топтап және зерделеу негізінде, бассейнің геологиялық құрылысының және тектоникалық ерекшеліктері келтіріліп, сондай ақ мұнайгаздылық тұрғысынан бассейнің зерттелу деңгейі мен мұнайгаз перспективасы зерделенген және де ары қарай зерттеу жұмыстарының бағыты анықталған.

Осыған байланысты, магниттік барлау деректері бойынша анықталған Бугровс, Виноградов және Воскресенск мұльда аймағында 2D сейсмикалық барлауын жүргізу ұсынылады.

**Түйін сөздер:** Шөгінді бассейн, рифттік құрылысы, мұнайгаздылық перспективасы, юра шөгінділері, квази-платформалық комплекс.

**А. Б. Бигараев, Э. С. Мусина**

Satbayev University, ТОО «Институт геологических наук им. К. И. Сатпаева», Алматы, Казахстан

## **СОСТОЯНИЕ ИЗУЧЕННОСТИ, ОСОБЕННОСТИ ГЕОЛОГИЧЕСКОГО СТРОЕНИЯ И ПЕРСПЕКТИВЫ НЕФТЕГАЗОНОСНОСТИ СЕВЕРО-КАЗАХСТАНСКОГО ОСАДОЧНОГО БАССЕЙНА**

**Аннотация.** Северо-Казахстанский осадочный бассейн с площадью 55 тыс. км<sup>2</sup> приурочен к Северо-Казахстанской моноклинали, занимающую южную периферийную окраину обширного Западно-Сибирского нефтегазоносного мега-бассейна. Северо-Казахстанский бассейн имеет четкую тектоническую границу только на юге и ограничивается Кокшетауским массивом, северной границей условно служит государственная граница РК, а на западе также не имеет четкой морфологической границы, плавно переходит на Северо-Торгайский бассейн и отделяется условной границей восточнее 66<sup>0</sup> восточной долготы, совпадающей с административной границей между Костанайской и Северо-Казахстанскими областями РК. В административном отношении бассейн расположен на территории Северо-Казахстанской области

Геофизические исследования в Северо-Казахстанском бассейне начаты в 1937 году, когда проводились магнитометрические работы, выявившие ряд магнитных аномалии, на которых впоследствии были поставлены сейсмические работы МОВ и КМПВ.

В результате геофизических исследований (сейсморазведка, магниторазведка), проведенных в 1937-1943 гг. Западно-Сибирской экспедицией, по поверхности палеозойских отложений выявлены локальные поднятия Асановское, Токушинское, Яковлевское, Рязкинское и Октябрьское. Асановское поднятие разбурено в 1940-43 гг. тремя скважинами, остальные поднятия – в 1952-54 гг. – 13 скважинами. Все скважины вскрыли отложения палеозоя и остановлены в них при глубинах от 1200 до 1880 м. Признаки возможной нефтегазоносности не были обнаружены.

Омской геофизической конторой в начале 50-х годов выполнялись геофизические исследования на нефть и газ МОВ, КМПВ по изучению осадочного мезокайнозойского чехла и палеозойских отложений на Асановско-Октябрьской группе структур, а в 1951 г. – по региональному маршруту Петропавловск – Новосибирск вдоль линии железной дороги.

С 1959 г. сейсморазведочные работы КМПВ по региональным профилям выполняет Северо-Казахстанская геофизическая экспедиция. На северных участках профилей в небольших объемах выполнена сейсморазведка МОВ. Ориентировка профилей, в основном, субмеридианальная.

Установлено плавное увеличение толщины мезокайнозойского чехла с юга на север и северо-восток, а глубин поверхности палеозоя от первых сотен метров на южных флангах профилей до 1500-1600 м на границе с Россией. Были уточнены представления о геологическом строении территории. Прослежена основная преломляющая граница, – эродированная поверхность палеозойских отложений и несколько менее значимых границ в мезозойской толще.

Нефтепоисковые работы современными сейсмическими методами ОГТ 2Д и 3Д на территории бассейна не проводились. С позиции сегодняшнего дня бассейн относится к слабо изученным территориям. Более поздними геолого-геофизическими работами на территории России, в мезозойских отложениях на расстоянии 250-300 км севернее г. Петропавловск были открыты Тевризское, Тайтымское, Прирахтовское месторождения, а в палеозойских отложениях – в 450 км на северо-восток – месторождения Малоичское, Верх-Тарское, Урманское, Калиновое. Изучение территории Северо-Казахстанского бассейна глубоким бурением проводилось в два этапа. На Асановском поднятии в 1940-43 гг. пробурены 3 скважины, остальные площади разбурены в 1952-54 гг. Пробурено 13 скважин. Все скважины остановлены в породах палеозойского возраста, считавшиеся тогда фундаментом при глубинах от 1200 до 1880 м.

В геологическом строении рассматриваемой территории принимают участие образования докембрия, палеозоя, мезозоя и кайнозоя. По составу, степени дислоцированности и условиям залегания они делятся на 3 различных комплекса: сильно дислоцированные и значительно метаморфизованные образования докембрия и нижнего палеозоя, умеренно дислоцированные отложения среднего-верхнего палеозоя и недислоцированные – юрского, мелового и кайнозойского возрастов. Первый комплекс образует кристаллический фундамент, прорванный интрузиями гранитоидного состава. Второй комплекс образует – промежуточный-квазиplateформенный этаж. Отложения третьего комплекса входят в состав платформенного чехла, мощность которого достигает 1200-1600 м. Начиная от юры и вниз, вырисовывается горст-грабенное рифтогенное строение в низах мезозоя и в верхнем палеозое, что повышает критерии в пользу перспектив нефтегазоносности района.

В связи с этим рекомендуется проведение региональной сейсморазведки 2Д в районе Бугровской, Виноградовской и Воскресенской мульд, выявленных по данным магниторазведки.

**Ключевые слова:** осадочный бассейн, рифтовое строение, перспективы нефтегазоносности, юрские отложения, квазиplateформенный комплекс.

#### Information about the authors:

Bigaraev A.B., doctor PhD, The K. I. Satpaev Institute of Geological Sciences, Satbayev University, Almaty, Kazakhstan; anuarbek\_bi@mail.ru; <https://orcid.org/0000-0001-6277-7438>

Mussina E.S., Master of Engineering and Technology, The K. I. Satpaev Institute of Geological Sciences, Satbayev University, Almaty, Kazakhstan; musina.63@mail.ru; <https://orcid.org/0000-0001-7558-9292>

#### REFERENCES

- [1] Abdulin A.A., Cirel'son B.S., Bykadorov V.A. et al. «Tektonika oblasti sochleneniya struktur Urala, Tyan'-Shanyai Central'nogo Kazakhstana» [the Joint region tectonics of the Uralian structures, Tian-Shan and Central Kazakhstan]. Alma-Ata, Nauka, 1978. 238 p.
- [2] Akchulakov U.A., Bigaraev A.B. et al. «Aryskumskij transkontinental'nyj riftovyj pojas i ego neftegazonosnost'» [Aryskum transcontinental rift belt and its oil and gas content]. «Nef't' igaz» 2013 (5). P. 75-80.
- [3] Akchulakov U.A., Bigaraev A.B. Osobennosti geologicheskogo stroeniya Severo-Torgajskogo riftovogo osadochnogo bassejna I kriterii perspektiv neftegazonosnosti [Features of the geological structure of the Severo-Torgairift sedimentary basin and oil and gas potential criteria]. Almaty, «Nef't' igaz» 2016, 3 (93). P. 7-19.
- [4] Daukeev S.Zh., Vocalevskij E.S. «Glubinnoe stroenie I mineral'noe resursy Kazakhstana» [Deep structure and mineral resources of Kazakhstan]. Vol. III. Almaty, «Nef't' igaz», 2002.
- [5] Zholtaev G. Zh. «Geodinamicheskie modeli I neftegazonosnost' paleozojskih osadochnyh bassejnov Zapadnogo i Yuzhnogo Kazakhstana (avtoreferat dissertacii doktora g.-m. nauk)» [Geodynamic models and oil and gas bearing capacity of Paleozoic sedimentary basins of Western and Southern Kazakhstan (author's abstract of the dissertation of Doctor of Sciences, Moscow)]. M., VNIGNI 1992.
- [6] «Tektonikamolodyh platform» [Tectonics of young platforms]. M., «Nauka» 1984, 184 p.
- [7] Zholtaev G.Zh., Iskaziev K.O., Abayildanov B.K. Paleozoic deposits as option for reserves replacement & expansion of raw material base for petroleum industry in Mangyshlak//News of the national academy of sciences of the republic of Kazakhstan series of geology and technical sciences ISSN 2224-5278 <https://doi.org/10.32014/2018.2518-170X.1> Vol. 5, N 431 (2018). 163 p.

**NEWS**

OF THE NATIONAL ACADEMY OF SCIENCES OF THE REPUBLIC OF KAZAKHSTAN

**SERIES OF GEOLOGY AND TECHNICAL SCIENCES**

ISSN 2224-5278

Volume 2, Number 440 (2020), 48 – 54

<https://doi.org/10.32014/2020.2518-170X.30>

UDC 669.162 16:581.52

**Pavlo Bosak<sup>1</sup>, Vasyl Popovych<sup>1</sup>, Kateryna Stepova<sup>1</sup>, Roman Dudyn<sup>2</sup>**

<sup>1</sup>Lviv State University of Life Safety, Lviv, Ukraine;

<sup>2</sup>National Forestry University of Ukraine, Lviv, Ukraine.

E-mail: bosakp@meta.ua

## **ENVIRONMENTAL IMPACT AND TOXICOLOGICAL PROPERTIES OF MINE DUMPS OF THE LVIV-VOLYN COAL BASIN**

**Abstract.** To date, the environmental status of mining areas is characterized as critical. The prerequisites for this are the formation of artificial landscapes (waste heaps, mine wastewater, etc.), high concentration of mining enterprises in mineral deposits, inefficiency of measures to maintain mining facilities in a safe state, low level of continuous monitoring of environmental change. The uncontrolled impact of mining areas leads to a general exacerbation of the environmental problems of the region as a whole, as well as to the depletion of surface and groundwater and the contamination of surrounding metals by heavy metals due to their migration from the mine heaps.

The article discusses the features of the Lviv-Volyn coal basin as a background for industrial development of Western Ukraine. The characteristics of the dumps of the closed up mine of the basin has been carried out. The toxicological composition of the dumps of the Novovolynska mine has been investigated and their environmental impact has been defined. Waste dumps of mine rocks of Lviv-Volyn area have high acidity, considerable content of various salts and sulfate ions. This high mineralization is caused by the movement to the water-collection points and the interaction of such water with rock dumps besides, and its way waste water is enriched with products of rocks destruction and coal.

**Key words:** coal, Lviv-Volyn coal basin, environment, mine dumps, toxicological indicators.

**Introduction.** Sustainable socio-economic development of modern society is impossible without assessment of man-made impact on the environment. Nowadays, developmental challenges in different Ukrainian regions are caused by anthropogenic processes that lead to environmental pollution. Particular attention should be paid to the investigation of the regions in which the coal industry is developed [3].

During the period of coal mining and coal processing operations in the territory of Lviv-Volyn coal basin the geo-ecological environment has undergone significant changes. This is primarily due to the change in the natural landscape, the impact of the coal processing waste on the environment, as well as the change of geochemical indicators caused by the additional discharge of chemical and mineral compounds.

One of the main sources of environmental hazards for the region is mine dumps. Thus, when coal is extracted from the rock mass, which is brought to the surface, up to 75% of the raw material goes to waste [5]. Mine rocks accumulate in waste dumps, sludge pits, ash dumps etc. The refore a reliable assessment of toxicity of mine dumps is an important issue while designing environmental measures for minimizing their impact on the environment.

**Purpose, tasks and methods of research.** Problems related to the impact of mine dumps on all components of environment have been studied in Ukraine and abroad for a long time. The papers of Ukrainian authors, in which environmental issues of mining were considered in the context of environmental issues, contain analysis of the critical geo-ecological situation in specific regions and methodological approaches for assessment of their urgency as well as the recommendations for their solution. At the same time, the environmental issues of the Lviv-Volyn coal basin and the assessment of mining waste impact remain relevant. The object of the paper is determination of environmental impact and toxicological properties of mine dumps of the Lviv-Volyn coal basin (figure 1).

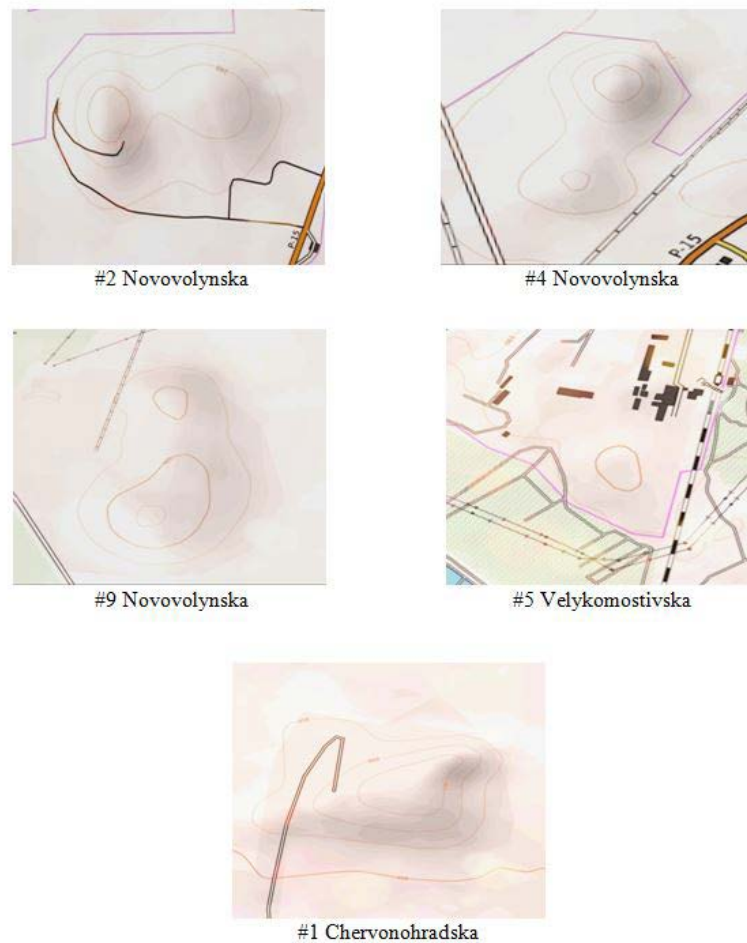

Figure 1 – Cartographic map of coal mine dumps #2 Novovolynska, #4 Novovolynska, #9 Novovolynska, #5 Velykomostivska, # 1 Chervonohradska

**Results and their discussion.** The Lviv-Volyn coal basin is located in Western Ukraine. It covers the territory of the northwestern part of Lviv and southwestern part of Volyn region. The northern border of the basin is defined by the line of Volodymyr-Volynskiy – Torchyn, and the eastern border by the Torchyn-Olesko line. The coal here lies almost horizontally at a depth of more than 315-550 m [7]. The geographical location of the Lviv-Volyn basin is generally favorable for its economic development. It caused the intensive coal mining. In the second half of the twentieth century a powerful cross-sector fuel-power complex was created. The main component in the functional structure of the basin is the coal-energy production cycle, which includes the coal industry and related coal consumption sectors (electricity, transport) and production services (production of building materials, building and construction, repair of mining equipment). Basing on the coal and electricity industries, mechanical engineering, chemical, food and consumer industries have also developed, an extensive industrial and social infrastructure has been created, an area of intensive peri-urban agriculture has been formed [6].

In the early 90's the coal industry of the Lviv-Volyn coal basin included 21 mines and a central processing plant. In the Lviv part of the coal basin there were 12 coal mines (in Hirnyk - 2, in Sosnovka - 3, in Chervonograd - 7 mines). What is more the central Chervonograd processing plant was built in Sosnovka. In the Volyn part of the basin there were 9 mines (2 in the village of Blagodatny (Zhovtneve) and 7 in the Novovolynsk district). However, due to the economic crisis, the situation in the coal industry of the Lviv-Volyn basin has deteriorated significantly. Due to the fact that coal production has decreased significantly, the number of employees in the industry has decreased, renovation of production facilities has stopped, and the process of unprofitable mining sites closure has begun.

Only since 2002 the slow revival of the Lviv-Volyn coal basin did begin. Unprofitable mines were abandoned, and coal companies were reorganized into state-owned enterprises. Today, the Lviv-Volyn

Basin coal basin industry includes two state-owned enterprises, Lvivvugillya and Volynvugillya, comprising 9 and 4 coal mines respectively. The main consumers are Burshtyn, Dobrotvir, Ladizhin and Kalush CHPPs, the regional fuel department of the western regions of Ukraine, some commercial organizations and people [4].

As some mines within the Lviv-Volyn coal basin were closed, the problem of their technogenic risk remained unresolved. The factors of man-made pressure on the environment of the basin are: flooding of mines, blockages and landslides of mine shafts, subsidence of the surface, high radiation background of waste dumps and terrain, the release of toxic elements, compounds and products of combustion into water reservoirs, soils, air [2].

At the present time, considerable attention is paid to the environmental safety of the mine waste dumps, as a large number of people living near these man-made objects suffer from smog, products of self-ignition and smoldering of the rock, disfigurement of a landscape, etc. The main technogenic impact of mine complexes is so-called technogenic landscapes - dumps of waste rock - waste heaps, which cause a number of problems. They pollute almost all elements of the environment: air, ground water, land runoff, soil, plants. In this regard, we decided to investigate the toxicological composition of the dumps of mine # 9 "Novovolynska" and their on environmental impact [9].

Mine # 9 "Novovolynska" belongs to the State Enterprise "Volynvuhillya" and is located on the territory of Ivanychi region of Volyn region. Coal has been produced here since 1963. The flat dump is located 150 m north of the industrial site. Its height is approximately 30 m. 5.5 million tons of waste covers the area of over 120 000 m<sup>2</sup>. Samples were taken at a depth of 15-20 cm from the surface of the dump. Investigation of the toxicological properties of waste heaps of mine # 9 "Novovolynska". The results are in tables 1 and 2.

Table 1 – Characteristics of waste dumps of closed mines

Dump	Mine	City, district	Shape of the dump	Dump state burning, not burning)	The organization to which the dump was handed over
1	# 1 Chervonohradka	Chervonohrad	frustum of a cone	not burning	The rock was taken out, the land was handed over to the Chervonograd land fund in 2000
1	#5 Velykomostivska	Volsvyn, Sokal region	conical	not burning	Handed over to the Volsvyn (Sokal region) land fund in 2005
2			flat	not burning	
3			flat	not burning	
1	#2 Novovolynska	Novovolynsk	conical	not burning	Handed over to the Novovolynsk land fund
2			flat	not burning	
1	#4 Novovolynska	Novovolynsk	conical	not burning	Under recultivation
2			conical	not burning	
1	#9 Novovolynska	Hrydiv, Ivanychiv region	conical	not burning	Handed over to the Hrydiv (Ivanychi region) land fund in 2006
2			flat	not burning	
3			flat	not burning	
4			flat	not burning	

Table 2 – Toxicological properties of waste rock of mine # 9 "Novovolynska"

Index	Unburnt rock	Raw rock	Southern slope	Western slope
pH	3,63-4,81	5,59	7,18	8,4
Hydrolytic acidity mg-eq./100g of soil	10,6	0,21	0,22	0,29
Total absorbed bases (Ca+Mg), eq./100g. of soil	13,5	30,1	48,1	51,4
Humus, %	2,21-6,94	9,52	7,53	0,49
Nitrogen, mg/kg	49,8-59,9	29	14,2	16,9
P <sub>2</sub> O <sub>5</sub> , mg/kg	13	214	11	28
K <sub>2</sub> O, mg/kg	64	201	79	42

Investigation of the toxicological properties of the waste rock of mine # 9 "Novovolynska" have shown that the unburned rock is acidic: the pH of salt extract varies within 3,63-4,81. The hydrolytic acidity is quite high - 10.6 mg/100g of soil and more. The soil on the slopes has an alkaline reaction and a much lower hydrolytic acidity (0,22-0,29). The total absorbed bases (Mg and Ca) is minimal in the dump rock and averages 16.29 mg/100g of soil. It is higher on the slopes - 48.1 mg/100g of soil. The humus index of unburned rock ranges from 2,21-6,94%. The humus content differs in the samples taken on the western and southern slopes (0,49% and 7,53%). The highest humus content is in the raw rock – 9,52% [1,12].

Technical unburned rock is characterized by a very low content of exchange nitrogen 49,8 mg / kg. Much less N<sub>2</sub> is present in soil on the slopes of the dump 14.2 mg/kg. The highest content of phosphorus and potassium is found in raw rock. The mineral and chemical composition of the dump rock affects both the geochemical environment of the region and the health of the population, as some trace elements accumulated in the dumps lead to poisoning of flora and fauna and humans, since their content exceeds the MPC [8]. The content of heavy metals in the waste dump is as follows (figure 2 and 3).

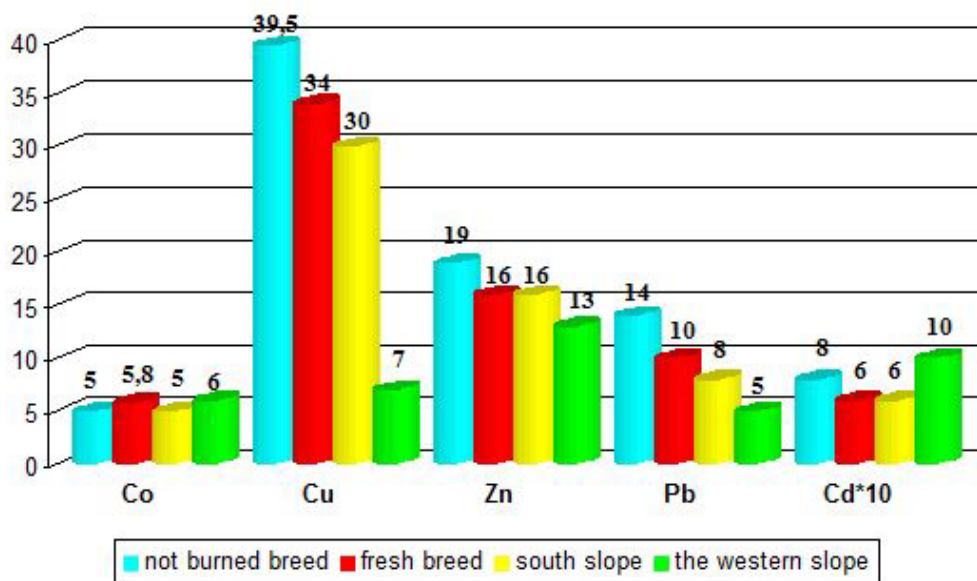

Figure 2 –Total content of heavy metals in the dump rock, mg/kg

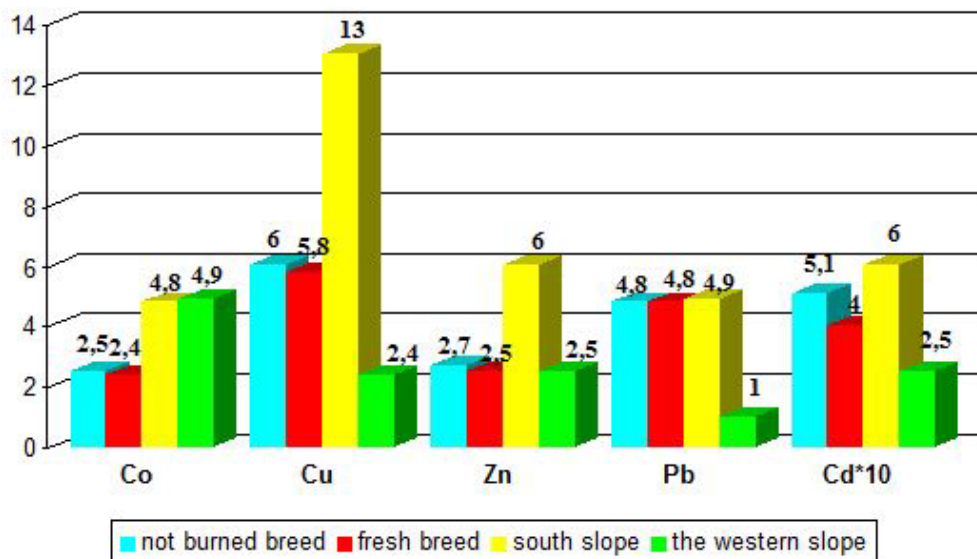

Figure 3 – Content of active forms of heavy metals in dump rock, mg/kg

The distribution of lead in the dump is uneven. Higher concentrations of lead are found in the waste rock, although the concentrations exceeding MPC are detected both on the slope of the dump and in the rock itself. The average total zinc content in rocks and slopes reaches 0.3% of MPC. Most of the active zinc can be found on the slopes of the dump. Its content doesn't exceed the acceptable limits.

The best aggregates for copper accumulation are unburnt rocks. The highest content of active copper is defined in the technical soil of the slopes, while on the southern slope its content exceeds of the MPC by more than 4 times. The slopes of the dump are characterized by a high content of cobalt that exceeds the content in the rock by 4 times. The maximum concentration of the total cadmium is detected on the slopes of the dump, the minimum - in the dump rock. In general, its content does not exceed the MPC in the soil 3.0 mg/kg. The maximum concentration of active cadmium is also detected on the slopes of the dump, and the minimum - in the waste rock. In general, its content does not exceed the MPC in the soil 0.7 mg/kg [10,14].

As a result, we should note that the accumulation of waste dumps of mine rocks causes the following technogenic changes in the area around "Novovolynska" mine # 9:

- accumulation of loose and unstable waste rock containing corrosive chemical substances;
- change of the groundwater balance and depletion of aquifers due to disturbance of natural circulation;
- lands loss due to flooding and pollution;
- pollution of the atmosphere, soil and groundwater, especially by heavy metals; artificial formation of an uncharacteristic microclimate around the mine.

**Conclusions.** The investigation revealed significant differences in the toxicological composition of mine waste dumps in different locations. Unburnt rock is the most acidic in comparison to the raw one and to the soil on the slopes of the dump. Raw rocks are rich in phosphorus and potassium and are also characterized by a high humus content [11,13]. The best accumulators are the slopes of the dump.

Accumulation of toxic constituents in technological dumps creates a significant man-made danger. To prevent the emergence of hazardous manifestations of sewage to the ecological situation in the study area, it is necessary to use natural resources rationally, to timely carry out demineralization and reclamation, phytomelioration of disturbed lands and use a method based on phytotechnology – a hydrophytic structure of the type of bio-plateau, which performs the destruction, transformation and accumulation of nitrogen-containing substances, heavy metals and other toxic substances, ensuring the biological purification of water from pollutants.

**П. В. Босак<sup>1</sup>, В. В. Попович<sup>1</sup>, Е. В. Степовая<sup>1</sup>, Р. Б. Дудин<sup>2</sup>**

<sup>1</sup>Львов мемлекеттік тіршілік қауіпсіздігі университеті, Украина;

<sup>2</sup>Украина ұлттық орман шаруашылығы университеті, Львов, Украина

**ШАХТА ТАМШЫЛАРЫНЫҢ ТОКСИКОЛОГИЯЛЫҚ СИПАТТАРЫ  
ЛЬВОВ-ВОЛЫН ТАС КӨМІРІ ЖӘНЕ ОЛАРДЫҢ ҚОРШАҒАН ОРТАҒА ӘСЕР ЕТУІ**

**П. В. Босак<sup>1</sup>, В. В. Попович<sup>1</sup>, Е. В. Степовая<sup>1</sup>, Р. Б. Дудин<sup>2</sup>**

<sup>1</sup>Львовский государственный университет безопасности жизнедеятельности, Украина;

<sup>2</sup>Национальный лесотехнический университет Украины, Львов, Украина

**ТОКСИКОЛОГИЧЕСКИЕ СВОЙСТВА ОТВАЛОВ ШАХТНЫХ ПОРОД  
ЛЬВОВСКО-ВОЛЫНСКОГО КАМЕННОУГОЛЬНОГО БАССЕЙНА  
И ИХ ВЛИЯНИЕ НА ОКРУЖАЮЩУЮ СРЕДУ**

**Аннотация.** На сегодняшний день экологическое состояние горнопромышленных районов характеризуется как критическое. Предпосылками этого является образование искусственных ландшафтов (отвалы шахтных пород, сточные шахтные воды), высокая концентрация горных предприятий в местах залежей полезных ископаемых, неэффективность мер поддержки горно-технологических объектов, низкий уровень

постоянного мониторинга за изменением экологического состояния окружающей среды. Неконтролируемое влияние горнопромышленных районов приводит как к общему обострению экологических проблем региона в целом, так и к истощению поверхностных и подземных вод и загрязнению тяжелыми металлами прилегающих территорий в результате их миграции с пород шахтных терриконов.

Согласно физико-географическим признакам площадь Нововольнского горнопромышленного района относится к Малому Полесью. С начала добычи каменного угля экологическое состояние Нововольнского горнопромышленного региона значительно ухудшилось. Благоприятными условиями для этого стало образование искусственных породных насыпей, техногенных форм отвалов, накопление шахтных отходов. Нововольнский горнопромышленный район находится под влиянием воздушных масс, поступающих с Атлантического океана и юго-западных континентальных масс Европы. Такое географическое положение сформировало океаническо-континентальный климат, который характеризуется неустойчивыми погодными условиями, высокой относительной влажностью, большим количеством осадков. Ежегодно действующие шахты города Нововольнска выбрасывают на поверхность более 100 тыс. тонн отвальной породы. На породных отвалах накоплено более 30 млн. тонн шахтной породы. Разработка угольных месторождений сопровождается весомыми изменениями геологической среды, обусловленными перемещениями большого количества массивов горных пород. В состав отвальной породы входит много минеральных и химических веществ, что в некоторых случаях приводит к самовозгоранию. Процесс самовозгорания шахтных терриконов региона наблюдается в виде: торможения процесса рекультивации вследствие выгорания саженцев древесных пород; возникновения завалов, оползней; повышения температуры окружающей среды; вредных выбросов пыли и газов в атмосферу; высокой концентрации опасных химических соединений в окружающей среде и т.д. Во время обдувания ветром терриконов и отвалов шахтных пород воздух загрязняется пылью и газами. Водяные потоки сносят рыхлые породы в гидрографическую сеть, загрязняя балки и речные долины, заиливая пруды, реки, озера. Это приводит к устранению из природных мест обитания многих видов растений и животных.

В статье рассматриваются особенности Львовско-Волынского угольного бассейна как предпосылки промышленного развития Западной Украины. Осуществлено характеристику породных отвалов ликвидированных шахт бассейна, а также изучен токсикологический состав отвалов Нововольнской шахты и определено их влияние на окружающую среду. Отвалы шахтных пород Львовско-Волынского каменноугольного бассейна имеют высокую кислотность, значительное содержание различных солей и сульфат-ионов. Эта высокая минерализация обусловлена движением к водосборным пунктам и взаимодействием такой воды с отводами горных пород, а также ее сточные воды обогащаются продуктами разрушения горных пород и угля. Исследования породных отвалов является актуальным, поскольку даёт возможность оценить насколько токсичным является собственно террикон и какую опасность он может представлять для окружающей среды. С тех пор как в городе Нововольнске начали добывать уголь, экологическое состояние региона значительно ухудшилось. Причиной этого стало образование искусственных породных насыпей, техногенных форм отвалов, накопления шахтных отходов, ненадлежащий мониторинг нарушенных земель.

**Ключевые слова:** уголь, Львовско-Волынский угольный бассейн, окружающая среда, отвалы, токсикологические свойства.

#### **Information about authors:**

Bosak Pavlo, lecturer, Department of ecological safety, Lviv State University of Life Safety, Lviv, Ukraine; bosakp@meta.ua; <https://orcid.org/0000-0002-0303-544X>

Popovych Vasyl, Doctor of Technical Sciences, Associate Professor, Head of the Department of ecological safety, Lviv State University of Life Safety, Lviv, Ukraine; [popovych2007@ukr.net](mailto:popovych2007@ukr.net); [http:// orcid.org/0000-0003-2857-0147](http://orcid.org/0000-0003-2857-0147)

Stepova Kateryna, Assistant Professor Environmental Safety Department, Lviv State University of Life Safety, Lviv, Ukraine; [katyastepova@gmail.com](mailto:katyastepova@gmail.com); <https://orcid.org/0000-0002-2082-9524>

Dydun Roman, Assistant Professor Department of landscape architecture, landscape gardening and urban ecology, National Forestry University of Ukraine, Lviv, Ukraine; [drb2008@ukr.net](mailto:drb2008@ukr.net); <https://orcid.org/0000-0003-4539-7489>

**REFERENCES**

- [1] Alekseev Y. Heavy metals in soils and plants. St. Petersburg, Agropromizdat, 1997.
- [2] Bosak P., Popovych V. Radiation-ecological monitoring of coal mines of Novovolinsk mining area. News of the academy of sciences of the republic of Kazakhstan. Series of geology and technical sciences. 2019. Vol. 5. N 437. P. 132-137. <https://doi.org/10.32014/2018.2518-170X.134> ISSN 2518-170X (Online), ISSN 2224-5278 (Print).
- [3] Bosak P. Physico-chemical properties of wastewater from technological waste dumps of Novovolinsk mining district, Visnyk of Lviv State University of Life Safety. 2018. P. 117-124.
- [4] Ivanov E. Landscape-geographical study of the territories affected by the coal industry. Geography and Modern Times, 3, 2010.
- [5] Kroik G. Environmental assessment of mine rocks of the Western Donbass as a source of environmental pollution. Collected scientific works of UkrDGRI, 3, 2013.
- [6] Manko A. Problems of the Lviv-Volyn coal basin. Socio-geographical problems of development of productive forces of Ukraine. Materials of Ukrainian Research Practice Conf, Kyiv, VGL Horizons, 2012 (in Ukr.).
- [7] Manko A. Lviv-Volyn coal basin: problems and prospects. Modern problems and trends of geographical science. Materials of international. Research Practice Conf. in Lviv. University, 2009 (in Ukr.).
- [8] Panov B. Technogenic mineralization and geochemical peculiarities of rocks of mine heaps. Problems of ecology, 4, 2010 (in Ukr.).
- [9] Popovych V., Stepova K., Voloshchyshyn A., Bosak P.: Physico-Chemical Properties of Soils in Lviv Volyn Coal Basin Area. E3S Web Conference. IVth International Innovative Mining Symposium. Vol. 105, 02002, 2019.
- [10] Popovych V., Kuzmenko O., Voloshchyshyn A., Petlovanyi M.: Influence of man-made edaphotopes of the spoil heap on biota. E3S Web of Conferences. Vol. 60. 00010, 2018.
- [11] Popovich V.: Reclamation of waste heaps of liquidated mines of Lviv-Volyn coal basin. Scientific Bulletin of NLTU Ukraine, 27 (3), 2017.
- [12] Chetveryk, M., Bubnova, O., Babii, K., Shevchenko, O., & Moldabaev, S. (2018). Review of geomechanical problems of accumulation and reduction of mining industry wastes, and ways of their solution. Mining of Mineral Deposits, 12(4), 63-72. <https://doi.org/10.15407/mining12.04.063>
- [13] Mukhamedzhanov M.A., Sagin Jai, Kazanbaeva L.M., Rakhmetov I.K. (2018) Influence of anthropogenic factors on hydrogeochemical conditions of underground drinking waters of Kazakhstan. News of the National Academy of Sciences of the Republic of Kazakhstan. Series of Geology and Technical Sciences. Vol. 5, N 431 (2018), P. 6-8. <https://doi.org/10.32014/2018.2518-170X.81> ISSN 2518-170X (Online), ISSN 2224-5278 (Print).
- [14] Tsheshkovskaya Ye.A., Golubeva E.I., Ibrayev M.K., Oralova A.T., Tsoy N.K., Issabayeva M.B. Technogenic impact of mining industry on environment in Karaganda region of Republic of Kazakhstan. Series of Geology and Technical Sciences. Vol. 6, N 438 (2019), P. 85-95. ISSN 2518-170X (Online), ISSN 2224-5278 (Print). <https://doi.org/10.32014/2019.2518-170X.159>

**NEWS**

OF THE NATIONAL ACADEMY OF SCIENCES OF THE REPUBLIC OF KAZAKHSTAN

**SERIES OF GEOLOGY AND TECHNICAL SCIENCES**

ISSN 2224-5278

Volume 2, Number 440 (2020), 55 – 62

<https://doi.org/10.32014/2020.2518-170X.31>**D. F. Goncharenko, A. Y. Aleinikova, A. V. Ubiivovk**

Kharkiv National University of Construction and Architecture, Kharkiv, Ukraine.  
E-mail: gonch@kstuca.kharkov.ua, alevtynaal222@gmail.com, quartv@gmail.com

**DEVELOPMENT OF A REHABILITATION METHOD  
FOR SEWER TUNNELS AT THE JUNCTIONS  
TO INSPECTION SHAFTS**

**Abstract.** In the context of the underfunding of the sewer system sector and high depreciation of the distribution system for wastewater disposal, operating companies conduct their business at the limit of their technical and economic capabilities. The complexity of the operation of sewer tunnels resides in their non-repairability. Therefore, a promising area of research is to extend their durability through the development of alternative repair technologies from an economic point of view, which will ensure their smooth operation under conditions of limited funding. The findings of the research on the causes of failures in operation of sewer tunnels are presented. Using the expert evaluation method, it is found that the main cause of emergency situations is damage to the arched section of tunnels at their junctions to inspection shafts. A new method was developed for rehabilitating sewer tunnels in places where they adjoin inspection shafts using reinforced concrete rings with corrosion-resistant coating. A numerical simulation of the stress-strain state of the tunnel's reinforcement structure was performed. The expediency of the proposed method for rehabilitating sewer tunnels at their junctions to inspections shafts was presented and substantiated. Through the use of this method, the cost saving of financial resources for materials is tripled in comparison with other materials.

**Key words:** sewer tunnel, deterioration, inspection shaft, corrosion, rehabilitation method.

**Introduction.** As numerous cases of collapsed sewer tunnels have shown, concrete and reinforced concrete structures do not last for their guaranteed lifetime and frequently fail before their rated service life (20 to 30 years) [1,2]. In this case, the main cause of the collapses is the susceptibility of their arched section to the effects of biogenic corrosion. Particular attention, when considering the issue of rehabilitating the structures of sewer tunnels, requires to be paid to the corrosion of concrete and reinforced concrete structures, the widespread use of which has resulted in a situation where almost all the tunnels erected and put into operation since the early 1950s, are currently in disrepair [3].

The development of sewer system operating services under conditions of limited funding for the industry is aimed at increasing the durability of the distribution system by developing new technologies for their repair and rehabilitation, which will ensure its smooth operation at optimum cost-performance ratio. Furthermore, an increase in the amounts of rehabilitation work on sewer tunnels raises the requirements as regards the environmental safety of construction work during the operation and repair of distribution networks in the existing urban area conditions. Accordingly, this makes it necessary to use technical facilities that ensure work is carried out according to the most appropriate methods in terms of the cost-performance ratio [4,5].

It should be noted that in conditions of limited financial resources, additional attraction of financial resources due to foreign loans is necessary [6].

The search for rational methods for repairing tunnels is relevant in connection with the reform of Ukrainian environmental legislation to comply with environmental standards of the European Union [7].

This shows that the area of research on the development of rational methods for rehabilitating sewer tunnels is relevant.

**Literature data analysis and setting of the problem.** Comprehensive studies on operating reliability and trouble-free operation of wastewater pipelines of various diameters clearly show that

currently, preference is given to using trenchless technologies that are more cost-effective than traditional ones (open-cut involving excavation). The results of many years research on the cause-and-effect relationship of emergency situations in the pipelines of the water and sewage utilities are consolidated in the work [8], with particular attention paid to the impact of the technical condition of the system on the quality of provided services. The issue of rehabilitating sewer tunnels from precast reinforced concrete structures using multi-component building materials is considered in the work [8]. In the work [10], particular attention is paid to filling the annular space using trenchless technologies. In this case, a multicomponent mixture is used to reduce friction of surfaces and stabilize soils during the repair of utilities, in particular when using the Relining technology. Multifactor studies on using polyethylene pipes, polymer liners in the rehabilitation of pipelines over the course of their further operation are presented in the work [11]. It should be noted that the above-mentioned works describe quite comprehensively the issues related to the extension of the service life of utilities systems, while the lifetime of a sewer tunnel has its own peculiarities of maintaining smooth operation.

The study [12] illustrates in detail the point repair of linear sections of pipelines using Quick-Lock polymeric mechanical sleeves. Equally important is the environmental aspect of using “closed” technologies, especially when it is a case of sewer tunnels. The work [13] mentions an improvement in the environmental component of the use of trenchless technologies.

With the implementation of IT systems, more and more attention is paid to simulating the processes of repair and operation of pipelines. In order to predict the failure-free operation of utilities systems, an integrated model for smooth operation failure in distribution networks has been proposed [14]. Based on statistical data, it is possible to develop regression models that predict the operational and structural conditions for the functioning of pipelines [15].

In the context of the study of the influence of factors on the trouble-free service life of linear utilities systems, and the feasibility study of work performance indicators, it should be noted as follows:

- The research work [16] presents the results of a detailed study of the protection of reinforced concrete wastewater disposal networks against corrosion of different origin;
- The work [17] gives numerical indicators of longitudinal bending in pipelines exposed to lateral soil movements, which also plays an important role in the performance of construction work.

After reviewing the existing technologies of repair and rehabilitation of sewer networks [18-27], it may be concluded that the organizational and technological solutions for trenchless repair of large-diameter sewer networks of are being enhanced on an ongoing basis in order to improve the cost-performance ratio. In turn, it is relevant to study in detail the issue of the service life of large-diameter sewer tunnels, and to search for organizational and technological solutions to improve trouble-free operation.

**Purpose and objectives of research.** The purpose of this work is to develop and study a new method for rehabilitating sewer tunnels, which will allow it to be used in places where they adjoin inspection shafts, and to reduce the duration and energy consumption when carrying out rehabilitation work.

To achieve the purpose in view, the following tasks were defined:

- To investigate the causes of the collapse of sewer tunnels;
- By using expert evaluation to identify technical parameters affecting the trouble-free operation of large-diameter sewers;
- To develop a method for rehabilitating sewer tunnels in places where they adjoin inspection shafts;
- To obtain technical and economic results of the use of the proposed technology for sewer tunnel rehabilitation.

**Investigation on the causes of failures in smooth operation of sewer tunnels.** The investigation of the service life of sewer tunnels suggests that up to 80-90% of accidents in reinforced concrete pipelines are due to corrosion processes. As the analysis of emergencies in reinforced concrete sewer tunnels shows, the most critical areas of the wastewater disposal networks are areas in the vicinity of stilling pools or inspection shafts. Specifically, in 2018, an emergency failure occurred at the crossover section of the Main deep-laid sewer tunnel on Grekovskaya street in Kharkiv. The section of the collapse was located in the immediate vicinity of the stilling pool of wastewater streams (figure 1).

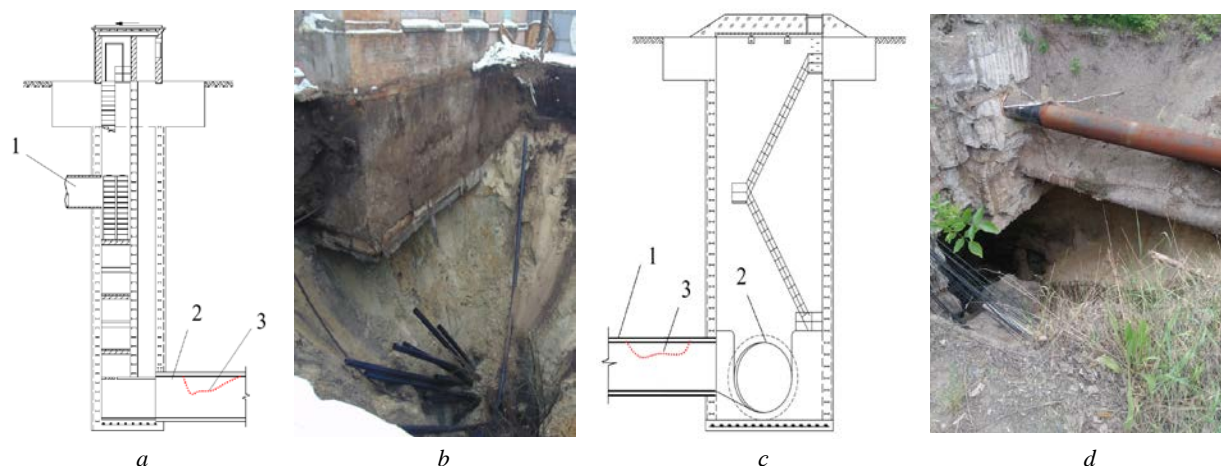

Figure 1 – Emergency failure of the sewer tunnel on Grekovskaya street (Kharkiv, Ukraine, 2017):  
*a* – design solution of the stilling pool; *b* - the consequences of the accident;  
*c* – design solution of the shaft; *d*- the consequences of the accident;  
 1 – sewer incoming into the stilling pool; 2 – arched sewer tunnel; 3 – the area of collapse

The main cause of the local collapse is damage to the reinforced concrete structure of the tunnel arch as a result of exposure to biogenic corrosion. The wastewater in the stilling pool falls from elevation 95.8 to the elevation of the invert of the drainage sewer tunnel of 83.9 ( $H=11.9$  m). As a result of the segregation of the flow, sulfuric gas is extensively released, which in subsequent reactions is converted to sulfuric acid of a high degree of concentration. Without any anticorrosion protection, the concrete lining of the tunnel, which carries the load from the soil mass, is being deteriorated. Due to the disruption of the supporting arch structure, the ground rock was carried out into the tunnel body, followed by the collapse and sinking of the adjacent building. For similar reasons, the sewer tunnel collapsed in the area of the Kharkiv Tractor Plant in 2015-2016.

Based on the monitoring of the service life of sewer tunnels, the main causes of failures in smooth operation of distribution networks have been summarized. Each cause is assigned the symbol C1...C8 (table 1).

Table 1 – Causes of failures in smooth operation of sewer tunnels

Item No.	Failure cause
C1	Deterioration of the tunnel invert by aggressive factors
C2	Systematic increase in wastewater aggressivity
C3	Deterioration of the arched section of the sewer tunnel structure
C4	Technical condition of inspection shafts, stilling pools, chambers
C5	Variations in wastewater volumes
C6	Intensive excavation near the tunnel's route
C7	Deterioration of the arched section at the junctions to inspection shafts, stilling pools, shafts
C8	Drops in the invert's elevations according to the longitudinal profile

According to the expert evaluation method, the ranking of the causes of failures in smooth operation of sewer tunnels was performed [26]. When ranking, an expert in the field of sewer system management arranges the main causes affecting the trouble-free operation of sewer tunnels in the order that they deem to be the most rational and assigns ranks to these. In this case, rank No. 1 obtains the highest measure of significance of impact, while rank No. N has the lowest. Consequently, the ordinal scale obtained as a result of ranking is to meet the condition where the number of ranks "8" is equal to the number of ranked causes of failures "n" [26]. Further, a summary table of ranks was compiled for all experts of the group (table 2).

Table 2 – Findings of the survey of experts included in the group

Failure cause	Expert							Sum
	1	2	3	4	5	6	7	
C1	2	3	1	3	1	2	3	15
C2	6	5	5	5	4	5	5	35
C3	7	8	6	6	7	8	7	49
C4	5	6	8	7	6	6	6	44
C5	1	2	2	1	2	3	4	15
C6	4	4	3	2	3	4	2	22
C7	8	7	7	8	8	7	8	53
C8	3	1	4	4	5	1	1	19
Sum	36	36	36	36	36	36	36	–

To determine the consistency of experts, the coefficient of concordance  $W$  [26] is used. According to the findings of the survey of the experts in the field of sewer network operation and calculations of their consistency, the coefficient of concordance equal to 0.88 was obtained, which indicates a high degree of consistency of opinions in the selected group of experts.

According to the data based on the expert evaluation findings, it should be noted that among the above 8 causes of failures in smooth operation of sewer tunnels, the highest impact on the efficiency of the sewer cleaning method is exerted by causes C7, C3, C4 (the summed rank of these phenomena is minimal), specifically: deterioration of the arched section at the junctions to inspection shafts, stilling pools, shafts; deterioration of the arched section of the sewer tunnel structure; technical condition of inspection shafts, stilling pools, chambers.

Operating experience confirms the fact that about 80% of all collapses of sewer tunnels occur in the area of inspection shafts and stilling pools, where the concentration of sulfuric acid is exceeded by ten folds due to segregation of wastewater streams. It follows from the above that the issue of developing technological solutions for the protection of sewer tunnels in the immediate vicinity of inspection shafts and stilling pools is relevant.

**Development of a rehabilitation method for sewer tunnels at the junctions to inspection shafts.**

To deal with the problem of improving the operating reliability of the sewer tunnel section located in the area of an inspection shaft or a stilling pool, the following technological solutions have been developed to protect them against biogenic corrosion (figure 2).

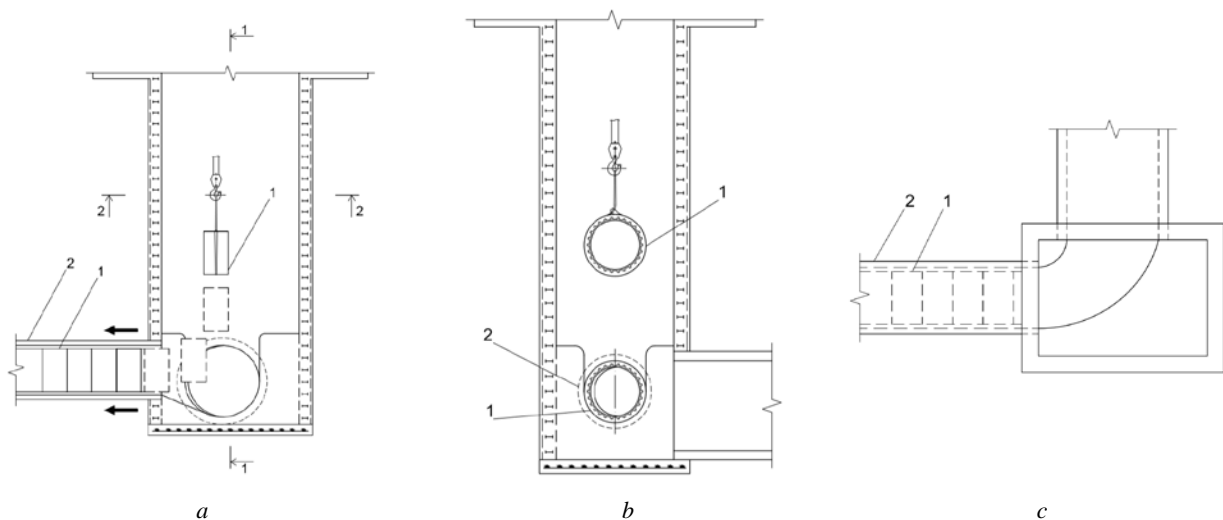

Figure 2 – Rehabilitation of the sewer tunnel at the junctions to inspection shafts:  
*a* – erection process diagram for reinforced concrete rings; *b* – section 1-1; *c* – section 2-2;  
 1 – reinforced concrete ring with corrosion-resistant coating; 2 – sewer tunnel to be rehabilitated

According to the results of teleinspection, the selected section of a sewer tunnel is additionally examined for the nature and degree of susceptibility to biogenic corrosion, with the determination of the exact length to be rehabilitated. After shutting down the movement of wastewater, the elements of the tunnel reinforcement lining, made of reinforced concrete ring elements with corrosion-resistant coating are put by means of winches down into the inspection shaft, previously prepared for rehabilitation work. Next, the elements of the lining are secured in the design position and by the method of buildup are pressed into the tunnel body. Jacks are used for pressing in the lining elements. The connection of the rings to each other occurs by means of couplings or sockets. After completing rehabilitation work, the equipment is dismantled from the shaft, test operations are carried out and the wastewater is started up.

**Findings of research on the rehabilitation method for sewer tunnels at the junctions to inspection shafts.** Preliminary, the thickness of the reinforcement lining is assigned in view of the design requirements and updated according to the results of the calculation by the finite element method performed with regard to the proposed technology of the sewer rehabilitation process. As an example, consider the rehabilitation of a sewer tunnel with a design diameter of 1840 mm, where the following initial conditions are taken for the calculation:

1. The bearing capacity of the existing reinforced concrete lining is assumed to be secured for the period of arrangement of the reinforcement structure, with the presence of localized damaged sections with unsecured strength;
2. The following loading conditions are taken as the design cases for the prefabricated lining of the reinforcement:
  - a) External hydrostatic pressure of the concrete mix during the concrete pouring the annular space;
  - b) External hydrostatic pressure of water filtered in the ground and penetrating through the reinforced concrete lining structure;
  - c) External local asymmetric pressure on the arch section (the case of an emergency condition of the sewer lining to be reinforced).

The design model for lining the reinforcement of the tunnel is a fragment of a cylindrical shell with a design diameter of 1.44 m and a length of 1.0 m, consisting of flat quadrangular finite elements of the shell measuring 0.1 x 0.1 m. The parameters of the material of the finite elements of the design model are as follows: thickness – 180 mm; modulus of elasticity  $E = 1.4 \cdot 10^4$  MPa; Poisson's ratio  $\nu=0.3$ ; ultimate tensile strength – 170 MPa [3].

The boundary conditions are taken in the form of connections in individual units in the longitudinal direction (along the axis of the sewer tunnel), and the coefficients of the elastic foundations for the plates, corresponding to the conditions of the interaction between the reinforcement structure and the nominal linearly elastic medium.

The results of the numerical simulation of the stress-strain state of the reinforcement structure are given in figure 3.

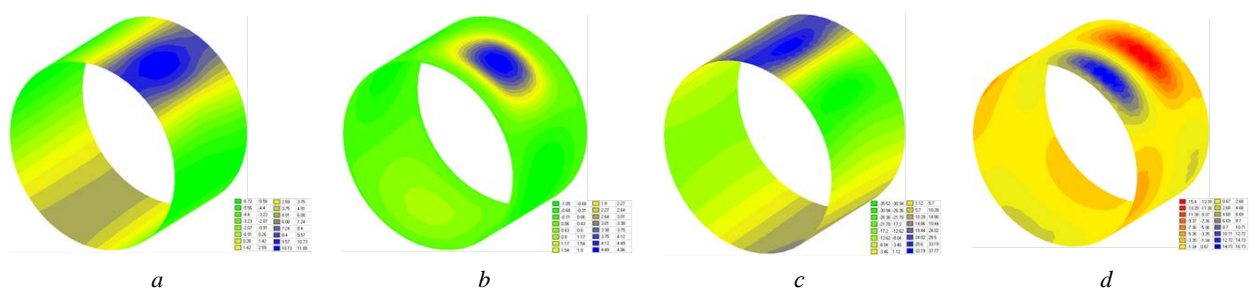

Figure 3 – Bending moments in the prefabricated lining structure of the sewer tunnel reinforcement, kN·m: *a* – in MX direction; *b* – in MY direction; *c* – in QX direction; *d* – in QY direction

To evaluate the expediency of using the proposed technology, three options have been considered: lining the tunnel reinforcement using reinforced concrete rings with corrosion-resistant coating, lining using SPIRO polyethylene pipes, and lining using fiberglass pipes. The comparison of the indicators in terms of the cost of material is shown in table 3.

Table 3 – Cost of technological solutions for rehabilitating a Ø1840 mm tunnel

Item No. of the rehabilitation method	Description of material	Nominal diameter [DN]	Unit of measurement	Cost per unit* [UAH]
1	Spiro polyethylene pipe	1600	rm	29300.00
2	Fiberglass pipe	1600	rm	28400.00
3	Reinforced concrete rings with corrosion-resistant coating	1440	rm	9800.00
*prices are stated per 1 running meter as of November 2018				

In conclusion, it should be noted that the application of the method proposed by the authors from the standpoint of saving material in comparison with analogues is almost three times more cost-effective than the use of polyethylene or fiberglass pipes.

**Conclusions.** In the course of the performed research the following results were obtained.

1. A review was performed of the causes of failures in smooth operation of sewer tunnels;
2. Using the expert evaluation method, it was found that most failures of reinforced concrete sewer tunnels followed by their collapses occur in the areas of their junction to the inspection shafts and stilling pools.
3. As a result of the research performed, an economically and technically efficient technology was developed for rehabilitating sewer tunnels at their junctions to inspection shafts (using lining for reinforcement made of reinforced concrete elements with corrosion-resistant coating).
4. When comparing rehabilitation options involving various materials, it is noted that the proposed rehabilitation method is more economically viable than those using polyethylene or fiberglass lining elements.

**Д. Ф. Гончаренко, А. И. Алейникова, А. В. Убийвовк**

Харьков ұлттық құрылыс және сәулет университеті, Харьков, Украина

#### **ҚАЛДЫҚТАРМЕН ЖҰМЫС ІСТЕЙТІН КЕН ОРЫНДАРЫНА ҚОСЫЛУ АЛАҒЫНДА КЕПТІРУ ТУННЕЛЬДЕРІН ҚАЙТА ҚҰРУ ӘДІСІН ДАМУ**

**Аннотация.** Ағынды суларды жеткіліксіз қаржыландыру және сарқынды суларды тарату жүйесінің жоғары амортизация жағдайында жұмыс істейтін кәсіпорындар өздерінің техникалық және экономикалық мүмкіндіктері шегінде жұмыс істейді. Кәріз туннельдерін пайдаланудың қиындығы бірқатар факторларға байланысты олардың қалпына келмеуінде. Олардың негізгілері: құрылымдардың жоғары тозуы; құбырдың маңызды тереңдігі; ағымдағы жөндеу жұмыстарын жүргізуге арналған телнұсқалардың болмауы; бақылау біліктері арасындағы қашықтық 1 км дейін жетуі мүмкін; кәріз туннеліндегі агрессивті газ заттарының жоғары концентрациясына байланысты операторлар үшін өлім қаупі. Демек, зерттеудің перспективалық бағыты экономикалық тұрғыдан қалпына келтірудің баламалы технологияларын жасау арқылы олардың ұзақ өмір сүруін арттыру болып табылады, бұл шектеулі қаржыландыру жағдайында олардың тұрақты жұмысын қамтамасыз етеді. Мақалада канализация туннельдерінің пайдалану сенімділігі туралы әдебиеттерге шолу жасалады. Кәріз туннельдерінің істен шығу себептерін зерттеу нәтижелері келтірілген. Ақаулықтың келесі себептері анықталды: агрессивті экологиялық факторлардың әсерінен туннель науасының тозуы; сарқынды сулардың агрессивтілігін жүйелі түрде арттыру; кәріз туннелін салудың аркалы бөлігінің тозуы; қарау біліктерінің, сөндіру камераларының, шахталардың техникалық жағдайы; сарқынды су көлеміндегі айырмашылықтар; туннель өткелінің жанында қарқынды даму; қарау біліктері, ажыратқыш камералары, біліктері бар түйіспелердегі қойма киімі; бойлық профильге сәйкес науаның белгілеріндегі айырмашылықтар. Сараптамалық бағалау әдісін қолдана отырып, төтенше жағдайлардың басты себебі туннельдердің бақылаушы біліктермен түйісетін жерлеріндегі зақымдалғандығы болып табылады. Кәріздік туннельдерді коррозияға қарсы жабыны бар темірбетон сақиналарын қолдана отырып, қарау біліктеріне қосылатын жерлерде қалпына келтірудің жаңа әдісі жасалды. Бұл агрессивті ағынды суларға төзімді, қайта өңделген полимерлі материалдан жасалған туннель төсемінің элементтерін кезең-кезеңмен батыруға негізделген. Алдын ала, туннельді арматуралаудың қалыңдығы жобалық талаптарды ескере отырып анықталады және қалпына келтіру процесінің ұсынылған технологиясын ескере отырып орындалған соңғы элементтерді есептеу нәтижелері бойынша анықталады. Туннельді нығайту құрылымының кернеулі-деформациялық күйін

сандық модельдеу жүргізілді. Туннельді арматуралық төсемнің жобалық схемасы цилиндрлік қабықтың фрагменті болып табылады. Шекаралық шарттар бойлық бағытта (канализация туннелінің осі бойымен) жеке түйіндердегі байланыс түрінде қабылданады, сонымен қатар арматура құрылымы мен кәдімгі сызықты-серпімді орта арасындағы өзара әрекеттесу жағдайларына сәйкес келетін тақтайшаларға арналған серпімді негіз коэффициенттері қабылданады. Бақылау біліктеріне жақын жерлерде канализациялық туннельдерді қалпына келтіру үшін ұсынылған әдісті қолдану орындылығы ұсынылған және негізделген. Осы әдісті қолдану арқасында қарастырылған басқа нұсқалармен салыстырғанда қаржы ресурстарының құнын үнемдеуге қол жеткізілді.

**Түйін сөздер:** кәріз туннелі, тозуы, тексеру білігі, коррозия, қалпына келтіру әдісі

**Д. Ф. Гончаренко, А. И. Алейникова, А. В. Убийвовк**

Харьковский национальный университет строительства и архитектуры, Харьков, Украина

### **РАЗРАБОТКА МЕТОДА ВОССТАНОВЛЕНИЯ КАНАЛИЗАЦИОННЫХ ТОННЕЛЕЙ В МЕСТАХ ПРИМЫКАНИЯ К СМОТРОВЫМ ШАХТАМ**

**Аннотация.** В условиях недостаточного финансирования отрасли канализационного хозяйства и высокого амортизационного износа распределительной системы водоотведения эксплуатирующие предприятия осуществляют свою деятельность на пределе своих технических и экономических возможностей. Сложность эксплуатации канализационных тоннелей заключается в их неремонтопригодности ввиду ряда факторов. Основными из них являются: высокая степень технического износа конструкций; значительная глубина заложения трубопроводов; отсутствие дублирующих распределительных линий для осуществления текущего ремонта; расстояние между смотровыми шахтами может достигать до 1 км; смертельная опасность для эксплуатирующих специалистов из-за высокой концентрации веществ агрессивной газовой среды канализационного тоннеля. Следовательно, перспективным направлением исследований является повышение их долговечности путем разработки альтернативных технологий ремонта с экономической точки зрения, что позволит обеспечить их устойчивое функционирование в условиях ограниченного финансирования. В работе выполнен обзор литературных источников относительно повышения эксплуатационной надежности канализационных тоннелей. Представлены результаты исследования причин отказа функционирования канализационных тоннелей. Установлены следующие причины отказа: износ лотка тоннеля под действием агрессивных факторов среды эксплуатации; систематическое увеличение агрессивности сточных вод; износ сводовой части конструкции канализационного тоннеля; техническое состояние смотровых шахт, камер гашения, шахтам; перепады в объемах сточных вод; интенсивная выработка вблизи трассы прохождения тоннеля; износ свода в местах примыкания к смотровым шахтам, камерам гашения, шахтам; перепады отметок лотка согласно продольного профиля. С использованием метода экспертных оценок установлено, что основной причиной возникновения аварийных ситуаций является повреждение сводовой части тоннелей в местах их примыкания к смотровым шахтам. Разработан новый метод восстановления канализационных тоннелей в местах их примыкания к смотровым шахтам с использованием железобетонных колец с антикоррозийным покрытием. Он основывается на поэтапном погружении элементов обделки тоннеля, выполненного из вторичного полимерного материала стойкого к агрессивной канализационной среде. Предварительно толщина обделки усиления тоннеля назначается с учетом конструктивных требований и уточняется по результатам расчета методом конечных элементов, выполненного с учетом предполагаемой технологии процесса восстановления. Проведено численное моделирование напряженно-деформированного состояния конструкции усиления туннеля. Расчетная схема обделки усиления тоннеля представляет собой фрагмент цилиндрической оболочки. Граничные условия приняты в виде связей в отдельных узлах в продольном направлении (вдоль оси канализационного тоннеля), а также коэффициентов упругого основания для пластин, соответствующих условиям взаимодействия конструкции усиления с условной линейно-упругой средой. Представлены и обоснованы целесообразность использования предложенного метода восстановления канализационных тоннелей в местах их примыкания к смотровым шахтам. Благодаря использованию такого метода достигается экономия затрат финансовых ресурсов, в сравнении с другими рассмотренными вариантами.

**Ключевые слова:** канализационный тоннель, износ, смотровая шахта, коррозия, метод восстановления.

#### **Information about author:**

Goncharenko Dmitriy, Doctor of Technical Sciences, Professor, Department of building technology, Kharkiv National University of Construction and Architecture, Kharkiv, Ukraine; gonch@kstuca.kharkov.ua; <http://orcid.org/0000-0003-1278-0895>

Aleinikova Alevtyna, PhD, Assistant, Department of building technology, Kharkiv National University of Construction and Architecture, Kharkiv, Ukraine; alevtynaal222@gmail.com; <http://orcid.org/0000-0002-2486-4263>

Ubiivovk Artem, V PhD, Associate Professor, Department of Geotechnics and Underground Constructions, Kharkiv National University of Construction and Architecture, Kharkiv, Ukraine; [guartv@gmail.com](mailto:guartv@gmail.com); <http://orcid.org/0000-0001-5319-9429>

## REFERENCES

- [1] Korinko Y.V. (2012) Development Program of the Utility Enterprise Kharkivvodokanal until 2026 [Programma razvitiya KP Kharkovvodokanal do 2026 goda]. HVK, Ukraine (in Russ.).
- [2] Aleynikova A.I., Volkov V.M., Goncharenko D.F., Zubko H.H., Starkova O.V. (2017) Methodological foundations of increasing the operational resource of underground engineering networks [Metodolohichni osnovy podovzheniy ekspluatatsiynoho resursu pidzemnykh inzhenernykh merezh]. Rarities of Ukraine, Kharkiv (in Ukr.).
- [3] Bondarenko D.O., Bulhakov V.V., Harmash O.O., Goncharenko D.F., Pilihran S.S. (2018) Sewer tunnels in Kharkov: QUO VADIS? [Kanalizatsiyini tuneli Kharkova: QUO VADIS?]. Rarities of Ukraine, Kharkiv (in Ukr.).
- [4] Goncharenko D., Aleinikova A., Volkov V., Zabelin S. (2016) Research into the factors which influence efficiency of the water supply networks reconstruction by the «Berstlining» technology. Eastern-European Journal of Enterprise Technologies. Vol. 6. P. 21-28.
- [5] Aleinikova A. (2015) Methods for evaluating the economic efficiency of water supply lines restoration based on the findings of teleinspection. Actual Problems of Economics. Vol. 182. P. 224-229.
- [6] Pantieliieva N., Mishchenko S., Pantieliieva K. (2019) The financial mechanism for providing investment lending to the economy of Ukraine with the participation of international financial institutions // Bulletin of national academy of sciences of the Republic of Kazakhstan. 2019. Vol. 6, N 380. P. 141-153. ISSN 2518-1467 (Online), ISSN 1991-3494 (Print). <https://doi.org/10.32014/2019.2518-1467.156>
- [7] Artemenko O. V., Honcharuk L. Yu., Kachur V. O., Lytvyn N. A. Environmental protection under the legislation of the Ukraine and the republic of Poland: a comparative analysis of the main features n. 2019. Vol. 6, N 382. P. 178-183. ISSN 2518-1467 (Online), ISSN 1991-3494 (Print). <https://doi.org/10.32014/2019.2518-1467.160>
- [8] Roscher H. (2015) Rehabilitation von Rohrleitungen Sanierung und Erneuerung von Verund Entsorgungsnetzen Weiterbildendes. Weimar, Weiterbildendes Studium Wasser und Umwelt, Germany.
- [9] Körkemeyer K. (2015) State-of-the-art sewer construction using precast elements. Qualitätssicherung und Fehlervermeidung. Vol. 2. P. 80-83.
- [10] Praetorius S., Schöber B. (2015) Bentonithandbuch. Ringspaltschmierung für den Rohrvortrieb Bauingenieur-Praxis. Kartoniert Ernst & Sohn, Germany.
- [11] Sterling R., Alam S., Allouche E., Condit W., Matthews J., Downey D. (2015) Studying the Life-cycle Performance of Gravity Sewer Rehabilitation Liners in North America. Procedia Engineering. Vol.165. P. 251-258.
- [12] Jeyapalan J.K., Gipson B., Biesalski M. (2015) An Evaluation of Trenchless Point Repair Solutions for Pipes of Varying Inner Diameter and Offset Joints, Pipelines, USA.
- [13] Porjadin V.I. (2014) Ecosystem groundwater resources of Kazakhstan: assessment methodology. [Jekosistemnye resursy podzemnykh vod Kazahstana: metodologiya ocenki]. News of the National Academy of Sciences of the Republic of Kazakhstan. Series of Geology and Technical Sciences. N 5. P. 47-57.
- [14] Wilson D., Filion Y., Moore I. (2017) State-of-the-art review of water pipe failure prediction models and applicability to large-diameter mains. Urban Water Journal. Vol. 14. P. 173-184.
- [15] Bakry I., Alzraiee H., Kaddoura K., Masry M. El., Zayed T. (2017) Condition Prediction for Chemical Grouting Rehabilitation of Sewer Networks. Journal of Performance of Constructed Facilities. Vol. 30. P. 362-375.
- [16] Kaushal V., Young V. (2017) Microbiologically Induced Concrete Corrosion in Sanitary Sewer Systems, Trenchless Technology and Pipe Conference TX, USA.
- [17] Almahakeri M., Moore I., Fam A. (2017) Numerical study of longitudinal bending in buried GFRP pipes subjected to lateral earth movements. Journal of Pipeline Systems Engineering and Practice. Vol. 8, P. 1.
- [18] Information on <http://https://rothenberger.com/de-de/>.
- [19] Information on <http://intelpipe.by/technologies/pipeline-flushing/method>.
- [20] Böhm A. (1993) Betrieb, Instandhaltung und Erneuerung des Wasserrohrnetzes, Vulkan-Verlag.
- [21] Nezat M. (2003) An Innovative Method for Cleaning Large Bore Sewer. New Pipeline Technologies, Security, and Safety, American Society of Civil Engineers.
- [22] Information on <http://jfas.info/index.php/jfas/article/view/148>.
- [23] Bulgakov Y. (2015) Studies of the destruction of structures of a sewer tunnel collector [Issledovaniye protsessa razrusheniya konstruktivnykh kanalizatsionnogo tonnel'nogo kollektora]. Bulletin of construction. Vol. 79. P. 79-84 (In Russ.).
- [24] Goncharenko D.F., Karzhinerova T.I., Zabelin S.A., Kurovskiy I.I. (2010) Preparation for the repair of sewer collectors [Podgotovka k remontu kanalizatsionnykh kollektorov]. Bulletin of construction. Vol. 55. P. 284-290 (in Russ.).
- [25] Zabelin S.A., Aleynikova A.I., Anishchenko A.I. (2018) Application for a patent of Ukraine for the invention of a bucket for cleaning sewer collectors № a 2018 05537 [Zayavka na polucheniye patenta Ukrainy na izobreteniyе № a 2018 05537 «Kovsh dlya ochistki kanalizatsionnykh kollektorov»] (in Ukr.).
- [26] Information on <http://https://habr.com/post/189626/>

**NEWS**

OF THE NATIONAL ACADEMY OF SCIENCES OF THE REPUBLIC OF KAZAKHSTAN

**SERIES OF GEOLOGY AND TECHNICAL SCIENCES**

ISSN 2224-5278

Volume 2, Number 440 (2020), 63 – 71

<https://doi.org/10.32014/2020.2518-170X.32>

UDC 622.24.21.7

**A. Sudakov<sup>1</sup>, A. Dreus<sup>2</sup>, B. Ratov<sup>3</sup>, O. Sudakova<sup>4</sup>, O. Khomenko<sup>1</sup>,  
S. Dziuba<sup>5</sup>, D. Sudakova<sup>1</sup>, S. Muratova<sup>6</sup>, M. Ayazbay<sup>7</sup>**

<sup>1</sup>National TU Dnipro Polytechnic, Department of Underground Mining, Dnipro, Ukraine;<sup>2</sup>Oles Honchar Dnipro National University, Dnipro, Ukraine;<sup>3</sup>Satbayev University, Almaty, Kazakhstan;<sup>4</sup>Pridneprovsk State Academy of Civil Engineering and Architecture, Dnipro, Ukraine;<sup>5</sup>Institute of Geotechnical Mechanics named by N. Poljakov of National Academy  
of Sciences of Ukraine, Dnipro, Ukraine;<sup>6</sup>Caspian University, Almaty, Kazakhstan;<sup>7</sup>M. Kh. Dulaty Taraz State University, Taraz, Kazakhstan.

E-mail: sudakov@ukr.net, dreus@dnu.dp.ua, ratov.bt@gmail.com,

rudana.in.ua@gmail.com, svdzub@i.ua, sudakov@ukr.net, muratova@mail.ru, marat@mail.ru

## **SUBSTANTIATION OF THERMOMECHANICAL TECHNOLOGY PARAMETERS OF ABSORBING LEVELS ISOLATION OF THE BOREHOLES**

**Abstract.** The aim of the work is to improve the thermomechanical absorption insulation technology horizons of drilling wells by the established regularities of change and the substantiation of its regime parameters from the composition and physical-mechanical properties strengthen thermoplastic composite material and, on this basis, development a technological regulation containing recommendations on the manufacture of composites and organizations laying work, designing and isolation of the absorption zones of the washing liquid in the drilling rigs wells. The tasks set were solved by complex method research that contains analysis and synthesis of literary and patent sources, conducting analytical, experimental and industrial research. Experimental processing data was carried out using methods of mathematical statistics. Experimental research is carried out using the provisions of the theory of scientific experiment and theory random processes. The evaluation of the effectiveness of the results was carried out in production conditions.

**Key words:** drilling of boreholes, isolation, absorbing level, melting, backfill materials.

**Topicality.** Drilling of both exploration and exploitation boreholes for exploration of deposits and extraction of minerals in the area of iron-ore and coal basins is conducted in a high degree of development and metamorphism, in strong and fractured rocks [1-10]. Rocks of mined levels are in complicated stressed state [11-18] that during construction of mine workings only complexify the technology of their installation [19-20].

Drilling of boreholes process involves geological complications. The most significant complication is the absorption of flushing water [20]. A significant proportion of the time and funds is spent on drilling of boreholes absorption. Absorption leads to disruption of drilling process mode, boreholes walls integrity, provokes accidents [10-20].

**Analysis of recent research and identification of the unsolved problem.** The works of Basarygin Yu.M., Brezhenenko A.M., Bulatov A.I., Vakhrameev I.I., Vozdvizhenskyi V.I., Volokitenkov A.A., Gaivoronskyi A.A., Dotsenko Yu.G., Ivachev L.M., Kipko E.J., Kotskulich Y.S., Krylov V.I., Kudryashov B.B., Lipatov N.K., Martynenko I.I., Thinyuk M.A., Nikolayeva N.I., Polozov Yu.A., Rafieko I.I., Spichak Yu.N., Sudakov A.K., Stavnya E.M., Titkova N.I., Tana P.M., Yakovlev A.M., Yasov V.G. and

other authors were devoted to research in the area of development of backfill materials and technologies for control of flushing water absorption. Analysis of their research is conducted in works [9].

Drilling of boreholes process involves geological complications. The most common types of complications that disrupted drilling technology were the absorption of drilling fluids. At the same time, annual time in the total balance sheet on drilling had been increased up to 23% and funds up to 10% in a proper way.

In most cases, absorptions isolation is ensured by backfilling of the flushing water absorption materials with solidifying or non-solidifying backfill mixtures by means of creating a waterproof shield in the rock around the borehole.

Insufficiently effective backfill materials are applied for the absorption of flushing water isolation, which are produced on a water base with addition of mineral-bearing or synthetic substances to its composition.

In our view, these materials and technologies have exhausted their possibility of further improvement, so the only way is to develop and apply technologies that based on materials with non-water base and other processes of backfill stone formation for insulation of the boreholes. Such technologies include technologies for creating a backfill stone that are based on the phenomenon of phase transition.

The thermoplastic materials mixes on the base of bitumen, sulfur and synthetic thermo-layers (polyethylene, polypropylene) were applied up to the present moment.

However, the thermoplastic materials due to imperfections in technology, have not found widespread application as backfill materials during absorbing horizons isolation of drilling boreholes.

In order to solve the problem of absorbing levels isolation, it is necessary to find fundamentally new decisions. Therefore, the development of technologies for absorbing level isolation with application of more efficient backfill materials has utmost significance.

This work has a great practical importance. It is dedicated to solving of current scientific problem, which consists in establishing regularities of changing of axial load and rotation velocity during substantiation of mode parameters of effective thermomechanical technology of absorbing levels insulation from average strength limit for uniaxial compression, depending on: composite structure, ratio of components and type of filler; temperature of melting overheating, density, strengthening time and number of melts of backfill thermoplastic compound material.

*Purpose and objectives of the research.* The purpose of work is improvement of thermomechanical technology of absorbing levels isolation of boreholes by means of changing regulations and substantiation of its mode parameters from composition and physical-and-mechanical properties of backfill thermoplastic composite material. As well as development of technological regulation that containing recommendations for composite production and organization of backfilling operations, designing and zones of flushing water absorption isolation in boreholes on this base.

*The idea of work* is in establishment and application of regularities of physical-and-mechanical properties changing and advantages of backfill thermoplastic material for substantiation the mode parameters and to introduce into production effective thermomechanical technology of absorbing levels isolation of boreholes.

**Statement of work.** *The composition is chosen and substantiated due to results of physical-and-mechanical properties research of backfill thermoplastic composite material (TCM) on the base of secondary polyethylene terephthalate (PET) is chosen and reasonable. The technology of TCM production has been developed.*

PET is one of the most common domestic waste. According to statistical data, its volume is up to 20...25% of the total mass of domestic waste.

As the result of analysis of well-known physical-and-mechanical properties of PET, it is possible to apply it as binding material for absorbing levels isolation of boreholes [13-15]. Secondary PET.

Selection, substantiation and examination of the composition of TCM were conducted. Laboratory research allowed to develop an optimal formulation of TCM that protected by patents for an invention of Ukraine [16-18].

During laboratory examinations of physical and mechanical properties of TCM [12-20]:

- the necessity of filler entering into its composition is substantiated. Secondary PET in the molds was collapsed due to radial deep cracks formation. In the fracture of the samples, the structure is highly porous. All samples have a shrinkage phenomenon. Its size did not exceed 25%. On this basis, were made

conclusions concerning to impossibility of PET application as backfill material. Therefore, with the “clean” secondary PET, the work has been stopped;

- type and optimal concentration of filler is determined;
- it is shown that TCM with filler size less than 0.5 mm in ratio 1:1;
- is “abrasive!” material despite the highest degree of wear and tear resistance.

Therefore, in order to the absorption flushing water isolation, it is recommended to apply PET- based TCM with a granulated filler of less than 0.5 mm. Generalized physical-and-mechanical properties are shown in Table 1.

PET-based TCM technology which consists of preparatory stage, production stage of a composite and formation is developed.

During theoretical examinations, approaches to modeling of thermophysical processes of melting and cooling at formation are considered. It is necessary for separation of rational thermophysical parameters of TCM production technology.

The calculations allowed to determine the duration of technological operations for TCM production, as well as the necessary energy costs.

*Development of technology of absorbing levels isolation of boreholes with TCM application.*

The method of absorbing level isolation with PET-based TCM application is developed and substantiated, for implementation of which it is necessary to perform the following technical and logical operations [11]: transportation of TCM to the absorbing level of the borehole, melting of TCM in the borehole and pressing of TCM into absorption channels. The technology of transportation of cylindrical briquettes of TCM along the borehole shaft and possibility of thermomechanical contact melting of TCM in the zone of flushing water removal are substantiated. The method of absorbing levels isolation with PET-based TCM application is defended by Ukrainian patents [1-11].

Technical advantages of the technology are following:

- possibility of TCM melting process management in the control area;
- possibility of TCM lag (jamming) isolation during transportation along the borehole shaft;
- absence of operation for removal of technological equipment from the borehole shaft and as a result, reduction in span time.

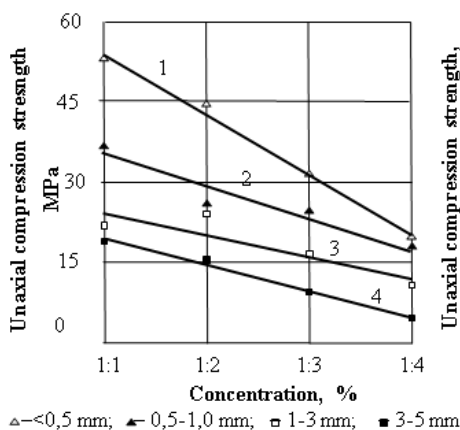

Figure 1 – Dependence of the average uniaxial compression strength from composition and concentration of granulated filler

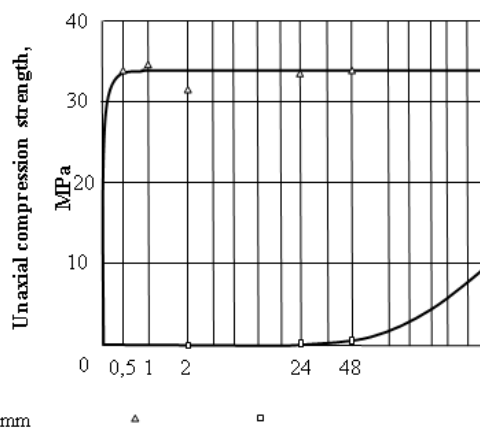

Figure 2 – Dependence of the average uniaxial compression strength on TCM solidifying time of and cement mixture during granulated filler concentration in the ratio of 1:3, gravel size  $< 0.5\text{ mm}</math>$

Table 1 – Generalized physical-and-mechanical properties of TCM

Composition	Density, kg/cu.m	Uniaxial compression strength, MPa	Melting temperature, °C	Spreadability, ms	Hardness coefficient	Abrasion coefficient	Permeability of the sample, cu.cm
PET + Gravel. Ratio 1:1. $d < 0.5\text{ mm}</math>$	1620	52.6	246	16-18	19.8	2.0	absent

The generated heat flux is extending into the body of the TCM briquette due to heat conduction. Under the influence of thermal energy, TCM is heated, and upon reaching the surface temperature, the phase transition value (melting temperature) melts up [18-19]. The molten part of the material is pressed into the porous walls of the borehole 1 due to the pressure that generated by the tool.

In this work we apply the heat-conduction equation to determine the parameters of the heating process in the form of

$$\frac{\partial t}{\partial \tau} = a \frac{\partial^2 t}{\partial y^2}, \quad \tau > 0, \quad 0 \leq y \leq \infty, \quad (1)$$

with initial condition

$$t = t_0, \quad \text{at } \tau = 0 \quad (2)$$

and limiting conditions

$$-\lambda \frac{\partial t}{\partial y} = q_m, \quad \text{at } y = 0, \quad (3)$$

$$t = t_0, \quad \text{at } y \rightarrow \infty, \quad (4)$$

where  $t$  – temperature,  $\tau$  – time,  $a$  – temperature conductivity coefficient,  $y$  – spatial coordinate,  $t = t_0$  – initial temperature,  $\lambda$  – TCM heat conduction coefficient,  $q_m$  – surface flux into heat of the material.

Heat flux on the working surface is determined from

$$q_m = \frac{\mu k_m \pi F D n}{S}, \quad (5)$$

where  $\mu$  – friction coefficient,  $k_m$  – coefficient that taking into account the fraction of friction heat for TCM heating and melting,  $F$  – axial loading,  $D$  – diameter of friction surface,  $S$  – surface area of friction,  $n$  – rotation frequency of the tool.



Figure 3 – Radius of TCM extent in the crack with opening of 30 mm: *a* – backfill stone in the level model, *b* - overhead view

From the solution of task (1) - (4) with the help of Fourier's law  $q = -\lambda \frac{\partial t}{\partial y}$  and condition (5), an expression is obtained, which establish relationships between mode parameters of technological process and parameters of thermophysical processes during tool operation [18-20]

$$F n = \frac{\lambda D}{2 \mu k_m \sqrt{\pi a \tau_f}} (t_f - t_0), \quad (6)$$

where  $\tau_f$  – time of surface heating to melting temperature,  $t_f$  – TCM melting temperature.

The equation of heat balance is applied for determination of thermomechanical drilling velocity in the form of

$$q_m = q_{melt} + q_\lambda, \quad (7)$$

where  $q_{melt}$  –heat for melting of a layer surface of the material with thickness  $d\xi$  for the time  $d\tau$ ;  $q_\lambda$  –heat flow to warm up inner layers of material, determined by Fourier’s law. Heat flux  $q_{melt}$  is defined by the expression

$$q_{melt} = \rho L \frac{d\xi}{d\tau}, \tag{8}$$

where  $L$  – internal melting heat of TCM. The velocity of thermomechanical drilling is defined as  $V=d\xi/\tau d$ .

Therefore, from the equation (7), using the solution of a task (1) – (4) and defining  $\tau_f$  through mode parameters of drilling, expression for the velocity of thermomechanical drilling is received

$$V = \frac{1}{\rho L} \left( \frac{4\mu k_m F n}{D} + \frac{\lambda(t_f - t_0)}{\sqrt{\pi a \tau}} \right). \tag{9}$$

Analyzing (9) at  $\tau \rightarrow \infty$ , we will get a formula for the velocity limit of thermomechanical drilling

$$V_{lim} = \frac{1}{\rho L} \left( \frac{4\mu k_m F n}{D} \right). \tag{10}$$

Average velocity of thermomechanical drilling for the time T we will define as

$$V_{av} = \frac{1}{T} \int_0^T V(\tau) d\tau, \tag{11}$$

where  $T$  – drilling time;  $V(\tau)$  – is determined by equation (10).

After integration (10) on time ranging from 0 to T with taking into account a condition  $\xi=0$  at  $\tau=0$  we will receive expression for drilling depth during period T

$$h = \frac{1}{\rho L} \left( \frac{4\mu k_m F n}{D} T + \frac{2\lambda(t_f - t_0)}{\sqrt{\pi a}} \sqrt{T} \right). \tag{12}$$

Results of performed analysis of calculation algorithm, as well as design dependencies of changing the depth and rate of thermomechanical melting of borehole in time (Figure 6) are presented in the form of alignment chart of dependence of mode parameters on rate of thermomechanical melting of TCM at borehole face. Therefore, during an axial loading of 700 daN and a rotation velocity of 700 min<sup>-1</sup>, the design thermomechanical melting velocity of the instrument volume with a diameter of: 46 mm will be equal to – 1.2 m/h; 59 mm – 1.0 m/h; 76 mm – 0.84 m/h; 93 mm – 0.74 m/h; 269 mm – 0.46 m/h.

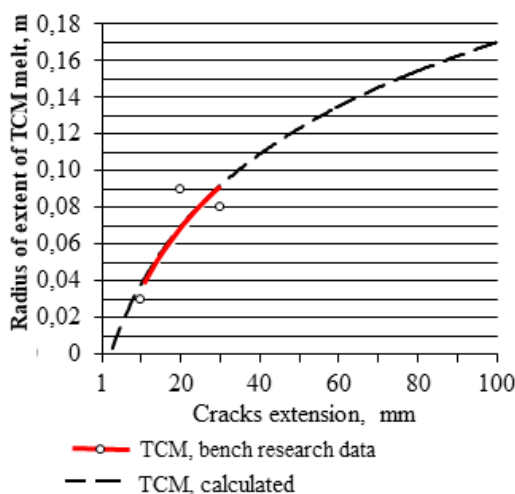

Figure 4 – Dependence of radius of TCM melt distribution on cracks extension for the borehole with a diameter of 59 mm

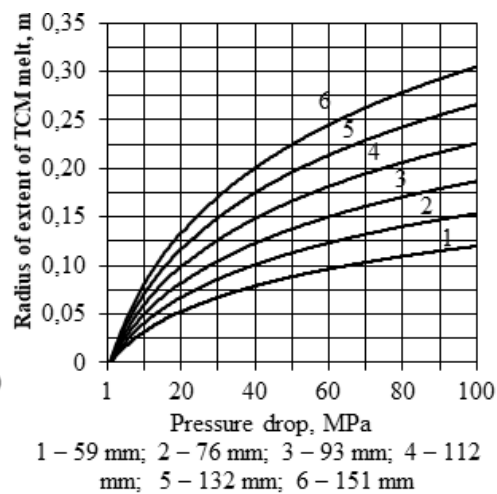

Figure 5 – Dependence of radius of TCM melt distribution on pressure drop in “seam-borehole” system

- developed thermomechanical technology of flushing water absorption isolation with TCM application has made it possible to reduce time consumption in the areas of Havrilovka village up to 15 h, Romanki village – up to 8 h. The total costs at the first site respectively amounted to 24.2 thousand UAH, at the second one is 12.1 thousand UAH (prices of March, 2018) with taking into account the cost of materials, energy inputs and backfilling;

- developed technology allows to isolate absorbing level from borehole space qualitatively, with minimum expenses.

The economic effect of the implementation of the developed method of backfilling in absorbing levels isolation with TCM application is equal to 1.65 - 2.64 million UAH per year with the volume of backfilling operations drive in 100 wells.

**Conclusions.** The main scientific and practical results, conclusions and recommendations or executed research:

1. The theory about conditions under fractured rock the application of water-based backfill mixtures using various mineral-bearing and synthetic substances reached its limit of perfection has been further developed. In recent decades, the work to improve the properties of backfilling materials has been limited to solving local problems, rather than isolation, so the main disadvantage of it is dilution. As a result of water-based backfilling solutions, there is their reduction, significant losses of backfilling materials and time for flushing water isolation, and in general increasing the cost of boreholes by more than 20%. It is possible to reduce these losses by filling the channels with non-diluted in-seam waters by melt of thermoplastic material to form the isolation shell;

It is substantiated that applied thermoplastic materials due to imperfections of technologies, instability of physical-and-mechanical properties, cancerogenity of their components have not found widespread application as backfill materials during absorbing levels isolation of boreholes;

2. The necessary technological parameters of backfilling and dimensions of the isolation shell have been established, which made it possible to substantiate and develop the “Technological Regulation of Absorbing Levels Isolation of PET-based TCM” that acting as a normative document in the production organizations of the State Service of Geology and Subsoil of Ukraine;

3. The results of the complex of theoretical and experimental research that was performed in PhD thesis found practical application during conducting of experimental-industrial implementation of the technology of flushing water isolation of TCM in the conditions of the commercial enterprise of LLC Industrial and Geological Group “Dniprohdrostroï”

**А. Судаков<sup>1</sup>, А. Дреус<sup>2</sup>, Б. Ратов<sup>3</sup>, О. Судакова<sup>4</sup>, О. Хоменко<sup>1</sup>,  
С. Дзюба<sup>5</sup>, Д. Судакова<sup>1</sup>, С. Муратова<sup>6</sup>, М. Ауезбай<sup>7</sup>**

<sup>1</sup>Ұлттық техникалық университеті «Днепровская политехника», Днепр, Украина;

<sup>2</sup>О. Гончар атындағы Днепр Ұлттық университеті, Днепр, Украина;

<sup>3</sup>Satbayev University, Алматы, Қазақстан;

<sup>4</sup>Днепр құрылыс және сәулет академиясы, Днепр, Украина;

<sup>5</sup>Н. С. Полякова атындағы Геотехникалық механика институты

Украина Ұлттық ғылым академиясы, Днепр, Украина;

<sup>6</sup>Каспий университеті, Алматы, Қазақстан;

<sup>7</sup>М. Х. Дулати атындағы Тараз мемлекеттік университеті, Тараз, Қазақстан;

#### **ҰНҒЫЛАРДЫ БҰРҒЫЛАУДЫҢ ГОРИЗОНТТАРЫН ИЗОЛЯЦИЯЛАУДЫҢ ТЕРМОМЕХАНИКАЛЫҚ ТЕХНОЛОГИЯСЫНЫҢ ПАРАМЕТЕРЛЕРІН ПАЙДАЛАНУ**

**Аннотация.** Жұмыстың мақсаты "Ұңғымаларды бұрғылау көкжиектері" термомеханикалық абсорбциялық оқшаулау технологиясын өзгертудің белгіленген заңдылықтары бойынша жетілдіру және оның режимінің параметрлерін беріктендіретін термопластикалық композициялық материалдың құрамы мен физикалық-механикалық қасиеттері бойынша негіздеу және осы негізде композиттер жасау және салу жұмыстарын ұйымдастыру, ұңғымалардың бұрғылау қондырғыларында жуу сұйықтығын сіңіру аймақтарын жобалау және оқшаулау бойынша ұсынымдарды қамтитын технологиялық регламент әзірлеу болып табылады. Қойылған міндеттер әдеби және патенттік көздерді талдау мен қорытуды, аналитикалық, эксперименттік және өнеркәсіптік зерттеулер жүргізуді қамтитын кешенді зерттеу әдісімен шешілді.

Деректерді эксперименттік өңдеу математикалық статистика әдістерін қолдану арқылы жүргізілді. Эксперименталды зерттеу ғылыми эксперимент теориясының ережелерін және кездейсоқ процестер теориясын пайдалана отырып жүргізіледі. Алынған нәтижелердің тиімділігін бағалау өндірістік жағдайларда жүргізілді.

Термопластикалық композициялық материалдан (ТКМ) төгудің құрамы мен физикалық-механикалық қасиеттері бойынша оны пайдалану шарттарын негіздеу және өзгерту заңдылықтарын белгілеу арқылы ұңғымалардың сіңіру деңгейлерін оқшаулаудың термомеханикалық технологиясын жетілдіру. Осы негізде композитті дайындау және ұңғымалардағы жуу суының абсорбция аймақтарын жабу, жобалау және оқшаулау бойынша жұмыстарды ұйымдастыру жөніндегі ұсынымдарды қамтитын технологиялық регламент әзірленеді.

Қойылған міндеттер коммуникацияның кешенді әдісі арқылы шешілді, оған әдеби және патенттік көздерді талдау және қорыту, сондай-ақ аналитикалық, эксперименттік және өнеркәсіптік зерттеулер жүргізу кіреді. Тәжірибелік деректер математикалық статистиканы қолдана отырып, ДК-де өңделді. Эксперименталды зерттеулер ғылыми эксперименттің жалпы теориясын және кездейсоқ процестер теориясын қолдана отырып жүргізілді. Алынған нәтижелердің тиімділігін бағалау өндірістік жағдайларда сынау жолымен жүргізілді.

Байланыс әзірленген және негізделген; ТСМ қолдану мүмкіндігі расталған. Брикеттелген ТЦМ өндіру мүмкіндігі теориялық және эксперименттік түрде көрсетілген. Бастапқы эталондық отын (ПЭТФ) негізінде ТСМ өндіру технологиясы әзірленді. ТКМ өндірісінің ұтымды технологиялық режимдері негізделген. ПЭТ негізінде ТКМ қолдану арқылы жұтылу деңгейін оқшаулау технологиясы әзірленді және негізделген. Сіңіргіш деңгейлерді оқшаулаудың техникалық негіздері жағдайлардың кең ауқымында жылуалмасу процестерін есептеуге мүмкіндік беретін бағдарламалар жиынтығын құру үшін алгоритмі бар балқытуды қолдана отырып әзірленген.

Қайталама ПЭТФ негізінде ТКМ қолдану негізделген және алғаш рет дәлелденген. Екінші рет ПЭТФ қолдануға негізделген ТСМ ұңғымасының проблемалық аймағында термомеханикалық балқыту мүмкіндігі негізделген және дәлелденген. ТСМ термиялық балқыту кезінде жылу алмасу процесін сипаттауға мүмкіндік беретін әлеуетті негізделген және эксперименталды расталған температуралық үлгі одан әрі дамуды алды. Алғаш рет ТЦМ балқытудың термомеханикалық процесінің моды параметрлері мәндерінің оның жылу физикалық қасиеттері мен техникалық сипаттамаларына тәуелділігі анықталды. Бірінші рет ПЭТ негізінде тцм-ның сіңіру қабілеттілігінің жарықшақтардың ашылуынан тәуелділігі анықталды.

Қайталама ПЭТФ негізінде ТКМ қолдана отырып сіңіру деңгейін оқшаулау технологиясын қолдану саласын негіздеу. ПЭТ негізінде ТСМ деңгейін абсорбциялық оқшаулауға арналған технологиялық параметрлерді таңдау бойынша перспективалы ұсыныстарды әзірлеу. Қайталама ПЭТФ негізінде ТКМ сіңіргіш горизонттарын оқшаулаудың принципті жаңа технологияларын әзірлеу. ПЭТФ негізінде ТКМ жасау технологиясын әзірлеу. Зерттеу бағдарламалары мен әдіснамаларын әзірлеу. ТЦМ негізінде ПЭТ оқшаулаудың сіңіргіш горизонттарын сіңіруге арналған технологиялық регламентті әзірлеу.

**Түйін сөздер:** Ұңғымаларды бұрғылау, оқшаулау, сіңіру деңгейі, балқыту, материалдарды жабу.

**А. Судаков<sup>1</sup>, А. Дреус<sup>2</sup>, Б. Ратов<sup>3</sup>, О. Судакова<sup>4</sup>, О. Хоменко<sup>1</sup>,  
С. Дзюба<sup>5</sup>, Д. Судакова<sup>1</sup>, С. Муратова<sup>6</sup>, М. Аязбай<sup>7</sup>**

<sup>1</sup>Национальный технический университет «Днепровская политехника», Днепр, Украина;

<sup>2</sup>Днепровский национальный университет им. О. Гончара, Днепр, Украина;

<sup>3</sup>Satbayev University, Алматы, Казахстан;

<sup>4</sup>Приднепровская академия строительства и архитектуры, Днепр, Украина;

<sup>5</sup>Институт геотехнической механики им. Н. С. Полякова  
Национальной академии наук Украины, Днепр, Украина;

<sup>6</sup>Каспийский университет, Алматы, Казахстан;

<sup>7</sup>Таразский государственный университет им. М. Х. Дулати, Тараз, Казахстан;

## **ОБОСНОВАНИЕ ПАРАМЕТРОВ ТЕРМОМЕХАНИЧЕСКОЙ ТЕХНОЛОГИИ ИЗОЛЯЦИИ ПОГЛОЩАЮЩИХ ГОРИЗОНТОВ БУРОВЫХ СКВАЖИН**

**Аннотация.** Целью работы является совершенствование технологии термомеханической абсорбционной изоляции «Горизонты бурения скважин» по установленным закономерностям изменения и обоснование параметров ее режима по составу и физико-механическим свойствам упрочняющего термопластичного композиционного материала и, на этой основе, разработка технологического регламента, содержащий рекомендации по изготовлению композитов и организации укладочных работ, проектированию и изоляции зон поглощения промывочной жидкости в буровых установках скважин. Поставленные задачи были решены

комплексным методом исследования, содержащим анализ и обобщение литературных и патентных источников, проведение аналитических, экспериментальных и промышленных исследований. Экспериментальная обработка данных проводилась с использованием методов математической статистики. Экспериментальное исследование проводится с использованием положений теории научного эксперимента и теории случайных процессов. Оценка эффективности полученных результатов проводилась в производственных условиях.

Совершенствование термомеханической технологии изоляции поглощающих уровней скважин путем установления закономерностей изменения и обоснования условий ее эксплуатации по составу и физико-механическим свойствам засыпки из термопластичного композиционного материала (ТКМ). На этой основе разрабатывается технологический регламент, содержащий рекомендации по подготовке композита и организации работ по засыпке, проектированию и изоляции зон абсорбции промывочной воды в скважинах.

Поставленные задачи решались с помощью комплексного метода коммуникации, который включает анализ и обобщение литературных и патентных источников, а также проведение аналитических, экспериментальных и промышленных исследований. Экспериментальные данные обрабатывались на ПК с применением математической статистики. Экспериментальные исследования проводились с применением общей теории научного эксперимента и теории случайных процессов. Оценка эффективности полученных результатов проводилась путем испытаний в производственных условиях.

Соединение было разработано и обосновано; Возможность применения ТСМ была подтверждена. Возможность производства брикетированного ТЦМ показана теоретически и экспериментально. Разработана технология производства ТСМ на основе первичного эталонного топлива (ПЭТФ). Обоснованы рациональные технологические режимы производства ТКМ. Разработана и обоснована технология изоляции уровня поглощения с применением ТКМ на основе ПЭТ. Технические основы изоляции поглощающих уровней разработаны с применением плавки с алгоритмом для создания набора программ, позволяющих рассчитывать процессы тепломассообмена в широком диапазоне условий.

Применение ТКМ на основе вторичного ПЭТФ было обосновано и доказано впервые. Обоснована и доказана возможность термомеханического плавления в проблемной зоне скважины ТСМ, основанной на применении вторичного ПЭТФ. Потенциально обоснованная и экспериментально подтвержденная температурная модель, позволяющая описать процесс теплообмена при термическом плавлении ТСМ, получила дальнейшее развитие. Впервые установлена зависимость значений модовых параметров термомеханического процесса плавления ТЦМ от его теплофизических свойств и технических характеристик. Впервые установлена зависимость проникающей способности ТЦМ на основе ПЭТ от раскрытия трещин от уровня поглощения.

Обоснование области применения технологии изоляции уровня поглощения с применением ТКМ на основе вторичного ПЭТФ. Разработка перспективных рекомендаций по выбору технологических параметров для абсорбционной изоляции уровня ТСМ на основе ПЭТ. Разработка принципиально новых технологий изоляции поглощающих горизонтов ТКМ на основе вторичного ПЭТФ. Разработка технологии изготовления ТКМ на основе ПЭТФ. Разработка исследовательских программ и методологий. Разработка технологического регламента для поглощения поглощающих горизонтов изоляции ПЭТ на основе ТЦМ.

**Ключевые слова:** бурение скважин, изоляция, поглощающий уровень, плавка, засыпка материалов.

#### **Information about authors:**

Sudakov Andrey Konstantinovich, National TU Dnipro Polytechnic, Department of Underground Mining, Dnipro, Ukraine; sudakov@ukr.net; <https://orcid.org/0000-0003-2881-2855>

Dreus Andrey Yulevich, Oles Honchar Dnipro National University, Department of Fluid Mechanics and Energy and Mass Transfer, Dnipro, Ukraine; dreus@dnu.dp.ua; <https://orcid.org/0000-0003-0598-9287>

Ratov Boranbay Tovbasarovich, Satbayev University, Almaty, Kazakhstan; ratov.bt@gmail.com; <https://orcid.org/0000-0003-4707-3322>

Sudakova Oksana Ivanovna, Pridneprovsk State Academy of Civil Engineering and Architecture, Department of Economics and Entrepreneurship, Dnipro, Ukraine; soi2@i.ua; <https://orcid.org/0000-0002-8547-6176>

Khomenko Oleg Evgenievich, National TU Dnipro Polytechnic, Department of Underground Mining, Dnipro, Ukraine; koordi@rudana.in.ua; <https://orcid.org/0000-0001-7498-8494>

Dzuba Serhii, Institute of Geotechnical Mechanics named by N. Poljakov of National Academy of Sciences of Ukraine, Dnipro, Ukraine; svdzuba@i.ua; <http://orcid.org/0000-0002-3139-2989>

Sudakova Diana Andreevna, National TU Dnipro Polytechnic, Department of Underground Mining, Dnipro, Ukraine; sudakov@ukr.net; <https://orcid.org/0000-0002-8676-4006>

Muratova Samal Karimbaevna, Caspian University, Almaty, Kazakhstan; muratova@mail.ru; <https://orcid.org/0000-0002-6805-334X>

Ayazbay Marat Dildabekovich, M. Kh. Dulaty Taraz State University, Taraz, Kazakhstan; marat@mail.ru

## REFERENCES

- [1] Malanchuk Z.R., Moshynskiy V.S., Korniienko V.Y., Malanchuk Y.Z., & Lozynskiy V.H. (2019). Substantiating parameters of zeolite-smectite puff-stone washout and migration within an extraction chamber. *Naukovyi Visnyk Natsionalnoho Hirnychoho Universytetu*, (6), 11-18. <https://doi.org/10.29202/nvngu/2019-6/2>
- [2] Khomenko O., Kononenko M., & Lyashenko V. (2019). Safe Mining of Granites at the Manganese Ore Deposits of Ukraine. *Bezopasnost' Truda v Promyshlennosti*, (1), 53-61. <https://doi.org/10.24000/0409-2961-2019-1-53-61>
- [3] Dychkovskiy R.O., Lozynskiy V.H., Saik P.B., Petlovanyi M.V., Malanchuk Ye.Z., & Malanchuk Z.R. (2018). Modeling of the disjunctive geological fault influence on the exploitation wells stability during underground coal gasification. *Archives of Civil and Mechanical Engineering*, 18(4), 1183-1197. <https://doi.org/10.1016/j.acme.2018.01.012>
- [4] Dzyubyk A., Sudakov A., Dzyubyk L., Sudakova D. (2019). Ensuring the specified position of multisupport rotating units when dressing mineral resources. *Mining of Mineral Deposits*, 13(4), (2019). 91-98. <https://doi.org/10.33271/mining13.04.091>
- [5] Khomenko O., & Kononenko M. (2018). Safe Development of the Decorative Jaspilites in the Energetically Disturbed Massifs. *Bezopasnost' Truda v Promyshlennosti*, (8), 15-23. <https://doi.org/10.24000/0409-2961-2018-8-15-23>
- [6] Khomenko O., Kononenko M., Myronova I., & Sudakov A. (2018). Increasing ecological safety during underground mining of iron-ore deposits deposits. *Naukovyi Visnyk Natsionalnoho Hirnychoho Universytetu*, (2), 29-38.
- [7] Lozynskiy V., Saik P., Petlovanyi M., Sai K., & Malanchuk Ye. (2018). Analytical Research of the Stress-Deformed State in the Rock Massif Around Faulting. *International Journal of Engineering Research in Africa*, (35), 77-88. <https://doi.org/10.4028/www.scientific.net/JERA.35.77>
- [8] Tyrlych V., & Moisyshyn V. (2019). Predicting remaining lifetime of drill pipes basing upon the fatigue crack kinetics within a pre-critical period. *Mining of Mineral Deposits*, 13 (3), 127-133. <https://doi.org/10.33271/mining13.03.127>
- [9] Petlovanyi M., Lozynskiy V., Saik P., & Sai K. (2019). Predicting the producing well stability in the place of its curving at the underground coal seams gasification. *E3S Web of Conferences*, (123), 01019. <https://doi.org/10.1051/e3sconf/201912301019>
- [10] Yaremichuk R.S., Vozny V.R., Femyak Y.M. (2011). The use of cavitation-pulsation technology to reduce energy consumption when drilling wells. *Oil industry*. (10), 91–93.
- [11] Khomenko O., & Lyashenko V. (2019). Improvement of the Mine Technical Safety for the Underground Workings. *Bezopasnost' Truda v Promyshlennosti*, (4), 43-51. <https://doi.org/10.24000/0409-2961-2019-4-43-51>
- [12] Kovalevs'ka I., Illiashov M., Fomychov V., & Chervatuk V. (2012). The formation of the finite-element model of the system "undermined massif – support of stope". *Geomechanical Processes during Underground Mining*, 73-79. <https://doi.org/10.1201/b13157-13>
- [13] Fedoriv V., Bagriy S., Piatkovska I., Femyak Y., Trubenko A. (2019) Petrophysic model for determin clayness of rocks by the results of complex geophysical researches / *Geoinformatics*. Ukraine. Kyiv. 5 p.
- [14] Falshtynskyy V., Dychkovskyy R., Lozynskyy V., & Saik P. (2012). New method for justification the technological parameters of coal gasification in the test setting. *Geomechanical Processes During Underground Mining*, 201–208. <https://doi.org/10.1201/b13157-35>
- [15] Sudakov A., Dreus A., Kuzin Y., Sudakova D., Ratov B., & Khomenko O. (2019). A thermomechanical technology of borehole wall isolation using a thermoplastic composite material. *E3S Web Of Conferences*, 109, 00098. <https://doi.org/10.1051/e3sconf/201910900098>
- [16] Pivnyak G., Dychkovskiy R., Smirnov A., & Cherednichenko Y. (2013). Some aspects on the software simulation implementation in thin coal seams mining. *Energy Efficiency Improvement of Geotechnical Systems*, 1-10. <https://doi.org/10.1201/b16355-2>
- [17] Vytyaz O., Chudiy I., Mykhailiuk V. (2015). Study of the effects of drilling string eccentricity in the borehole on the quality of its cleaning (Book Chapter). *New Developments in Mining Engineering 2015: Theoretical and Practical Solutions of Mineral Resources Mining*, P. 591-595.
- [18] Mukhamedzhanov M.A., Sagin Jay, Kazanbaeva L.M., Nurgazieva A.A. Challenging issues of fresh water within the territory of east Kazakhstan and adjacent areas of central Kazakhstan / *News of the national academy of sciences of the republic of Kazakhstan series of geology and technical sciences / ISSN 2224-5278*. Vol. 2, N 434 (2019). P. 15–20. <https://doi.org/10.32014/2019.2518-170X.33>
- [19] Sabraliev N., Abzhapbarova A., Nugymanova G., Taran I., Zhanbirov Zh. Modern aspects of modeling of transport routes in Kazakhstan / *News of the national academy of sciences of the republic of Kazakhstan series of geology and technical sciences / ISSN 2224-5278*. Vol. 2, N 434 (2019), P. 62–68. <https://doi.org/10.32014/2019.2518-170X.39>
- [20] Baibatsha A.B., Suping Peng, Satibekova S.B. Estimation of the physical-mechanical properties of the rocks on the degree of coal metamorphism / *News of the national academy of sciences of the republic of Kazakhstan series of geology and technical sciences / ISSN 2224-5278*. Vol. 1, N 433 (2019), P. 187–194. <https://doi.org/10.32014/2019.2518-170X.23>

**NEWS**

OF THE NATIONAL ACADEMY OF SCIENCES OF THE REPUBLIC OF KAZAKHSTAN

**SERIES OF GEOLOGY AND TECHNICAL SCIENCES**

ISSN 2224-5278

Volume 2, Number 440 (2020), 72 – 80

<https://doi.org/10.32014/2020.2518-170X.33>

UDC 625.8:624.131.52(571.1)

MRNTI:

**V. N. Efimenko<sup>1</sup>, S. V. Efimenko<sup>1</sup>, B. B. Teltayev<sup>2</sup>, A. V. Sukhorukov<sup>1</sup>**

<sup>1</sup>Tomsk State University of Architecture and Building, Tomsk, Russia;

<sup>2</sup>JSC “Kazakhstan Highway Research Institute”, Almaty, Kazakhstan.

E-mail: svefimenko80@gmail.com, svefimenko\_80@mail.ru,

bagdatbt@yahoo.com, av\_suhar@mail.ru

**ON THE NEED FOR DIFFERENTIATED ACCOUNT  
OF PROPERTIES OF THE GEOCOMPLEX  
OF TERRITORIES IN PAVEMENTS DESIGN**

**Abstract.** The article presents the results of a comprehensive study of the relationships and regularities that affect the quality of the pavements design for roads of the West Siberian region. It is shown that the properties of clay soils of the subgrade in the area under study determine their composition, which is formed under the influence of the geographical complex characteristic for the region. The original approach to accounting peculiarities of natural and climatic conditions when zoning the territory is reflected in the taxonomic scheme «zone - subzone - road region». For the road areas identified in the II, III and IV road climatic zones the design characteristics of the subgrade soils of the roads and the study area are assigned. Recommended values of clay soil characteristics differ by up to 40% from those recommended by current standards, which indicates the importance and practical value of the results presented in the article.

Representativeness of samples of strength and deformation parameters in clay soils defined for road districts within West Siberia region is confirmed by the volume of tested soil samples (in the order of 1.2 thousand pieces), as well as by using the methods of probability theory and mathematical statistics when analyzing the test results.

A complex of simulation models is offered that accounts specifics of moisture accumulation in seasonally frost-susceptible road structures of West Siberian roads. The complex advances and adds forecast algorithms for spring and fall soil moisture values which were previously suggested by Prof. I.A. Zolotar. Considerably high consistency was found when comparing forecast and experimental values that characterize design soil moisture of capping layer of the subgrade within the locality of type 2 and 3. For the geocomplex of the II road climatic zone the value of linear correlation coefficient is  $r \geq 0.82$ , for the III road climatic zone it is  $r \geq 0.82$ . Within the IV road climatic zone the coefficient value for spring design moisture of silty loam is  $r \geq 0.90$ .

The outcomes of the study in question enabled to refine spread the boundaries of I-II, II-III and III-IV climatic zones; to define 112 road sections within 14 administrative territorial units of West Siberian region; as well as to substantiate design characteristics of the most widespread soil type. The presented recommendations are designed to increase the time between overhauls for the operating road network of West Siberia.

**Key words:** Road, geocomplex, climatic zoning, pavement, subgrade, clay soils, design values of the soil of the capping layer of the subgrade.

**Introduction.** Peculiarities of geocomplex zones features shall be accounted in road design to provide their reliable operation. Worldwide experience in the field of research on the account of the geographical complex features for road design purposes is integrated in standards, regulations and guidelines that are currently effective in the UK [1], PRC [2], the USA [3], FRG [4], Sweden [1], and other countries, including CIS countries (M.N. Guzinsky [5], B.B. Karimov [6], V.P. Koryukov, R.Z. Poritsky [7], B.B. Teltaev [8], and others).

Presently, the road pavement design theory has gained considerable development in studies performed by S.K. Iliopolov [9], V.A. Kulchitsky [10], V.P. Matua [11], A.E. Merzlikin [12],

B.S. Radovsky [13], A.V. Smirnov [14], B.B. Teltaev [15], E.V. Uglovaya [16], etc. It shall be noted that the reliability of the design values of soil parameters used in the currently effective and developed design methods does not always comply with those required by science and practice.

The suggested research results are based on long-term study of water and thermal regime of road subgrade soils of the II, III and IV road climatic zones in the West Siberia region [17,18,19].

In 1963, Prof. N.A. Tsytoich noted that “physical and geographical environment has immense impact on the formation of soils composition and their properties” [20]. This conclusion is validated and advanced by the specialists of M. Lomonosov Moscow State University [21, 22]. The main law of soil science formulated by Prof. V.T. Trofimov [23] may be interpreted as follows: composition and properties of soils, their structure and condition to a considerable extent define their origin, formation history, manner of spatial location, as well as peculiarities of human-induced impact in the developed territories. Based on the above, one may conclude that consideration of specific features of natural and climatic conditions ensures quality of road structures design.

Unfortunately, the road pavement design regulations currently effective in Russia (ODN 218.046-01 and PNST 265-2018) recommend generalized design values of shear properties and elastic moduli of subgrade soil subtypes, and in most cases they are irrespective of the zone location of the designed object.

With the account of the above, studies on composition and properties of clay soils of road subgrades are characterized by scientific novelty, relevance and have practical value.

**Methods.** A network of about 100 road sections for intermittent long-term observations was assigned for the purpose of studying the features of water-heat processes in the road structures of the West Siberia region. Prior to selection of the sections in the territory under study, the stages of design documents analysis, pre-design inspection and technical condition assessment of the object were performed.

Decisions on assigning the basic road sections located in representative natural and climatic conditions for the administrative unit were made on the alternative basis. The selection criteria were compliance of structural and technological solution of the object with the requirements stated in the regulatory documents, access to the operating hydrometeorological station, and vehicle access for visual and instrumental observations irrespective of the season.

When sampling soil monoliths from the base layer on the road section under study, vertical trial holes were made in the road pavement grooves. Monolith and soil samples were taken from the depth of 0.1...0.2 m from the pavement bottom. Laboratory research include definition of grain size composition, natural, relative and optimum moisture content and maximum density, moisture conductivity coefficient, as well as strength parameters of subgrade soil. General elastic modulus, the value of elastic moduli of pavement layers and subgrade were found as a result of plate bearing tests. Standardized methods and equipment were used while testing.

When planning field and laboratory research, preliminary calculations of minimum required amount of samples were made depending on the accuracy factor  $\Delta$ , mean squared deviation  $\sigma$  and confidence coefficient  $P$ . In total, around 900 subgrade soil samples were tested in the laboratory.

**Results.** Laboratory research of grain size composition of clay soil samples taken from the West Siberian road subgrades revealed that silt fractions (0.05-0.005 mm) are contained in the amount up to 82.3% in sandy clay, and in the amount up to 81.6% in loamy clay. Clay fraction content (<0.005 mm) for sandy clays does not exceed 20.3%, and for loamy clays it is no more than 32.3%.

The given values are close to our recently obtained research results for clay soil samples (silt loam) taken from the right bank of the Tom river nearby Loskutovo village. The studied soil has non-homogeneous structure (saturation level = 11.4), it contains 17.9% of sand fraction, 62.6% of silt fraction and 19.5% of clay fraction.

The results of mineralogical composition studies showed that it is quartz (crystalline silica) that prevails in clay soil in the amount of 60.7%, the content of plagioclase is 15.4% and of montmorillonite – 14.5%. The total content of calcium, chlorite, illite and potash feldspar taken together is 3%.

X-ray study of the samples indicated that the dominating clay minerals have mixed-layer non-homogeneous structure with regard to ratio of alternating textures.

In the samples' chemical composition the most dominant are silicon oxides ( $\text{SiO}_2$ ) with 62.8%, aluminum oxides ( $\text{Al}_2\text{O}_3$ ) with 13.5% and iron oxides ( $\text{Fe}_2\text{O}_3$ ) with 5.5%. The samples have neutral  $\text{pH} = 7-8$ . In the light fractions of the samples the dominant positions are taken by quartz (around 70%) and feldspars (20-25%).

The studies of Prof. V.I. Korobkin [13] performed for European Russia showed that the content of silt and clay fractions in the samples is higher than 25 and 50% respectively, which makes a considerable difference from clay soils of West Siberia region. Assessment of mineralogical composition of clay soils indicates that the light fractions are rich in quartz with its percentage higher than 70%, carbonates (calcite) in the amount up to 11.3%, and feldspars (orthoclase) between 7.2 and 10.2%.

The amount of calcedony and rock fragments content in the samples is between 6.4 and 11%. Heavy fractions are rich in ilmenite, magnetite, limonite, leucosene, etc. Hydrous micas, like illite, are dominating in the mineral composition of clay fraction.

Comparison of the given outcomes of clay soils composition studies performed for West Siberia and south of European Russia districts confirms the validity of previous suggestions [20,22,23] that diverse genesis and age of surface deposits and selective weathering processes in mantle rock formation define the features of composition, condition, structure, and texture of surface soil layer material.

Considering the fact that soils composition significantly defines their properties, when designing road structures one should account the diversity of natural and climatic conditions that also affect road subgrade soil composition and characteristics [20].

For that reason, to provide high quality design and ensure the required service life of roads it is necessary to use the complex of design values for soils of subgrade capping layer determined for their location with individual geographical complex, rather than generalized values taken from regulatory documents, which are developed for vast territories.

To increase time between overhauls and life cycle of roads with enhanced heavy-duty road surfacing one requires detailed zoning of the territory obtained in the previous studies on road climatic zones with specification of their boundaries, and a database that includes design values of soils parameters peculiar for the region. Such developments can be exemplified by the effective regulatory documents of Germany, the USA, China, etc.

The map of road climatic zones of West Siberia (figure) region is based on the common ideology described in [17–19], as well as on the studies by Prof. A.I. Yarmolinsky and Prof. V.A. Yarmolinsky [24]. It consists in distinguishing uniform territories with respect to the geocomplex within the administrative boundaries of regions and districts. The suggested approach to the technology of road climatic zoning is substantiated by the argument that the main network of roads located within an administrative unit is represented by a network of roads of regional or district importance.

Unlike the effective standardized zoning in Russia provided by the Code of Regulations (SP 34.13330.2012), the suggested territorial division of West Siberia presents in considerable detail natural and climatic conditions for such taxons as zone, subzone, road district. Each of the zones distinguished in the territory of the Russian Federation occupies a significant area and represents a single geographical unit that includes various enclaves with diverse combination of geographical components. Zoning of the Russian Federation fixed in the regulatory documents does not correspond to the results of long-term studies and fails to provide high quality of road design.

The outcomes of laboratory tests of soil samples taken from the subgrades of West Siberian roads that occupy the II climatic zone revealed that the upper layer of subgrade primarily consists of silt loams (69% of samples taken during field research), with plasticity index  $I_p = 0.02...0.07$ . Variation of the natural moisture content observed in silt loams is  $W_e = 0.14...0.31$ , and in sandy silt loams it is  $W_e = 0.09...0.16$ . It is peculiar that the range of relative humidity variation  $W_{REL}$  for loamy clays is  $0.42...0.69$  and for sandy clays it is  $W_{REL} = 0.40...0.69$ . With respect to the value of liquidity index  $I_L$  the studied soils are divided into loamy clays, from solid to semi-solid, and solid sandy clays. The variation range of porosity ratio for silt loams is  $e_0 = 0.401...0.870$ , and for sandy clays –  $e_0 = 0.370...0.737$ .

In the West Siberian territory located in the III road climatic zone, man-made soils of the subgrade body are represented by silt loams with plasticity index  $I_p = 0.09...0.17$  and by sandy silt loams with

$I_p = 0.04 \dots 0.07$ . The observed values of natural moisture content belong to the following range:  $W_e = 0.11 \dots 0.31$  – for loamy clays and  $W_e = 0.07 \dots 0.22$  for sandy clays. The variation range for relative humidity values are  $W_{REL} = 0.41 \dots 0.75$  for loamy clays and  $W_{REL} = 0.31 \dots 0.55$  for sandy clays. Based on the liquidity index  $I_L$  the following classes are distinguished: loamy clays – solid, semi-solid and of low plasticity, and solid sandy clays. Porosity variation observed for loamy clays is  $e_0 = 0.117 \dots 0.957$  and for sandy clays –  $e_0 = 0.323 \dots 0.707$ .

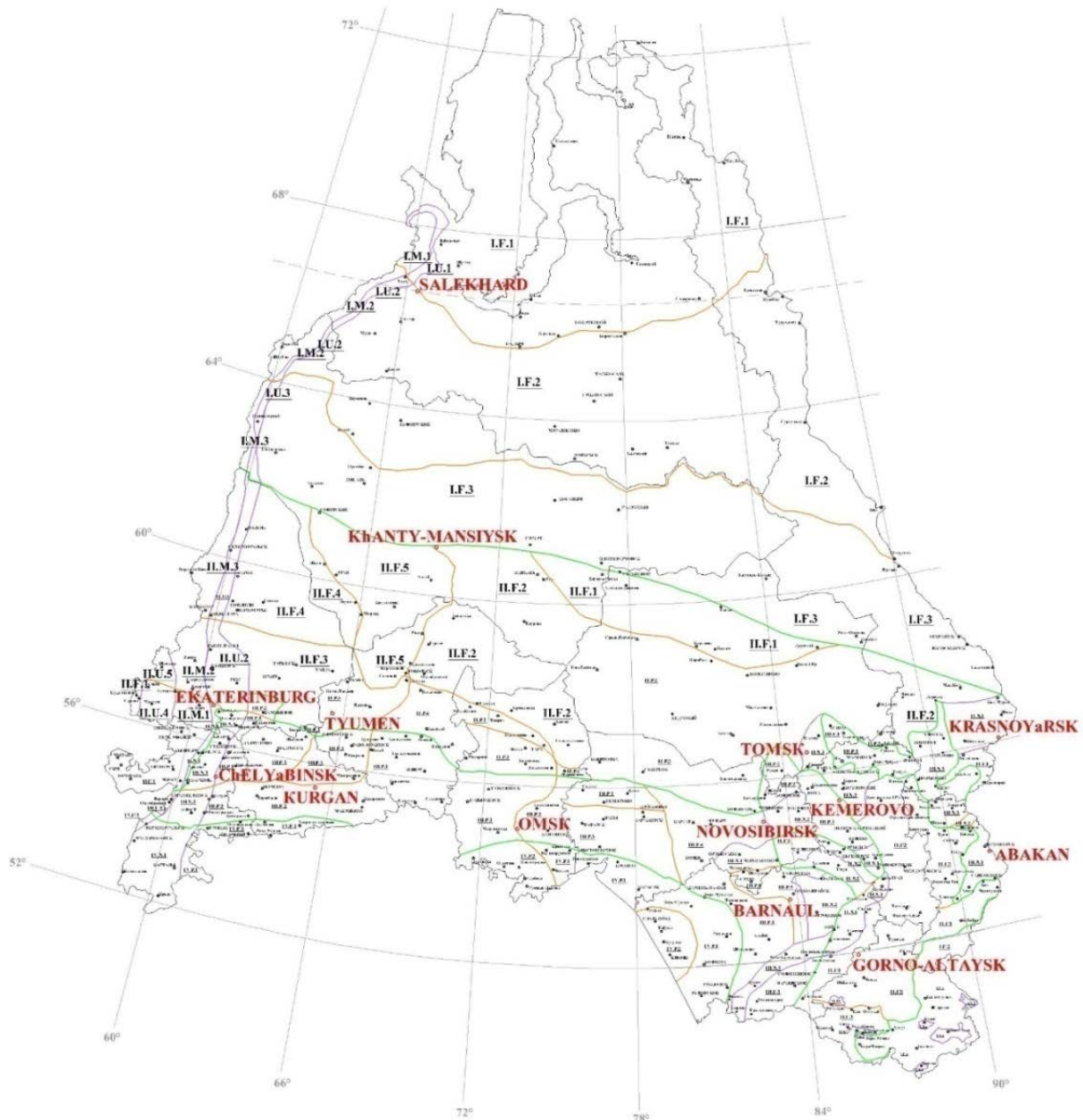

Base map of road climatic zoning of the territory of Western Siberia:

- I, II, III, IV – road-climatic zones based on the results of TSUAB research;
- F, U, M – the subzone by the type of relief (flat, undulated, or mountainous);
- 1–5 – numbers of the road districts.

In the West Siberian territories that belong to the IV road climatic zone the most spread subgrade soils are silt loams with plasticity index of  $I_p = 0.07 \dots 0.17$  and sandy silt loams with plasticity index of  $I_p = 0.06$ . Values of natural moisture content  $W_e$  varied in loamy clays between 0.14 and 0.24, and in sandy

clays it was  $W_e = 0.22$ . The following values of relative humidity were observed:  $W_{REL} = 0.44...0.58$  for loamy clays and  $W_{REL} = 0.62$  for sandy clays. With respect to the liquidity parameter  $I_L$  the following types of soil are distinguished: solid and semi-solid loamy clays and solid sandy clays. The value of porosity ratio  $e_0$  for loamy clays varied between 0.441 and 0.698 and for sandy clays – between 0.338 and 0.411.

Grain size composition of clay soil samples showed that the content of silt fraction in clay subgrade soils of the roads of the II climatic zone does not exceed 81.6% for sandy clay and 82.3% for loamy clay. The content of clay fractions in sandy clays is no higher than 10.7% and 28.6% in loamy clays. Subgrades of road sections that belong to the III climatic zone are mainly represented by clay soils and are characterized by high content of silt fractions – up to 80.8% for sandy clays and up to 80.6% for loamy clays. The percentage of clay fractions reaches 12.2% in sandy clays and 29.7% in loamy clays.

The studied road sections located in the IV road climatic zone with upper layer of subgrade consisting of clay soils are characterized by a decrease in content of silt fractions to 64% for sandy clays and to 77.5% for loamy clays. The amount of clay fractions grew up to 20.3% for sandy clays and up to 32.3% for loamy clays.

Representativeness of samples of clay soils parameters determined for uniform features of territories occupied by the zones of West Siberia is confirmed by the amount of tested soil samples, as well as by the use of probability theory and mathematical statistics methods while analyzing the test results.

**Conclusion.** Based on the performed research a set of recommendations were developed for administrative units of West Siberia region. They contain a complex of design values of the most spread parameters in the region of clay subgrade soils (for example table 1, 2) with the account of new data on regularities and connections that define features of water-heat processes in structures of roads with uniform geocomplex characteristics located within the studied administrative unit.

Table 1 – Estimated values of the characteristics of clay soils of the subgrade of road sections with deep occurrence of the groundwater level (type 1 of area by nature and degree of moisture allocated in the territory of Kemerovo region)

Road districts	Type of road surface	Calculated relative moisture of soil, $W_v$ (u.f.)	Elasticity modulus, $E_{ss}$ (MPa)	Angle of internal friction, $\varphi_{ss}$ (°)	Specific cohesion, $C_{ss}$ (MPa)
II.U.1	A	0.82	15.6	9	0.041
	B	0.79	18.4	10	0.043
II.U.2	A	0.80	22.5	13	0.049
	B	0.79	23.0	13	0.049
II.U.3	A	0.86	22.0	11	0.009
	B	0.82	25.0	12	0.011
II.M.2	A	0.90	19.5	11	0.007
	B	0.86	22.0	11	0.009
II.F.2	A	0.77	22.0	16	0.019
	B	0.76	22.5	17	0.020
III.F.1	A	0.76	30.0	14	0.016
	B	0.71	37.0	16	0.022
III.F.3	A	0.76	30.0	14	0.016
	B	0.71	37.0	16	0.022
III.U.1	A	0.75	32.0	14	0.017
	B	0.70	38.5	16	0.023

Note: A – advanced coatings of capital type; B – advanced lightweight coatings

Table 2 – Values of the calculated characteristics of the clay soil (silty loam) for the road district III.U.2 allocated in the territory of Novosibirsk region

Hydraulic conductivity coefficient, $K_l$ (cm <sup>2</sup> /h)	The level of ground or surface water from the top of the subgrade, $H_w$ (m)	Calculated values of soil indicators			
		Calculated relative moisture of soil, $W_r$ (u.f.)	Elasticity modulus, $E_{ss}$ (MPa)	Angle of internal friction, $\varphi_{ss}$ (°)	Specific cohesion, $C_{ss}$ (MPa)
1.0	0.5	0.76	24	14.2	0.051
	1.0	0.69	28	17.0	0.055
	1.5	0.61	33	21.2	0.061
	2.0	0.58	37	24.0	0.065
	2.5	0.56	38	25.2	0.068
1.5	0.5	0.77	24	13.7	0.050
	1.0	0.70	27	16.6	0.054
	1.5	0.62	33	21.0	0.060
	2.0	0.58	37	23.9	0.065
	2.5	0.56	38	25.2	0.068
2.0	0.5	0.79	23	13.3	0.050
	1.0	0.71	27	16.3	0.054
	1.5	0.62	32	20.8	0.060
	2.0	0.58	36	23.8	0.065
	2.5	0.56	38	25.1	0.067

Continuation of the table 2

Hydraulic conductivity coefficient, $K_l$ (cm <sup>2</sup> /h)	The level of ground or surface water from the top of the subgrade, $H_w$ (m)	Calculated values of soil indicators			
		Calculated relative moisture of soil, $W_r$ (u.f.)	Elasticity modulus, $E_{ss}$ (MPa)	Angle of internal friction, $\varphi_{ss}$ (°)	Specific cohesion, $C_{ss}$ (MPa)
2.0	0.5	0.79	23	13.3	0.050
	1.0	0.71	27	16.3	0.054
	1.5	0.62	32	20.8	0.060
	2.0	0.58	36	23.8	0.065
	2.5	0.56	38	25.1	0.067
2.5	0.5	0.80	23	13.0	0.049
	1.0	0.71	26	16.0	0.053
	1.5	0.62	32	20.6	0.060
	2.0	0.58	36	23.7	0.065
	2.5	0.56	38	25.1	0.067
3.0	0.5	0.81	22	12.7	0.049
	1.0	0.72	26	15.7	0.053
	1.5	0.63	32	20.5	0.060
	2.0	0.58	36	23.6	0.065
	2.5	0.56	38	25.1	0.067

Considerable differences were found in comparison of the values recommended by the regulatory documents ODN 218.046-01 and PNST 265-2018 with the substantiated standardized design values of clay subgrade soils parameters for road districts under study. For instance, the value of elastic modulus for silt loam given in the regulatory documents is higher than the actual one by 25-40% depending on the

relative moisture of the soil. At the same time, the values of angle of internal friction are lower than those experimentally obtained by 5-30%, and the value of specific cohesion is lower by 10-45%. The given research results indicate the ability to increase time between overhauls for road structures.

**В. Н. Ефименко<sup>1</sup>, С. В. Ефименко<sup>1</sup>, Б. Б. Телтаев<sup>2</sup>, А. В. Сухоруков<sup>1</sup>**

<sup>1</sup>Томск мемлекеттік сәулет-құрылыс университетінің, Томск, Ресей;  
<sup>2</sup>«Қазақстан жол ғылыми-зерттеу институты» АҚ, Алматы, Қазақстан

### **ЖОЛ ТӨСЕМЕЛЕРІН ЖОБАЛАУ КЕЗІНДЕ САЗДЫ ТОПЫРАҚТАРДЫҢ ҚАСИЕТТЕРІН САРАЛАП ЕСЕПKE АЛУ ҚАЖЕТТІЛІГІ ТУРАЛЫ**

**Аннотация.** Мақалада Батыс Сібір аймағындағы автомобиль жолдарының жол төсемесін жобалау сапасына ықпал ететін байланыстар мен заңдылықтарды кешенді зерттеу нәтижелері келтірілді. Зерттеу аумағындағы жер төсемінің сазды топырақтарының қасиеттері аймаққа тән географиялық кешен белгілерінің әсерінен қалыптасатын құрамын анықтайды. «Аймақ - кіші аймақ - жол ауданы» таксономиялық схемасында аумақты аудандастыру кезіндегі табиғи-климаттық жағдайлардың ерекшеліктерін есепке алудың ерекше тәсілі көрсетілген. II, III және IV жол-климаттық аймақтарда бөлінген жол аудандары үшін автомобиль жолдарының жер төсемі топырақтарының, зерттеу аумағының есептік сипаттамалары тағайындалды. Сазды топырақ сипаттамаларының ұсынылатын мәндері 40% дейін ұсынылған қолданыстағы нормалардан ерекшеленеді, бұл мақалада ұсынылған нәтижелердің маңыздылығы мен тәжірибелі құндылығын көрсетеді.

Батыс-Сібір аймағындағы аймақтар шегіндегі жол аудандарының аумақтары үшін белгіленген сазды топырақтардың беріктік және деформациялық сипаттамаларының мәндерін іріктеудің репрезентативтілігі сынақ нәтижелерін өңдеу кезінде ықтималдықтар теориясы мен математикалық статистика әдістерін қолдану арқылы сыналған топырақ сынамаларының көлемімен (шамамен 1.2 мың) расталған.

Бұған дейін профессор И. А. Золотарь ұсынған топырақтың күзгі және көктемгі ылғалдылығының шамаларын болжау алгоритмдерін дамытатын және толықтыратын Батыс-Сібір өңірінің автомобиль жолдарының маусымдық қатып қалған жол құрылымдарында жинақталу ерекшеліктерін ескеретін имитациялық модельдер кешені ұсынылды. Жергілікті жердің 2 және 3 типтері жағдайында жер төсемесінің жұмыс қабаты топырағының есептік ылғалдылығын сипаттайтын болжамды және эксперименталдық белгіленген шамаларды салыстыру нәтижелері сәйкестіктің жеткілікті жоғары дәрежесін куәландырады. II геокешен үшін жол-климаттық аймақтар (ЖКА) үшін  $r \geq 0.82$  корреляция сызықтық коэффициентінің мәні, III ЖКА үшін  $r \geq 0.82$ . IV ЖКА жағдайында көктемгі есептік ылғалдылыққа арналған шаңды саздақ  $r \geq 0.90$ .

Қарастырылып отырған зерттеулердің нәтижелері I-II, II-III және III-IV жол-климаттық аймақтардың кең таралу шекараларын нақтылауға, Батыс-Сібір аймағының 14 әкімшілік-аумақтық құрылымы шегінде 112 жол ауданын бөлуге мүмкіндік берді. Ұсынылған ұсыныстар Батыс-Сібірде пайдаланылатын автомобиль жолдары желісінің жөнделу аралық мерзімдерін арттыруға бағытталған.

**Түйін сөздер:** автомобиль жолы, геокешен, жол-климаттық аудандастыру, жол төсемесі, жер төсемесі, сазды топырақ, жер төсемесінің жұмыс қабаты топырағының есептік мәні.

**В. Н. Ефименко<sup>1</sup>, С. В. Ефименко<sup>1</sup>, Б. Б. Телтаев<sup>2</sup>, А. В. Сухоруков<sup>1</sup>**

<sup>1</sup>Федеральное государственное бюджетное образовательное учреждение высшего образования «Томский государственный архитектурно-строительный университет», Томск, Россия;  
<sup>2</sup>АО «Казахстанский дорожный научно-исследовательский институт», Алматы, Казахстан

### **О НЕОБХОДИМОСТИ ДИФФЕРЕНЦИРОВАННОГО УЧЁТА СВОЙСТВ ГЛИНИСТЫХ ГРУНТОВ ПРИ ПРОЕКТИРОВАНИИ ДОРОЖНЫХ ОДЕЖД**

**Аннотация.** В статье приведены результаты комплексного изучения связей и закономерностей, влияющих на качество проектирования дорожных одежд автомобильных дорог Западно-Сибирского региона. Показано, что свойства глинистых грунтов земляного полотна на территории исследования определяет их состав, формирующийся под влиянием признаков географического комплекса, характерных для региона. Отражён оригинальный подход к учёту особенностей природно-климатических условий при районировании

территории в таксономической схеме «зона – подзона – дорожный район». Для дорожных районов, выделенных во II, III и IV дорожно-климатических зонах, назначены расчётные характеристики грунтов земляного полотна автомобильных дорог, территории исследования. Рекомендуемые значения характеристик глинистых грунтов до 40% отличаются от рекомендованных действующими нормами, что свидетельствует о важности и практической ценности представленных в статье результатов.

Репрезентативность выборок значений прочностных и деформационных характеристик глинистых грунтов, установленных для территорий дорожных районов в пределах зон в Западно-Сибирском регионе, подтверждена объёмом испытанных проб грунта (около 1.2 тыс.), применением при обработке результатов испытаний методов теории вероятностей и математической статистики.

Предложен комплекс имитационных моделей, учитывающих особенности накопления в сезонно промерзающих дорожных конструкциях автомобильных дорог Западно-Сибирского региона, развивающий и дополняющий алгоритмы прогнозирования величин осенней и весенней влажности грунтов, ранее предложенные профессором И.А. Золотарём. Результаты сопоставления прогнозных и экспериментального установленных величин, характеризующих расчётную влажность грунта рабочего слоя земляного полотна в условиях 2 и 3 типов местности, свидетельствует о достаточно высокой степени совпадения. Для геокомплекса II дорожно-климатические зоны (ДКЗ) значение линейного коэффициента корреляции  $r \geq 0.82$ , для III ДКЗ  $r \geq 0.82$ . В условиях IV ДКЗ для весенней расчётной влажности суглинка пылеватого  $r \geq 0.90$ .

Результаты рассматриваемых исследований позволили уточнить распространение (было распространённых) границ I-II, II-III и III-IV дорожно-климатических зон, выделить 112 дорожных районов в пределах 14 административно-территориальных образований Западно-Сибирского региона, обосновать расчётные характеристики наиболее распространённого грунта. Представленные рекомендации направлены на увеличение межремонтных сроков сети эксплуатируемых в Западной Сибири автомобильных дорог.

**Ключевые слова:** автомобильная дорога, геокомплекс, дорожно-климатическое районирование, дорожная одежда, земляное полотно, глинистые грунты, расчётные значения грунтов рабочего слоя земляного полотна.

#### Information about authors:

Efimenko V.N., Doctor of Technical Sciences, Professor of Automobile Roads Department, Tomsk State University of Architecture and Building, Tomsk, Russia; svfimenko80@gmail.com; <https://orcid.org/0000-0001-6080-5482>

Efimenko S.V., Doctor of Technical Sciences, Dean of Road Construction Faculty, Head of Automobile Roads Department, Tomsk State University of Architecture and Building, Tomsk, Russia; svfimenko\_80@mail.ru; <https://orcid.org/0000-0001-7064-1418>

Teltayev B.B., Doctor of Technical Sciences, Professor, Academician of NEA RK, President of JSC “Kazakhstan Highway Research Institute”, JSC “Kazakhstan Highway Research Institute”, Almaty, Kazakhstan; bagdatbt@yahoo.com; <https://orcid.org/0000-0002-8463-9965>

Sukhorukov A.V., Candidate of Technical Sciences, Associated Professor of Automobile Roads Department, Tomsk, Russia; av\_suhar@mail.ru; <https://orcid.org/0000-0001-8778-5418>

#### REFERENCES

- [1] Groney D., Groney P. 1991. *The design and performance of road pavements*. Second edition. McGraw Hill, London. ISBN: 0077074084 (in Eng.).
- [2] JTG J003-86. Highway Natural Zoning Standards. China Communications Press, China, 1986. (in Chin.).
- [3] JTG D20-2017. Design Specification for Highway Alignment. China Communications Press, China, 2018. (in Chin.).
- [4] RStO 11. Richtlinien für die Standartisierung des Oberbaues von Verkehrsflächen. Beuth Verlag GmbH, Berlin, 2011. (in Germ.).
- [5] Gudzinskii M.N. 1975. *Justification of the design characteristics of the subgrade soil of roads in relation to the natural conditions of the Ukrainian SSR*. Kharkiv (in Russ.).
- [6] Karimov B.B. 2007. Quality strategy (important parameter, search directions, quality criterion and joint strategy). *Roads of the Community*, 2: 1-11 (in Russ.).
- [7] Poritskii R.Z. 1975. *Instructions for assigning design indicators of subgrade soils in the conditions of the Byelorussian SSR*. Minsk. (in Russ.).

- [8] Teltayev B.B., Suppes E.A. 2019. Temperature and moisture in a highway in the south of Kazakhstan, *Transportation Geotechnics*, 21. 100292. DOI: 10.1016/j.trgeo.2019.100292 (in Eng.).
- [9] Iliopolov S.K. 1999. *Development of the basics of integrated accounting of dynamic effects for the calculation and design of pavement*. Rostov-on-Don (in Russ.).
- [10] Kul'chitskii V.A., Makagonov V.A., Vasil'ev N.B. et al. 2002. *Airfield pavements. Modern vision*. Physics and Mathematics Literature, M. (in Russ.).
- [11] Matua V.P. 2002. *Investigation of the stress-strain state of road structures with the account of their inelastic properties and spatial loading*. Rostov-on-Don (in Russ.).
- [12] Merzlikin A.E., Kapustnikov N.V. 2011. Modeling of elastic homogeneous and bilayer half-space applicable to problems of road pavement design by the finite elements method. *Roads and bridges* 1: 63-72 (in Russ.).
- [13] Radovskij B.S., Suprun A.S., Kozakov I.I. 1989. *Pavements design for heavy vehicles traffic roads*. Budivel'nik, Kiev (in Russ.).
- [14] Smirnov A.V. 1991. *Theoretical and experimental studies of the performance of flexible pavements*. M. (in Russ.).
- [15] Iskakbayev A.I., Teltayev B.B., Oliviero R., Estayev K. 2018. A new simple damage accumulation model for predicting of an asphalt concrete cyclic strength, *News of the National Academy of Sciences of the Republic of Kazakhstan, Series of Geology and Technical Sciences*, 5: 38-47. DOI: 10.32014/2018.2518-170X.8 (in Eng.).
- [16] Uglova E.V. 2009. *Theoretical and methodological foundations for assessing the residual fatigue life of asphalt concrete road surfaces*. Volgograd (in Russ.).
- [17] Efimenko V.N., Efimenko S.V., Sukhorukov A.V. 2015. Peculiarities of strength and deformability properties of clay soils in districts of Western Siberia, *Advanced Materials in Technology and Construction*, 1698. 070020. DOI: 10.1063/1.4937890 (in Eng.).
- [18] Efimenko V.N., Efimenko S.V., Sukhorukov A.V. 2016. Technology for Assignment of Predicted Behavior of Subgrade Soils in the Design of Road Pavements, *Key Engineering Materials*, 683: 250-255. DOI: 10.4028/www.scientific.net/KEM.683.250
- [19] Efimenko V.N., Efimenko S.V., Sukhorukov A.V. 2018. Features of road-climatic zoning of territories, *MATEC Web of Conferences*, 143. 01012. DOI: 10.1051/mateconf/201714301012
- [20] Cytovich N.A. 1963. *Soil mechanics*. Strojizdat, M. (in Russ.).
- [21] Krivosheeva Z.A., Zlochevskaya R.I., Korolev V.A., Sergeev E.M. 1977. About character of variation for composition and properties of clay rocks in processes of lithogenesis, *Moscow University Geology Bulletin* (in Russ.).
- [22] Sergeev E.M., Golodkovskaya G.A., Ziangirov R.S., Osipov V.I., Trofimov V.T., Sergeev E.M. 1983. *Soil science*. MSU publishing house, M. (in Russ.).
- [23] Trofimov V.T. 1977. *Patterns of spatial changes in the engineering and geological conditions of the West Siberian Plate*. MSU publishing house, M. (in Russ.).
- [24] Ushakov V.V., Yarmolinsky V.A., Dobrov E.M., Goryachev M.G. 2017. Revision of descriptions and calculated properties of road bed soils and asphalt concrete materials upon designing of highway pavements in terms of criteria of residual deformations and fatigue cracking of asphalt concretes, *International Journal of Civil Engineering and Technology*, 8: 1074-1083. (in Eng.).

**NEWS**

OF THE NATIONAL ACADEMY OF SCIENCES OF THE REPUBLIC OF KAZAKHSTAN

**SERIES OF GEOLOGY AND TECHNICAL SCIENCES**

ISSN 2224-5278

Volume 2, Number 440 (2020), 81 – 86

<https://doi.org/10.32014/2020.2518-170X.34>

UDC 622.24

**A. K. Kassenov<sup>1</sup>, A. H. Syzdykov<sup>1</sup>, V. I. Spirin<sup>2</sup>, M. S. Moldabekov<sup>1</sup>, M. S. Bukenova<sup>1</sup>**<sup>1</sup>Satbayev University, Almaty, Kazakhstan;<sup>2</sup>Project Center LLC, Tula, Russia.E-mail: kassenov07@inbox.ru, syzdykov\_su@mail.ru, vispirin@bk.ru,  
moldabekov\_ms@mail.ru, bukenova77@mail.ru**METHODS FOR CALCULATING CAVITATORS  
FOR DEVICES DESIGNED BY SATBAYEV UNIVERSITY  
FOR CLEANING OIL AND GAS WELLS**

**Abstract.** The article says that with long-term exploitation of oil and gas wells, production wells lose design capacity over time, and injection wells lose injectivity. After a certain period of time, these wells undergo repair and restoration work in order to restore the project flow rate and injectivity. One of the reasons for the failure of the wells is the overfilling of the filter zone with products of chemical and mechanical mudding and the deposition of mechanical suspensions in the well sump, as a result of which the productivity of the wells decreases below the permissible limits required by the production regulations.

It is proposed to use special shells designed by Satbayev University for cleaning oil and gas wells using cavitated liquid as a cleaning agent.

A technique is proposed for calculating the cavitators of these devices for oil and gas wells depending on the number of cavitation, the flow rate of the flushing fluid, the hydrostatic pressure of the fluid in the well, and the working pressure of the flushing pump. An example of the calculation of cavitators for the wells of the fields of JSC "Ozenmunaygas" is given.

**Key words:** Well productivity, throttle response, repair work, cavitation, hydrostatic pressure.

With long-term exploitation of oil and gas wells, production wells lose design capacity over time, and injection wells lose injectivity. After a certain period of time, these wells undergo repair and restoration work in order to restore the project flow rate and injectivity. One of the reasons for the failure of the wells is the overfilling of the filter zone with products of chemical and mechanical mudding and the deposition of mechanical suspensions in the well sump, as a result of which the productivity of the wells decreases below the permissible limits required by the production regulations.

At the Department of Petroleum Engineering, Satbayev University, in the course of research work, shells were developed for cleaning geotechnological wells that are used for underground leaching of uranium ores [1,2]. As a cleaning agent, cavitated process water was used. Production tests of these devices have shown their high efficiency [3,4].

Given the positive effect of the use of these shells, the authors recommend the use of these shells for cleaning oil and gas wells.

However, due to the fact that the geological and technical conditions of oil wells are fundamentally different from geotechnological wells (large depths, diameters, used equipment, etc.), there is a need for theoretical studies to calculate certain units of the device for oil and gas wells.

Special devices create cavitation using sound waves in a fluid. Cavitation bubbles, collapsing, give rise to shock waves, which destroy particles of contaminants or separate them from the surface. Thus, the need for hazardous and unhealthy cleaning substances is reduced in many industrial and commercial processes where cleaning is required as a stage of production.

Cavitation number. The cavitation flow is characterized by a dimensionless parameter (cavitation number) [5]:

$$K = \frac{P_0 - P_h}{\left(\frac{\rho v_0^2}{2}\right)} \quad (1)$$

where  $P_0$  is hydrostatic pressure of the oncoming flow, Pa;  $P_h$  is pressure of saturated vapor of a liquid at a certain ambient temperature, Pa;  $\rho$  is the density of the medium, kg/m<sup>3</sup>;  $v_0$  is flow rate at the system inlet, m/s.

The cavitation number can take different values, but cavitation occurs only in the range  $K = 0.1 - 0.6$ . It is known that cavitation occurs when the flow reaches the boundary velocity, when the pressure in the flow becomes equal to the vaporization pressure (saturated vapor). The boundary value of the cavitation criterion corresponds to this speed.

For well conditions, the flow pressure depends on the operating pressure of the pump  $P_p$ , the hydrostatic pressure of the fluid  $P_h$  located in the well, and the pressure loss in the pipelines  $P_l$ , through which the working fluid is transported to the working body, that is:

$$P_0 = P_p - (P_h + P_l) \quad (2)$$

Naturally, the magnitude of the hydrostatic pressure of the fluid  $P_h$  located in the well should be less than the value of the working pressure of the pump and it is determined:

$$P_h = \rho g H \quad (3)$$

where,  $\rho$  is the density of the fluid in the well, kg/m<sup>3</sup>;  $g$  is the acceleration of gravity, m/s<sup>2</sup>;  $H$  is the depth of the well at which hydrostatic pressure is measured, m.

The magnitude of the pressure loss in the pipelines through which the working fluid is transported to the working body can be determined by the method described in [5] and the program developed at the former Department of Technology and Technique for Drilling Wells of KazNRTU named after K. Satbayev [7].

Due to the fact that process water is used as a cleaning agent (possibly heated to clean tar and paraffin deposits), the pressure values of saturated vapor of a liquid at a certain ambient temperature are given in the table below [8].

With an interval of one degree, the pressure (P) of water vapor from the melting point to critical is given. Up to 100 ° C, the table contains the value of P, expressed in kPa and mmHg, above 100 ° C, the P value is indicated only in kPa.

Table 1 – Saturated vapor pressure of water from 0 ° C to 374 ° C

t, °C	P		t, °C	P		t, °C	P	
	kPa	mmHg		kPa	mmHg		kPa	mmHg
0	0.61129	4.585	34	5.3229	39.93	68	28.576	214.3
1	0.65716	4.929	35	5.6267	42.20	69	29.852	223.9
2	0.70605	5.296	36	5.9453	44.59	70	31.176	233.8
3	0.75813	5.686	37	6.2795	47.10	71	32.549	244.1
4	0.81359	6.102	38	6.6298	49.73	72	33.972	254.8
5	0.87260	6.545	39	6.9969	52.48	73	35.448	265.9
6	0.93537	7.016	40	7.3814	55.37	74	36.978	277.4
7	1.0021	7.516	41	7.7840	58.38	75	38.563	289.2
8	1.0730	8.048	42	8.2054	61.55	76	40.205	301.6
9	1.1482	8.612	43	8.6463	64.85	77	41.905	314.3
10	1.2281	9.212	44	9.1075	68.31	78	43.665	327.5
11	1.3129	9.848	45	9.5898	71.93	79	45.487	341.2
12	1.4027	10.52	46	10.094	75.71	80	47.373	355.3
13	1.4979	11.24	47	10.620	79.66	81	49.324	370.0
14	1.5988	11.99	48	11.171	83.79	82	51.342	385.1

15	1.7056	12.79	49	11.745	88.09	83	53.428	400.7
16	1.8185	13.64	50	12.344	92.59	84	55.585	416.9
17	1.9380	14.54	51	12.970	97.28	85	57.815	433.6
18	2.0644	15.48	52	13.623	102.2	86	60.119	450.9
19	2.1978	16.48	53	14.303	107.3	87	62.499	468.8
20	2.3388	17.54	54	15.012	112.6	88	64.958	487.2
21	2.4877	18.66	55	15.752	118.1	89	67.496	506.3
22	2.6447	19.84	56	16.522	123.9	90	70.117	525.9
23	2.8104	21.08	57	17.324	129.9	91	72.823	546.2
24	2.9850	22.39	58	18.159	136.2	92	75.614	567.2
25	3.1690	23.77	59	19.028	142.7	93	78.494	588.8
26	3.3629	25.22	60	19.932	149.5	94	81.465	611.0
27	3.5670	26.75	61	20.873	156.6	95	84.529	634.0
28	3.7818	28.37	62	21.851	163.9	96	87.688	657.7
29	4.0078	30.06	63	22.868	171.5	97	90.945	682.1
30	4.2455	31.84	64	23.925	179.5	98	94.301	707.3
31	4.4953	33.72	65	25.022	187.7	99	97.759	733.3
32	4.7578	35.69	66	26.163	196.2	100	101.32	760.0
33	5.0335	37.75	67	27.347	205.1			

t, °c	P, kPa	t, °c	P, kPa	t, °c	P, kPa	t, °c	P, kPa
100	101.32	147	438.67	194	1368.0	241	3403.9
101	104.99	148	450.75	195	1397.6	242	3463.9
102	108.77	149	463.10	196	1427.8	243	3524.7
103	112.66	150	475.72	197	1458.5	244	3586.3
104	116.67	151	488.61	198	1489.7	245	3648.8
105	120.79	152	501.78	199	1521.4	246	3712.1
106	125.03	153	515.23	200	1553.6	247	3776.2
107	129.39	154	528.96	201	1586.4	248	3841.2
108	133.88	155	542.99	202	1619.7	249	3907.0
109	138.50	156	557.32	203	1653.6	250	3973.6
110	143.24	157	571.94	204	1688.0	251	4041.2
111	148.12	158	586.87	205	1722.9	252	4109.6
112	153.13	159	602.11	206	1758.4	253	4178.9
113	158.29	160	617.66	207	1794.5	254	4249.1
114	163.58	161	633.53	208	1831.1	255	4320.2
115	169.02	162	649.73	209	1868.4	256	4392.2
116	174.61	163	666.25	210	1906.2	257	4465.1
117	180.34	164	683.10	211	1944.6	258	4539.0
118	186.23	165	700.29	212	1983.6	259	4613.7
119	192.28	166	717.83	213	2023.2	260	4689.4
120	198.48	167	735.70	214	2063.4	261	4766.1
121	204.85	168	753.94	215	2104.2	262	4843.7
122	211.38	169	772.52	216	2145.7	263	4922.3
123	218.09	170	791.47	217	2187.8	264	5001.8
124	224.96	171	810.78	218	2230.5	265	5082.3
125	232.01	172	830.47	219	2273.8	266	5163.8
126	239.24	173	850.53	220	2317.8	267	5246.3
127	246.66	174	870.98	221	2362.5	268	5329.8
128	254.25	175	891.80	222	2407.8	269	5414.3
129	262.04	176	913.03	223	2453.8	270	5499.9

130	270.02	177	934.64	224	2500.5	271	5586.4
131	278.20	178	956.66	225	2547.9	272	5674.0
132	286.57	179	979.09	226	2595.9	273	5762.7
133	295.15	180	1001.9	227	2644.6	274	5852.4
134	303.93	181	1025.2	228	2694.1	275	5943.1
135	312.93	182	1048.9	229	2744.2	276	6035.0
136	322.14	183	1073.0	230	2795.1	277	6127.9
137	331.57	184	1097.5	231	2846.7	278	6221.9
138	341.22	185	1122.5	232	2899.0	279	6317.0
139	351.09	186	1147.9	233	2952.1	280	6413.2
140	361.19	187	1173.8	234	3005.9	281	6510.5
141	371.53	188	1200.1	235	3060.4	282	6608.9
142	382.11	189	1226.9	236	3115.7	283	6708.5
143	392.92	190	1254.2	237	3171.8	284	6809.2
144	403.98	191	1281.9	238	3228.6	285	6911.1
145	415.29	192	1310.1	239	3286.3	286	7014.1
146	426.85	193	1338.8	240	3344.7	287	7118.3
288	7223.7	310	9860.5	332	13187	354	17348
289	7330.2	311	9995.8	333	13357	355	17561
290	7438.0	312	10133	334	13528	356	17775
291	7547.0	313	10271	335	13701	357	17992
292	7657.2	314	10410	336	13876	358	18211
293	7768.6	315	10551	337	14053	359	18432
294	7881.3	316	10694	338	14232	360	18655
295	7995.2	317	10838	339	14412	361	18881
296	8110.3	318	10984	340	14594	362	19110
297	8226.8	319	11131	341	14778	363	19340
298	8344.5	320	11279	342	14964	364	19574
299	8463.5	321	11429	343	15152	365	19809
300	8583.8	322	11581	344	15342	366	20048
301	8705.4	323	11734	345	15533	367	20289
302	8828.3	324	11889	346	15727	368	20533
303	8952.6	325	12046	347	15922	369	20780
304	9078.2	326	12204	348	16120	370	21030
305	9205.1	327	12364	349	16320	371	21283
306	9333.4	328	12525	350	16521	372	21539
307	9463.1	329	12688	351	16725	373	21799
308	9594.2	330	12852	352	16931	373.98	22055
309	9726.7	331	13019	353	17138		

To determine the flow rate at the system inlet, we proceed from the following considerations.

It is known that the flow rate depends on the fluid flow rate and the cross-sectional area along which the flow moves and is determined from the known expression

$$Q = FV, \quad (4)$$

where Q is the fluid flow rate (pump capacity), m<sup>3</sup>/h; F is the cross-sectional area along which the flow moves ( $F = 0.785D^2$ ), m<sup>2</sup>; V is the fluid velocity, m/h; D is the diameter of the input section of the cavitator, m.

Moreover, given that the fluid moves in a circular section (cavitators have a cylindrical shape), the speed will be equal to

$$V = \frac{4Q}{\pi D^2} \quad (5)$$

Substituting expressions (5) and (2) in (1), and solving with respect to D, we obtain the required diameter of the inlet of the cavitator system

$$D = \sqrt{\frac{Q}{\pi} \sqrt{\frac{8 \cdot K \cdot \rho}{(P_0 - P_H)}}} \quad (6)$$

Based on the foregoing theoretical calculations, a calculation was made to determine the diameter of the cavitator for a projectile for cleaning oil and gas wells for the conditions of Ozenmunaygas JSC fields. In order to reduce the time for hoisting operations for cleaning, it is recommended to use a coiled tubing installation, and for supplying a cleaning agent, it is recommended to use a cementing unit CA - 320 (ANTs-320), with a maximum discharge pressure of 40 MPa and a maximum ideal flow rate of 26 dm<sup>3</sup> /from.

The calculation of the input diameter for the cavitation number 0.1 is 6.6 mm, and for the cavitation number 0.6 is 10.5 mm. Thus, the input diameter of the cavitator system for the conditions of the deposits of Ozenmunaygas JSC should be in the range of 6.6 to 10.5 mm.

**Conclusions.** 1. Based on the foregoing, a methodology has been proposed for determining the geometric dimensions of cavitators depending on the pressure of the pump, hydrostatic pressure of the fluid, the wells located, and the number of cavitation.

2. The input diameter of the cavitator system for the conditions of the deposits of Ozenmunaygas JSC was determined.

**А. Қ. Қасенов<sup>1</sup>, А. Х. Сыздықов<sup>1</sup>, В. И. Спирин<sup>2</sup>, М. С. Молдабеков<sup>1</sup>, М. С. Бөкенова<sup>1</sup>**

<sup>1</sup>Сәтбаев Университеті, Алматы, Қазақстан;

<sup>2</sup>«Проект центр» ЖШҚ, Тула, Ресей

#### **МҰНАЙГАЗ ҰНҒЫЛАРЫН ТАЗАЛАУҒА АРНАЛҒАН SATBAYEV UNIVERSITY ҚҰРЫЛҒЫСЫ ҮШІН КАВИТАТОРЛАРДЫ ЕСЕПТЕУ ӘДІСТЕМЕСІ**

**Аннотация.** Мақалада мұнай-газ ұнғыларын ұзақ қолдану барысында пайдалану ұнғыларының жобалық өнімділігі, ал айдау ұнғыларының қабылдауы төмендейтіні жөнінде айтылады. Жобалық өнімділік пен қабылдауын қалпына келтіру мақсатында бұл ұнғыларда біршама уақыттан кейін жөндеу-қалпына келтіру жұмыстары жүргізіледі. Ұнғылардың істен шығу себептерінің бірі – сүзгі маңы аймағының химиялық және механикалық кольматация өнімдерімен тұтасып қалуы және ұнғы түбінде механикалық тұнбалардың шөгуге болып табылады, оның нәтижесінде ұнғы өнімділігі өндіру регламентімен талап етілетін шекті мәннен азайып кетеді.

Мұнай-газ ұнғыларын тазалауға Satbayev University құрылымымен тазалау агенті ретінде кавитацияланған сұйықпен жұмыс істейтін арнайы снарядтарды қолдану ұсынылады.

Бұл снарядтар «Қазатомпром» КЕАҚ нысандарында уран рудаларын жерасты сілтілендіру мақсатында бұрғыланған геотехнологиялық ұнғыларды аяқтау кезеңінде, сондай-ақ қолданыстағы шығару және айдау ұнғыларында жөндеу-қалпына келтіру жұмыстарын (ЖҚКЖ) жүргізуде өндірістік сынақтан өткізілді.

Өндірістік сынақтар олардың жұмысқа жарамдылығын және геотехнологиялық ұнғыларды тазалау кезінде тиімділігінің жоғары екенін көрсетті.

Мұнай-газ ұнғыларының геология-техникалық шарттары геотехнологиялық ұнғылардан құрылысы бойынша, қабат қысымының мәні, ұнғы тереңдігі, қолданылатын жабдық бойынша ерекшеленетіндіктен мұнай-газ ұнғылары жағдайына арналған снаряд элементтерін есептеу қажеттілігі туындайды.

Мұнай-газ ұнғымалары жағдайында осы құрылғылардың кавитаторларын кавитация санынан, жуу сұйығының шығынынан, ұнғыдағы сұйықтың гидростатикалық қысымынан, жуу сорабының жұмыстық қысымынан тәуелді есептеу әдістемесі ұсынылған. «Өзенмұнайгаз» АҚ кен орнының ұнғылары үшін кавитаторларды есептеу мысалы берілген.

**Түйін сөздер:** ұнғының өнімділігі, қабылдауы, жөндеу-қалпына келтіру жұмыстары, кавитация, гидростатикалық қысым.

А. К. Касенов<sup>1</sup>, А. Х. Сыздыков<sup>1</sup>, В. И. Спирин<sup>2</sup>, М. С. Молдабеков<sup>1</sup>, М. С. Буkenова<sup>1</sup>

<sup>1</sup>Satbayev University, Алматы, Казахстан;

<sup>2</sup>ООО «Проект Центр», Тула, Россия

## МЕТОДИКА РАСЧЕТА КАВИТАТОРОВ ДЛЯ УСТРОЙСТВ КОНСТРУКЦИИ SATBAYEV UNIVERSITY ПО ОЧИСТКЕ НЕФТЕГАЗОВЫХ СКВАЖИН

**Аннотация.** В статье говорится, что при длительной эксплуатации нефтегазовых скважин со временем эксплуатационные скважины теряют проектную производительность, а закачные скважины – приемистость. Эти скважины через определенный промежуток времени подвергаются проведению ремонтно-восстановительных работ с целью восстановления проектного дебита и приемистости. Одной из причин выхода скважин из строя является зарастание прифилтровой зоны продуктами химической и механической кольматации и осаждением механических взвесей в отстойник скважины, в результате чего производительность скважин снижается ниже допустимых пределов, требуемых регламентом добычи.

Предлагается для чистки нефтегазовых скважин использовать специальные снаряды конструкции Satbayev University с использованием в качестве очистного агента кавитированную жидкость.

Эти снаряды прошли промышленные испытания на объектах НАО «Казатомпром» на стадии заканчивания геотехнологических скважин, пробуренных с целью подземного выщелачивания урановых руд, а также при проведении ремонтно-восстановительных работ (РВР) эксплуатируемых откачных и закачных скважин.

Промышленные испытания показали их работоспособность и высокую эффективность при чистке геотехнологических скважин.

В связи с тем, что геолого-технические условия нефтегазовых скважин отличаются от геотехнологических скважин по их конструкции, величин пластового давления, глубин скважин, применяемого оборудования появляется необходимость проведения расчетов элементов снаряда с целью получения кавитированной жидкости для условий нефтегазовых скважин.

Предложена методика расчета кавитаторов этих устройств для условий нефтегазовых скважин в зависимости от числа кавитации, расхода промывочной жидкости, гидростатического давления жидкости находящегося в скважине, рабочего давления промывочного насоса. Приведен пример расчета кавитаторов для скважин месторождений АО «Озенмунайгаз».

**Ключевые слова:** производительность скважины, приемистость, ремонтно-восстановительные работы, кавитация, гидростатическое давление.

### Information about authors:

Kassenov Almabek Kasenovich, Professor Satbayev University, candidate of technical sciences; kassenov07@inbox.ru; <https://orcid.org/0000-0002-3004-5598>

Syzdykov Askar Hamzaevich, Professor Satbayev University, candidate technical of science (Senior Researcher), Dr. PhD; syzdykov\_su@mail.ru; <https://orcid.org/0000-0002-0182-4330>

Spirin Vasily Ivanovich, doctor of technical sciences, Corresponding Member of the Russian Academy of Natural Sciences; vispirin@bk.ru; <https://orcid.org/0000-0001-7216-5515>

Moldabekov Murat Smanovich, assistant professor of Satbayev University, Dr. PhD; moldabekov\_ms@mail.ru; <https://orcid.org/0000-0002-1623-0324>

Bukenova Mereke Sailaubekovna, lecturer of the department "Petroleum Engineering", Satbayev University, master of oil and gas business; bukenova77@mail.ru; <https://orcid.org/0000-0002-2224-6453>

### REFERENCES

[1] Kassenov A., Pernesh E.K., Batiev R.A., etc. Device for cleaning of filter column and bottom deposits of wells of various purposes. The identity of the author № 108375.

[2] Kassenov A., Ratov B., Moldabekov M., Faizulin A., Bukenova M. The reasons of formation of oil seals when drilling geotechnological wells for underground leaching of uranium ores. 16th International Multidisciplinary Scientific GeoConference SGEM 2016, [www.sgem.org](http://www.sgem.org), SGEM2016 Conference Proceedings, Albena, Bulgaria, ISBN 978-619-7105-55-1 / ISSN 1314-2704, June 28 - July 6, 2016, Book 1. Vol. 1. P. 633-640. DOI: 10.5593/SGEM2016/B11/S01.080.

[3] Kassenov A.K., Spirin V.I., Moldabekov M.S., Faizulin A.Z., Baibussinova Z.B. The analysis of modern technology and technique applied in the completion of geotechnological wells and remedial works in them. News of the national academy of sciences of the republic of Kazakhstan, series of geology and technical sciences, ISSN 2224-5278, Vol. 3, N 429 (2018), 283–289.

[4] Kassenov A.K., Moldabekov M.S., Budyukov Y.E., Spirin V.I. Development of devices for decolmation of geotechnical well filters and preliminary tests in production conditions. Scientific, technical and production Mining Journal of Kazakhstan. Almaty, 2018. N 8. P. 40-42.

[5] Serdyuk N.I. Cavitation methods of decolmatration of filter area of drilling wells. – M.: JSC «VNIOENG», 2004. 176 p.

[6] Kasenov A.K. Technology and technique of drilling wells for solid minerals. Manual. KazNTU of K.I. Satpayev. 2003. 86 p.

[7] Biletskiy M.T. Calculation of flow rate and pressure of flushing fluid in the well using a computer. Methodical management. Alma-Ata: KazPTI. 1988. 31 p.

[8] Volkov A.I., Zharskiy I.M. Grand Chemical Directory - Mn.: Modern School, 2005. 608 p.

**NEWS**

OF THE NATIONAL ACADEMY OF SCIENCES OF THE REPUBLIC OF KAZAKHSTAN

**SERIES OF GEOLOGY AND TECHNICAL SCIENCES**

ISSN 2224-5278

Volume 2, Number 440 (2020), 87 – 95

<https://doi.org/10.32014/2020.2518-170X.35>

**B. Kenzhaliyev<sup>1</sup>, D. M. Yesimova<sup>1</sup>, T. Y. Surkova<sup>1</sup>,  
A. Soemowidagdo<sup>2</sup>, L. U. Amanzholova<sup>1</sup>, N. B. Egorov<sup>3</sup>**

<sup>1</sup>Satbayev University, Institute of Metallurgy and Ore Benefication, Almaty, Kazakhstan;

<sup>2</sup>Yogyakarta State University, Indonesia;

<sup>3</sup>Tomsk Polytechnic University Tomsk, Russia.

E-mail: bagdaulet\_k@satbayev.university;

d.yessimova@satbayev.university; arianto\_ls@uny.ac.id;

## **TRANSFORMATION OF THE RARE EARTH ELEMENTS AND IMPURITY ELEMENTS COMBINATIONS IN THE COURSE OF pH PREGNANT SOLUTION MODIFICATION**

**Abstract.** Currently, the scientific and engineering progress is mainly associated with the rare earth elements application. A lot of spheres of effective REEs use are numbered as in military so the civil industries. Additional raw materials sources of the REEs concentration and probable extraction are explored due to the increased demand in the last two decades. The man-made mineral formations (MMF) after phosphate ores processing is one of them. The REEs' content reaches 5.0%. The MMF processing technology consists of the following stages: a feedstock development; pregnant solutions treatment from impurities; and the REEs concentrate extraction. A loss of 30% of REEs at the second stage is the main failure, which is due to their co-precipitation with the impurity elements at pH pregnant solution adjustment. To find means and methods of making the REEs co-precipitation lower the solutions and residues generated in the course of pH standardized test solutions modification set based on the REEs and impurity elements content in the pregnant solutions have been studied by the physical and chemical methods. As part of studies, the pH initial solutions were improved within the values range of 1.7-4.0 pH by sodium hydroxide and ammonia. According to a counteracting solution, the various ways of combinations transformation of the REEs and impurity elements are provided. Appropriate conditions of pregnant solutions treatment are determined at driving to the least of the REEs co-precipitation based on the results.

**Key words:** rare earth elements, man-made mineral formations (MMF), pH solution, physical and chemical researches.

**Introduction.** Increasing demand for the REEs is explained by its application in various spheres. The rare grounds are the major asset to the production of the material for the high technology spheres of consumption, such as electron and electro-optic branches, information technology, biomedicine, environment protection, energy-saving [1-3].

Increased demand for the REEs in the last two decades forces them to find out the new raw sources containing the REEs and to improve the methods of their extraction [4-11]. Among these are the man-made mineral formations after the phosphate uranium ores processing the REEs concentrate is acquired from in SARECO LLP – an affiliate of Kazatomprom NAC [12-14].

**Research procedure.** The standardized test solutions of the following composition were used as the feedstock, g/dm<sup>3</sup>: Fe-5.5; P - 7.2; La -2.1 and Fe-5.5; P - 7.2; CE -2.1. pH value of the solutions equaled 0.6.

The REEs sulphates of chemically pure qualification, state standard 6-09-4676-83 and sodium orthophosphate reagent grade qualification, state standard 245-76 were used to prepare the standardized test solution. Considering the feedstock contains Fe in various modifications we have synthesized and identified oxide ferrum hydroxide and the standardized test solution of the above composition has been prepared based on it.

X-ray phase analysis identified the synthesized substance as a mixture of Fe<sub>2</sub>O<sub>3</sub> • H<sub>2</sub>O and Fe<sub>3</sub>O<sub>4</sub> • H<sub>2</sub>O.

Sodium hydroxide of the reagent grade qualification, state standard 4328-77, 25% of ammonia, of reagent grade qualification, state standard 3760-79 were used as the reagents to counteract the standardized test solution. Sulfuric acid was used as well of chemically pure qualification in this study, state standard 4204-77.

The standardized test solution adjustment to the determined pH values was carried out with sodium hydroxide and ammonia. The adjusted solution at a certain pH, after 0.5 hours, was filtered; the filtrate and the precipitate were analyzed to have components by physical and chemical methods.

**Methods of analysis.** The REEs quantitative content was determined using an atomic emission spectrometer with an inductively coupled plasma Optima 8300DV, and phosphorus and iron according to the generally accepted methods [15]. The solutions spectra were obtained by Infrared Fourier spectrometer "ALPHA" in the spectral range of 4000–400  $\text{cm}^{-1}$  PLATINUMATR module. The precipitation spectra of the 1st and the 2nd series of the experiments were obtained using Infrared Fourier spectrometer ALPHA, ALPHA-T module (pellets with KBr) and Avatar 370 (Nujol Mull) in the 4000-400 $\text{cm}^{-1}$  spectral range.

The X-ray phase analysis method data were obtained using a D8 ADVANCE (Bruker) Set of Cu Ka radiation, a tube voltage of 40 kV, a current of 40 mA. The processing of the obtained diffractogram data and the calculation of the interplanar distances were carried out using the EVA software. The Search/match program with the powder diffractometric database of PDF-2 was used to sample decoding and phase search.

**The results of researches.** The REEs content within the man-made mineral formations used by SARECO LLP to obtain a concentrate exceeds 5.0% and may well compete with the mineral. The light group elements are predominate. The main impurities are iron, phosphorus, magnesium, calcium, aluminum in a smaller amount.

The technology of Man-made Mineral Formations (MMF) processing with obtaining the REEs concentrate includes the following processing stages: raw materials development; pregnant solutions treatment from impurities; obtaining the REEs concentrate.

The REEs lost is mostly remarkable at the second stage - pregnant solutions treatment from impurities. This stage involves the ferric iron and phosphorus precipitation, the most representative impurity elements, as well as, to a lesser extent, aluminum, calcium and magnesium. Up to 30% of the REEs are co-precipitated together with the above elements, which are subsequently difficult to separate from impurities and isolate from the sediment. In this regard, the REEs co-precipitation reducing issue during the pregnant solutions treatment from impurities is challenging for production.

In order to find a method of the REEs co-precipitation reducing of the rare-earth elements with impurities, their performance in the process of pH change of the pregnant solution is necessary to be studied.

After examining the statistical data of the individual elements content in the pregnant solutions over the year, we have prepared the standardized test solutions that, by the main components (iron, phosphorus, REEs total), duplicate the original pregnant from sulfuric acid leaching of MMF. The lanthanum concentration in the first solution and cerium in the second was equal to the REEs total. These elements were chosen to take into account the REEs composition in the pregnant solution, where the light group prevails.

Considering that the main components of the pregnant and standardized test solutions are iron, phosphorus and the REEs, the iron orthophosphates and the REEs can be assumed to be produced while adjusting the pH values. The literature references speak of pH orthophosphates formation of the individual REEs varies widely. Thus, the pH formation of praseodymium orthophosphate –  $\text{PrPO}_4 \cdot n\text{H}_2\text{O}$  – is 1.5, the samarium orthophosphate –  $\text{SmPO}_4 \cdot n\text{H}_2\text{O}$  – 1.7; gadolinium orthophosphates –  $\text{GdPO}_4 \cdot n\text{H}_2\text{O}$  and ytterbium -  $\text{YbPO}_4 \cdot n\text{H}_2\text{O}$ . At the same time, the iron phosphates formation is observed at pH 1.5-1.7 [16-18]. Based on the literature data, we have chosen the alteration range of pH solution varying from 1.7-4.0.

As part of the study, the initial standardized test solutions were successively counteracted to pH values of 1.7; 2.5; 3.2; 4.0 by sodium hydroxide in the first set of experiments and ammonia in the second. As mentioned above, the improved solution was filtered, the filtrate and sediment were analyzed for the content of the component by chemical method, and the states of their availability were analyzed by IR spectroscopic and X-ray diffraction methods. The results of chemical analysis of the initial solutions and after improving the pH values by sodium hydroxide are provided in table 1.

Table 1 – Precipitation rate of rare earth and impurity elements by the sodium hydroxide depending on pH solution

pH solution	A precipitation rate,%			A precipitation rate,%		
	Fe	P	La	Fe	P	Ce
1.7	89.0	44.7	25.0	90.0	40.7	22.8
2.5	91.9	48.3	79.8	93.9	47.3	80.9
3.2	95.2	49.9	85.7	94.1	50.9	91.7
4.0	99.0	51.1	98.1	98.9	58.1	95.0

As of the table as far as the pH values of standardized test solutions increase from 1.7 to 4.0, the iron sedimentation rate increases to almost 98–99%, phosphorus increases to 45–50%, the rare earth's sediment intensively in the 1.7-3.2 pH range, then the sedimentation process slows down. At a pH value of 1.7, the degree of co-precipitation of the REEs is 25–26%, and at 2.5 is over 80%.

IR spectroscopic studies of the initial lanthanum-containing solution and adjusted at different pH values have testified that in the spectrum of the initial solution (a) there are absorption bands of  $\nu(\text{OH}) - 3359 \text{ cm}^{-1}$  valences, bending  $\delta\text{HOH}-1632 \text{ cm}^{-1}$  fluctuations of molecular water. The ion hydrosulfate –  $\text{HSO}_4^-$ , coordinated by the metal — 1175, 1045, 880, 579  $\text{cm}^{-1}$  [19].

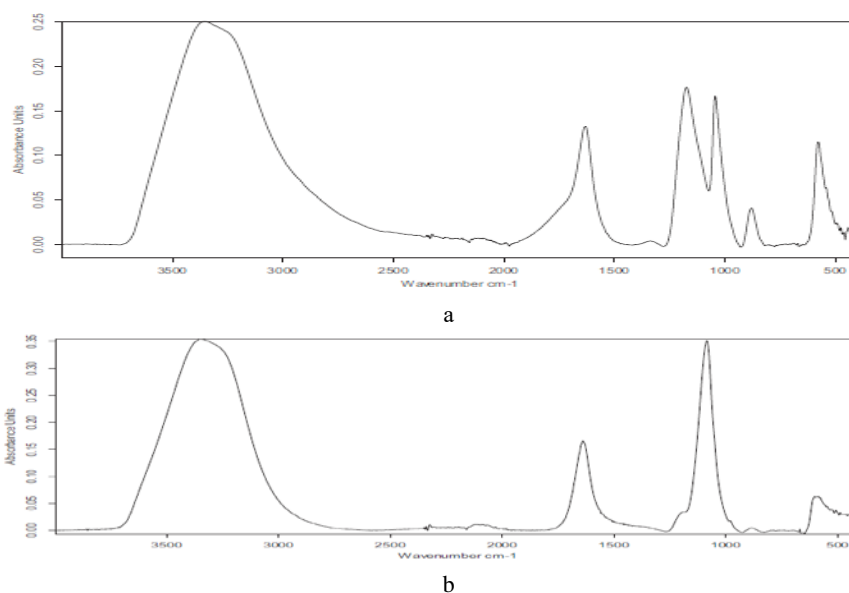

Figure 1 – IR spectra of the initial standardized test solution (a) and adjusted at 1.7 pH (b)

The solution spectrum obtained at 1.7 pH differs from the previous one. The spectrum shows absorption bands of  $\nu(\text{OH}) - 3354 \text{ cm}^{-1}$  valence, and bending  $\delta\text{HOH}-1640 \text{ cm}^{-1}$  fluctuations of the molecular water [20].

An ion sulfate -  $[\text{SO}_4]^{2-} - 1085, 981, 604 \text{ cm}^{-1}$  [18, 19] prevails over an ion hydrosulfate -  $\text{HSO}_4^- - 1189, 887, 587 \text{ cm}^{-1}$  [18]. Phosphate absorption band appears: a  $[\text{PO}_4]^{3-}$  group -  $1085 \text{ cm}^{-1}$  [21].

The spectra of improved at pH 2.5; 3.2; 4.0 solutions should be noted to have a similar profile, a shift of the  $\nu_3 [\text{SO}_4]^{2-}$  band to the long-wavelength region is observed with increasing content of  $[\text{PO}_4]^{3-}$  ions, which indicates a change in the concentration of the component. The  $\nu[\text{OH}]^-$  and  $\nu_3 [\text{SO}_4]^{2-}$  band intensity redistribution give evidence of the salt background change of the solution.

IR spectroscopic studies of precipitations obtained in the process of pH changing of the initial standardized test lanthanum-containing solution are provided in figure 2 and table 2.

An analysis of the studies performed the sediment spectrum obtained at pH standardized test lanthanum-containing solution adjusting to pH = 1.7 one fluctuation band  $\nu_3 (\text{F}_2)$  and two bands  $\nu_4 (\text{F}_2)$  of the tetrahedral ion  $[\text{SO}_4]^{2-}$  describing the sulfate symmetry phase ion D<sub>2</sub>, which corresponds to  $\text{Na}_2\text{SO}_4$  thenardite is traced. As the pH of the initial solution changes from 1.7 to 4.0, the intensity of the

fluctuation band  $\nu_3$  (F2) increases and at 3.2 and 4.0 pH it splits into two (figure 2), its intensity increases 3 times (table 2), respectively another sulfate phase dominates.

An increase of the  $\nu_3$  band intensity may indicate both an increase in the sulfate content and the formation of a new sulfate phase, for example, REE double sulfates. If a phase can be stated as an impurity at 1.7 and 1.8pH, then at 3.2 and 4.0pH is as an established independent phase.

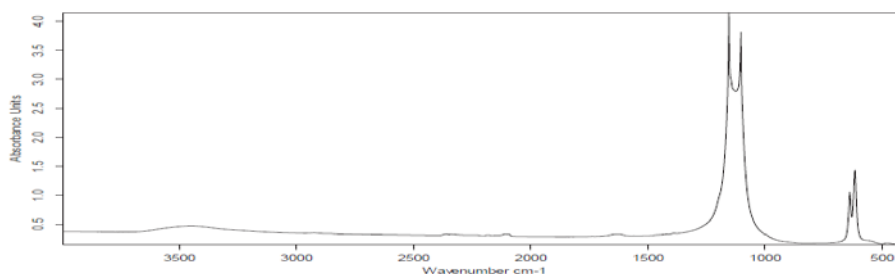

Figure 2 – IR spectra of a sediment obtained at 4.0 pH precipitation by sodium hydroxide

Table 2 – Bands intensity values of the IR spectra of sediments obtained by pH standardized test solution adjustment

pH value	Fluctuation frequencies $\nu_3$	Relative intensity	Fluctuation frequencies $\nu_4$	Relative intensity
10-10 1.7	1128.67	1.194	638.24	0.107
			616.94	0.560
13-13 1.8	1128.55	1.391	637.96	0.127
			616.71	0.623
14-14 2.5	1129.97	1.555	638.21	0.143
			617.04	0.669
15-15 3.2	1148.40	3.852	638.36	0.425
	1106.35	0.933	616.98	1.210
16-16 4.0	1154.78	3.936	638.41	0.464
	1104.06	1.118	616.94	1.289

The double salt availability is confirmed by the X-ray phase analysis according to which the main components of the lanthanum-containing sediment are the double salt of  $\text{NaLa}(\text{SO}_4)_2$  and sodium sulphate - Thenardite -  $\text{Na}_2\text{SO}_4$ .

X-ray diffraction data maintain that the iron in the sediment is Iron Oxide Sulphate Hydrate -  $\text{Fe}_{14}\text{O}_3(\text{SO}_4)_{18} \cdot \text{H}_2\text{O}$ ; Iron Phosphate -  $\text{FePO}_4$  and Iron Oxide -  $\text{Fe}_2\text{O}_3$ , i.e. in the process of pH solution adjustment, iron is partially transformed into ferric iron phosphate and sulfate of a complex composition.

The study of cerium-containing solutions with comparable concentrations of components and pH values has demonstrated the similar results.

Thus, the data obtained speak of that in the course of pH initial solution ( $\text{pH} = 0.6$ ) process adjustment the hydrosulfates are transformed into sulfates with the subsequent formation of double sulfates of the rare-earth elements, phosphates from hydro and dihydrogen phosphates into orthophosphates, with the formation of iron orthophosphate. The iron is present also in the form of sulfate of complex composition.

At the second stage of the research, the initial lanthanum and cerium containing solutions were adjusted with ammonia.

Changes in the composition of the precipitate obtained in the process of adjusting the initial solution with ammonia are most clearly seen in the example of cerium-containing solutions.

Figure 3 shows the precipitation spectra obtained in the process of improving the pH of the initial cerium-containing standardized test solution.

It follows from the figure that an increase in the intensity of the absorption bands is observed in the ranges of sulfate ion and phosphate ion fluctuations with increasing pH values in the range of 1.7–4.0. In view of overlapping the absorption areas of the sulfate ion and the phosphate ion, an increase in the total

content of the compounds that comprise these groups is possible to observe. A redistribution of the intensities of the bands was observed at wavenumbers of 1148, 1107, 1063, 615, 596, 574  $\text{cm}^{-1}$ , which is due to the ratio variation of the salts present in the samples. In the long-wavelength area of all spectra, a peak at 596  $\text{cm}^{-1}$  was recorded corresponding to the  $\text{NaCe}(\text{SO}_4)_2 \cdot (\text{H}_2\text{O})$  compound. In the spectra of the samples obtained during precipitation, in the pH range of 2.2-4.0, a peak is observed at a wavenumber of 615  $\text{cm}^{-1}$ , which falls within the range of fluctuation of  $\nu_4$  sulfate-ion in sodium sulfate, ammonium sulfate and  $\nu_4$  phosphate-ion fluctuation is in the  $\text{CePO}_4$  compound [19–23].

According to X-ray phase analysis, in all samples of cerium-containing sediments a double salt of  $\text{NaCe}(\text{SO}_4)_2 \cdot (\text{H}_2\text{O})$  compound, cerium orthophosphate  $\text{CeO}_4$ , and iron in the form of  $\text{FeO}(\text{OH})$  compound are available.

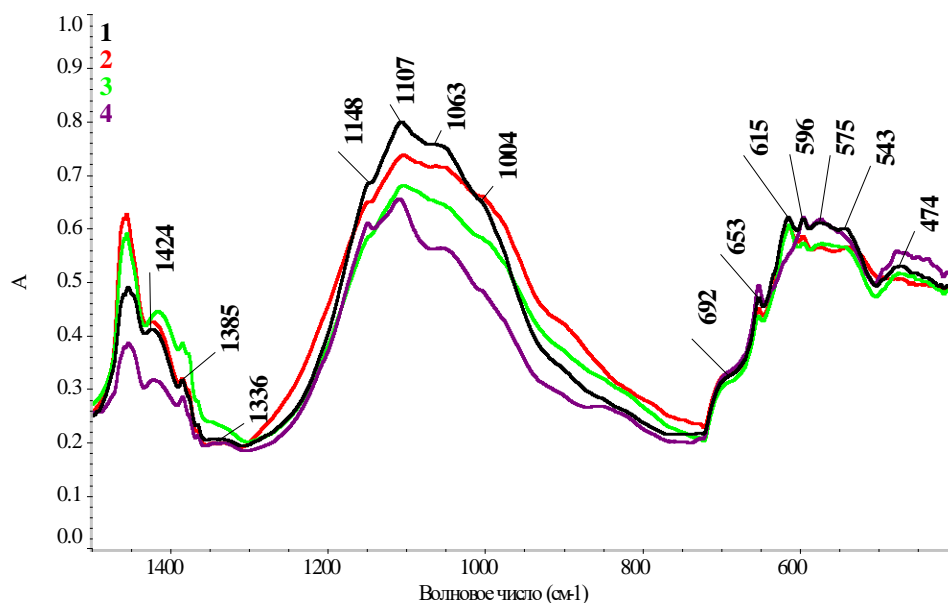

Figure 3 – IR precipitate spectrum obtained at 1.7 pH by ammonia precipitation of 1-4 pH values, respectively: 1.7; 2.2; 3.2; 4.0

By the ammonia precipitation the double salt is may be assumed to be formed due to sodium ions of a standartized test solution introduced in the form of sodium orthophosphate and its amount is limited by the sodium concentration in the solution. Double salt of lanthanum or cerium with ammonia under these conditions is not formed. Excess REEs is mixed with phosphorus into the REEs orthophosphate.

Thus, according to the researches and the results, the transformation of the compound of the rare-earth elements can be assumed to proceed not in the same manner when pH values are adjusted by sodium hydroxide and ammonia. Provided that in the first case, the formation of double salts prevails, in the second is REEs orthophosphate.

At the same time, the literary sources [17] reveal the solubility of the double salts of rare-earth elements increases with a decrease in the temperature of their precipitation. In this regard, we carried out the precipitation of the impurity elements from the pregnant solution at 1.7 pH by sodium hydroxide under standard conditions and during cooling. The results are provided in table 3 and in figure 4.

Table 3 – Source data of the REEs content in the pregnant solution

pH	Content mg / l							
	La	Ce	Dy	Er	Eu	Gd	Ho	Lu
0,6	102	103	58.0	27.0	3.9	65.0	13.1	5.1
	Nd	Pr	Sm	Tb	Tm	Y	Yb	
	132	41.3	34.0	9.9	4.7	43.6	26.6	

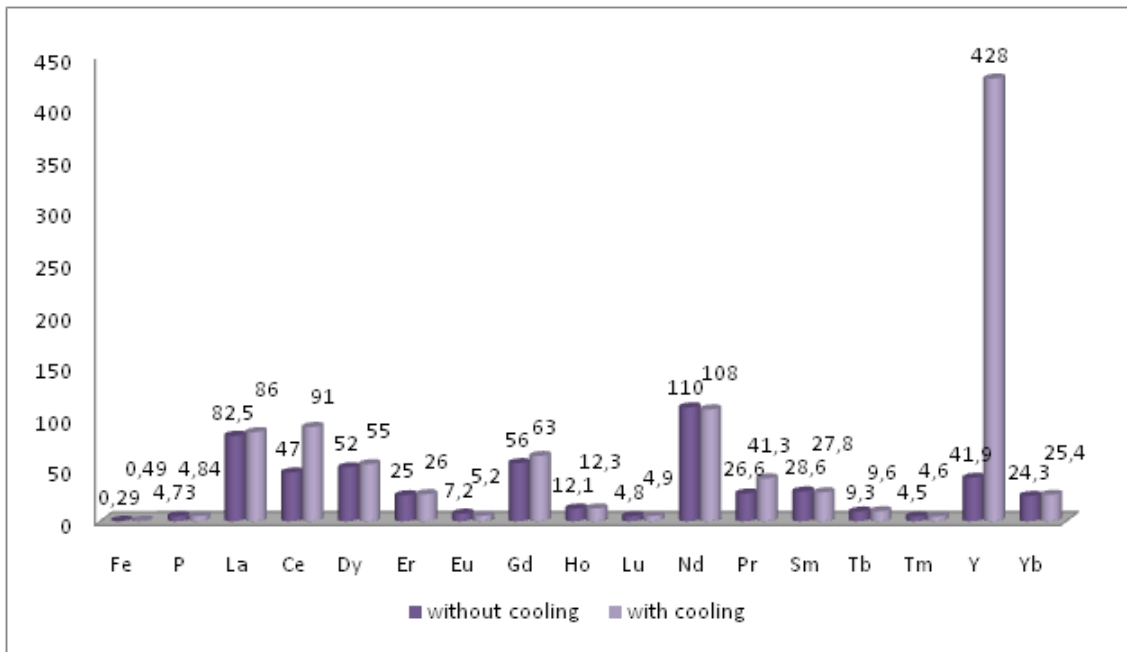

Figure 4 – Individual REEs precipitation, depending on the conditions

The given results make it clear the solution is under cooling within the precipitation of impurity elements process, leads to the solubility of the rare-earth elements sulfates increase, and their co-precipitation with sediment decreases. The data provided demonstrate the content of all rare-earth elements in the solution in the process of pH solution values improvement under the cooling conditions is higher than under standard conditions, but to the different extent. This is especially evident as concerns cerium and yttrium and, to a lesser extent, lanthanum, dysprosium, gadolinium and praseodymium. This effect is not observed when improving the pH solution values with ammonia.

Thus, using this technique in production to achieve the desired results, the precipitation is preferably carried out with sodium hydroxide, or in the 2 stages with sodium hydroxide to 1.0 pH and then ammonia to 1.7 pH.

**Conclusion.** The development and improvement of technology in the metallurgy for the production of rare and rare earth metals for different industries has been carried out by Kazakhstani scientists [24-28]. These studies of standardized test solutions were conducted to resolve co-precipitation issue of the REEs, which compound is mainly duplicate the initial pregnant MMF after sulfuric acid leaching. The improvement of pH standardized test solutions was in the range of 1.7-4.0 by sodium hydroxide and ammonia.

The sediment and filtrate after the standardized test solutions adjustment were analyzed to have components content by chemical method and the states of their availability were analyzed by IR spectroscopic and X-ray diffraction methods. Irregular combinations were observed in the process of pH improvement by various counteracting reagent as the results provided. Double salts prevail affected by sodium hydroxide, and ammonia is the REEs orthophosphate is prevailed.

Considering the double sulphates of the REEs possess abnormal properties, their solubility increases when the solution temperature decrease (Figure 4) – the impurity elements precipitation when cooling in production will result in the REEs co-precipitation decrease. To reach the result precipitation is preferable by sodium hydroxide or in the second stage by sodium hydroxide to 1.0 pH value and further by ammonia to 1.7 pH value.

Б. Кенжалиев<sup>1</sup>, Д. М. Есимова<sup>1</sup>, Т. Ю. Суркова<sup>1</sup>,  
А. Сумовидагдо<sup>2</sup>, Л. У. Аманжолова<sup>1</sup>, Н. Б. Егоров<sup>3</sup>

<sup>1</sup>Satbayev University, Металлургия және кен байыту институты, Алматы, Қазақстан;

<sup>2</sup>Джокьякарта мемлекеттік университеті, Индонезия;

<sup>3</sup>Томск политехникалық университеті, Томск, Ресей

### ҮРДІСТЕ ӨНІМДІ ЕРІТІНДІДЕГІ рН ӨЗГЕРУІНЕ ҚАРАЙ, СИРЕК КЕЗДЕСЕТІН ЖӘНЕ КІРМЕ ЭЛЕМЕНТТЕР ҚОСЫЛЫСТАРЫНЫҢ ӨЗГЕРТІЛУІ

**Аннотация.** Сирекжер элементтеріне (СЖЭ) жоғары сұраныс оның түрлі салада пайдаланылуымен байланысты. СЖЭ қолданыстың жоғарытехнологиялық - электрондық және электрооптикалық, ақпараттық технологиялар, биомедицина, қоршаған ортаны қорғау, энергияны үнемдеу сияқты салаларына арналған материалдар өндірісінде негізгі актив болып табылады.

Соңғы жиырма жылдың ішінде СЖЭ деген сұраныстың артуына байланысты, оларды концентрлеу және мүмкіндігінше бөліп алу үшін қосымша шикізаттар іздестіріліп келеді, оларды бөліп алу әдістері жетілдірілуде. Осылардың біріне, фосфатты уран кендерін қайта өңдегенде пайда болатын техногенді минералды түзілімдер (ТМТ) жатады, олар «SARECO» ЖШС – «Қазатомпром» ҰАК филиалында алынады. Ондағы СЖЭ-ің үлесі 5,0 %-ды құрайды және минералмен толықтай бәсекелесе алады. Құрамында жеңіл элементтердің топтары басым. Негізгі қоспалары болып темір, фосфор, магний, кальций және аз мөлшерде алюминий табылады. ТМТ технологиясын қайтадан өңдеу, келесідей: бастапқы шикізатты ашу; өнімді ерітінділерді қоспалардан тазалау; СЖЭ концентрациясын алу сияқты бөлімдерінен тұрады. Бұл технологияның негізгі кемшіліктерінің бірі, екінші сатыда, демек өнімді ерітіндінің рН реттеу кезінде қоспа элементтерімен қоса олардың бірге шөгілуіне байланысты шамамен 30 % СЖЭ жоғалады.

СЖЭ-нің бірге шөгілуінің төмендету тәсілдері мен олардың жолдарын іздеу үшін, өнімді ерітінділердегі сирекжер және қоспа элементтердің үлестік көрсеткіштерімен, әрі модельді ерітіндідегі үрдістер рН өзгеруінен қалыптасқан шөгінділер мен ерітінділердің құрамы, физикалық-химиялық әдістермен зерттелінді.

Зерттеу барысында, бастапқы ерітінділердің рН деңгейі 1,7 – 4,0 аралығындағы, аммиак және натрий гидрототығымен реттелінді. Бейтараптау–ерітіндісімен сирекжер және қоспа элементтер қосылыстарының өзгертулеріндегі әртүрлі жолдары көрсетілді. Алынған зерттеу нәтижелерімен, СЖЭ анағұрлым төмен бірге шөгілдіргендегі өнімді ерітінділерді тазалаудың оңтайлы жағдайы анықталды.

Келтірілген қорытындылардан ерітіндіні тұнбалау кезінде суыту СЖЭ сульфаттарының ерігіштігін арттыруға және олардың тұнбамен бірге шөгуін төмендетуге әкелетінін түсінуге болады. Алынған мәліметтер рН мәнін жақсарту кезінде ерітіндіде барлық СЖЭ болуының стандартты шарттарға қарағанда суыту кезінде түрлі дәрежеде жоғары екенін көрсетеді. Бұл, әсіресе, церий мен иттрийге, және аз мөлшерде лантан, диспрозий, гадолиний және празеодимге қатысты анық. Бұл көрініс амиагы бар ерітіндінің рН мәнін жақсарту кезінде байқалмайды.

Осылайша, бұл технологияны қажетті нәтижеге жету үшін өндірісте қолданғанда, тұндыруды натрий гидрототығымен немесе 2-ші кезеңде натрий гидрототығымен 1,0 рН-қа дейін, ал кейін аммиакпен 1,7 рН-қа жүргізу қажет.

**Түйін сөздер:** сиреккездесетін элементтері, техногенді минералды түзілімдер (ТМТ), рН ерітіндісі, физикалық-химиялық зерттеу.

Б. Кенжалиев<sup>1</sup>, Д. М. Есимова<sup>1</sup>, Т. Ю. Суркова<sup>1</sup>,  
А. Сумовидагдо<sup>2</sup>, Л. У. Аманжолова<sup>1</sup>, Н. Б. Егоров<sup>3</sup>

<sup>1</sup>Satbayev University, Институт металлургии и обогащения, Алматы, Казахстан;

<sup>2</sup>Джокьякартский государственный университет, Индонезия;

<sup>3</sup>Томский политехнический университет, Томск, Россия

### ТРАНСФОРМАЦИЯ СОЕДИНЕНИЙ РЕДКОЗЕМЕЛЬНЫХ И ПРИМЕСНЫХ ЭЛЕМЕНТОВ В ПРОЦЕССЕ ИЗМЕНЕНИЯ рН ПРОДУКТИВНОГО РАСТВОРА

**Аннотация.** Растущий спрос на редкоземельные элементы (РЗЭ) объясняется его применением в различных сферах. РЗЭ являются основным активом в производстве материалов для высокотехнологичных сфер потребления, таких как электронная и электрооптическая отрасли, информационные технологии, биомедицина, защита окружающей среды, энергосбережение.

В связи с возросшим в последние два десятилетия спросом на РЗЭ, изыскиваются дополнительные сырьевые источники их концентрирования и возможного извлечения, совершенствуются методы их получения. Одним из них являются техногенные минеральные образования (ТМО) от переработки фосфатных урановых руд, которые приобретаются в ТОО «SARECO» – филиал НАК «Казатомпром». Содержание в них РЗЭ достигает 5,0 % и вполне может конкурировать с минералом. Группа легких элементов преобладают. Основными примесями являются железо, фосфор, магний, кальций, алюминий в меньшем количестве. Технология переработки ТМО включает следующие переделы: вскрытие исходного сырья; очистка продуктивных растворов от примесей; получение концентрата редкоземельных элементов. Одним из основных недостатков данной технологии является потеря почти 30% РЗЭ на второй стадии, в связи с соосаждением их с примесными элементами при корректировке pH продуктивного раствора.

Для поиска путей и способов снижения соосаждения РЗЭ были изучены физико-химическими методами составы растворов и осадков, образующихся в процессе изменения pH модельных растворов, сформированных на основе данных о содержании редкоземельных и примесных элементов в продуктивных. В ходе исследований pH исходных растворов корректировали в диапазоне значений pH 1.7-4.0 гидроксидом натрия и аммиаком. Показаны разные пути трансформации соединений редкоземельных и примесных элементов в зависимости от раствора-нейтрализатора. На основании полученных результатов определены оптимальные условия очистки продуктивных растворов при минимизировании соосаждения РЗЭ.

Приведенные результаты дают понять, что раствор при охлаждении в процессе осаждения примесных элементов приводит к увеличению растворимости сульфатов РЗЭ и уменьшению их соосаждения с осадком. Представленные данные демонстрируют содержание всех РЗЭ в растворе в процессе улучшения значений pH раствора в условиях охлаждения выше, чем в стандартных условиях, но в разной степени. Это особенно очевидно в отношении церия и иттрия и, в меньшей степени, лантана, диспрозия, гадолиния и празеодима. Этот эффект не наблюдается при улучшении значений pH раствора с аммиаком.

Таким образом, используя эту технологию в производстве для достижения желаемых результатов, осаждение предпочтительно проводят гидроксидом натрия или на 2-й стадии гидроксидом натрия до 1,0 pH, а затем аммиаком до 1,7 pH.

**Ключевые слова:** редкоземельные элементы, техногенные минеральные образования (ТМО), pH раствора, физико-химические исследования.

#### Information about the authors:

Kenzhaliyev Bagdaulet, Doc.of Eng., Professor, Vice-Rector for Research, Satbayev University; General Director – Chairman of the Board, Institute of Metallurgy and Ore Benefication, Almaty, Kazakhstan; bagdaulet\_k@satbayev.university; <https://orcid.org/0000-0003-1474-8354>

Yesimova Dinara Muratbekovna, Master of Eng. in Metallurgy, Engineer, Satbayev University, Institute of Metallurgy and Ore Benefication, Almaty, Kazakhstan; [d.yessimova@satbayev.university](mailto:d.yessimova@satbayev.university); <https://orcid.org/0000-0002-1582-6732>

Surkova Tat'yana Yur'evna, Candidate of Eng., Senior Researcher, Satbayev University, Institute of Metallurgy and Ore Benefication, Almaty, Kazakhstan; [t.surkova@satbayev.university](mailto:t.surkova@satbayev.university); <https://orcid.org/0000-0001-8271-125X>

Soemowidagdo Arianto, PhD, Yogyakarta State University, Indonesia; [arianto\\_ls@uny.ac.id](mailto:arianto_ls@uny.ac.id); <https://orcid.org/0000-0001-7489-8050>

Amanzholova Leila Uralovna, Candidate of Eng., Senior Researcher, Satbayev University, Institute of Metallurgy and Ore Benefication, Almaty, Kazakhstan; [l.amanzholova@satbayev.university](mailto:l.amanzholova@satbayev.university); <https://orcid.org/0000-0002-9582-3522>

Egorov Nikolay Borisovich, Candidate of Chemistry, Associate Professor, Division for Nuclear-Fuel Cycle School of Nuclear Science and Engineering, Tomsk Polytechnic University, Tomsk, Russia; [egorov@tpu.ru](mailto:egorov@tpu.ru); <https://orcid.org/0000-0002-3875-9798>

#### REFERENCES

- [1] Naumov A.V. (2008) Review of the world market of rare-earth metals // News of universities. Non-ferrous metallurgy [Obzor mirovogo rynka redkozemel'nyh metallov Izvestija vuzov. Cvetnaja metallurgija] 1: 22-31. ISSN: 0021-3438
- [2] Mihajlov V.A. (2010) Rare Earth Ores [Redkozemel'nye rudy mira] Kiev. ISBN:978-3-540- 70777-6
- [3] Gorshkov K.V.A., et al., (2017). Heat-sensitive pick-up cable for fire alarm systems in aircraft, chemical reactors, industrial enterprises. Patent RF, no RU2605548-C1.
- [4] Bochevskaja E.G., Abisheva Z.S., Karshigina Z.B., Turdalieva B.D., Kvjatkovskaja M.N. (2016) The behavior of rare earth elements during nitric acid leaching of slag from phosphorus production // Complex use of mineral resources [Povedenie redkozemel'nyh jelementov pri azotnokislom vyshhelachivanii shlaka fosfornogo proizvodstva Kompleksnoe ispol'zovanie mineral'nogo syr'ja] 1: 9-16. [www.kims-imio.kz](http://www.kims-imio.kz)
- [5] Seryh V.I., Kopobaeva A.N. (2019) Patterns of placement of rare-metal deposits of Central Kazakhstan // News of the National Academy of Sciences of the Republic of Kazakhstan. Series of geology and technical sciences [Zakonomernosti

razmeshhenija redkometall'nyh mestorozhdenij Central'nogo Kazahstana // Izvestija nacional'noj akademii nauk respubliki kazahstan. Serija geologii i tehniceskikh nauk]. 2019. Vol. 1, N 433. P. 143-150 (in Russ.). ISSN 2224-5278. <https://doi.org/10.32014/2019.2518-170X.18>

[6] Shokobaev N.M., Zhurinov M.Zh., Zhumabaeva D.S., Ivanov N.S., Abil'magzhanov A.Z. (2018) Development of a sorption technology for the extraction of rare-earth metals from solutions of underground downhole leaching of uranium. News of the National Academy of Sciences of the Republic of Kazakhstan. Series of geology and technical sciences [Razrabotka sorbcionnoj tehnologii izvlechenija redkozemel'nyh metallov iz rastvorov podzemnogo skvazhinnogo vyshhelachivaniya urana // Izvestija nacional'noj akademii nauk respubliki kazahstan. Serija geologii i tehniceskikh nauk]. 2018. Vol. 6, N 432. P. 77-84. (in Russ.). ISSN 2224-5278. <https://doi.org/10.32014/2018.2518-170X.37>

[7] Abhilash Sinha S., Sinha M.K., Pandey B.D. (2014) Extraction of lanthanum and cerium from Indian red mud // International Journal of Mineral Processing. 127: 70–73. <https://doi.org/10.1016/j.minpro.2013.12.009>

[8] Borra C.R., Mermans J., Blanpain B., Pontikes Y., Binnemans K., Van Gerven T. (2016) Selective recovery of rare earths from bauxite residue by combination of sulfation, roasting and leaching // Minerals Engineering. 92: 151-159. <https://doi.org/10.1007/s40831-016-0103-3>

[9] Ksenofontov B.S., Kozodaev A.S., Taranov R.A., Vinogradov M.S., Senik E.V., Voropaeva A.A. (2016) Rare-earth metals leaching from coal ash and their concentration // Safety in the technosphere [Vyshhelachivaniya redkozemel'nyh metallov iz ugol'noj zoly i ih koncentrirovaniye // Bezopasnost' v tehnosfere] 1:48-55. ISSN: 2307-0595

[10] Hammam-Nasri Ines, Horchani-naifer Karima, Ferid Mokhtar, Barca Donatella (2016) Rare earths concentration from phosphogypsum waste by two-step leaching method // Rare earths concentration from phosphogypsum waste by two-step leaching method. 149: 78-83. <https://doi.org/10.1007/s42250-019-00048-z>

[11] Todorovsky D., Terziev A., Milanova M. (1997) Influence of mechanoactivation on rare earths leaching from phosphogypsum // Hydrometallurgy. 45:13-19. <https://doi.org/10.1007/s12598-017-0952-3>

[12] Kenzhaliev B.K., Surkova T.Ju., Julusov S.B., Pirmatov Je.A., Dulenin A.P. (2017) Obtaining a concentrate of rare-earth elements from waste and industrial products of the uranium industry. Complex use of mineral resources [Poluchenie koncentrata redkozemel'nyh jelementov iz othodov i promproduktov uranovoj promyshlennosti Kompleksnoe ispol'zovanie mineral'nogo syr'ja] 1:70-77. [www.kims-imio.kz](http://www.kims-imio.kz)

[13] Bekturganov N.S., Najmanbaev M.A., Surkova T.Ju. (2010) Prospects for the development of the rare-earth sub-industry in Kazakhstan // Non-ferrous metals [Perspektivy razvitiya redkozemel'noj podotrasli v Kazahstane. Cvetnye metally] 4:48-50. ISSN: 0372-2929

[14] Uzhkenov B.S., Kajupov S.K. (2005) Technogenic mineral formations of mining enterprises, the possibilities of their use and geological and economic characteristics [Tehnogennye mineral'nye obrazovaniya predpriyatij gornopromyshlennogo proizvodstva, vozmozhnosti ih ispol'zovaniya i geologo-jekonomicheskaja harakteristika] Almaty.

[15] RMG 22772.4-96 Manganese udds, concentrates and agglomerates. Standards Publishing House [Rudy margancevyje, koncentraty i aglomeraty. Izdatel'stvo standartov] Minsk 1998.

[16] Lokshin Je.P., Taraeva O.A. (2008) Purification of phosphorus hemihydrate from phosphorus // Chemistry in the interests of sustainable development [Ochistka fosfopolugidrata ot fosfora // Himija v interesah ustojchivogo razvitiya]. T. 16. N 5. P. 553-558.

[17] Bol'shakov K.A. (1978) Chemistry and technology of rare and trace elements [Himija i tehnologija redkih i rassejannyh jelementov] M.: Vysshaja shkola 361 p.

[18] Turaev N.S., Zherin I.I. (2005) Chemistry and Technology of Uranium. CNIATOMINFORM [Himija i tehnologija urana. M.: CNIATOMINFORM], 407 p. ISBN 5-7262-0526-5

[19] Farmer V.C. (1974) «The Infrared Spectra of minerals», MINERALOGICAL SOCIETY, 41 QUEEN'S GATE. London, 539 p. ISBN 0903056054

[20] Nakamoto K. (1966) Infrared Spectra of Inorganic and Coordination Compounds: Translated from English [InfraKRasnye spektry neorganicheskikh i koordinacionnyh soedinenij: Per. s angl.] M.: Mir. 412 p.

[21] Kazicyna L.A., Kupletskaia N.B. (1971) The use of UV, IR and NMR spectroscopy in organic chemistry [Primenenie UF, IK i JaMR spektroskopii v organicheskoi himii], M., V.Sh., g. 264 p.

[22] Kenzhaliev B.K., Surkova, T.Y., Berkinbayeva, A.N., Dosymbayeva, Z.D., Chukmanova, M.T. (2019) To the question of recovery of uranium from raw materials News of the National Academy of Sciences of the Republic of Kazakhstan, Series of Geology and Technical Sciences 1 (433):112-119 <https://doi.org/10.32014/2019.2518-170X.14>

[23] Kenzhaliev B.K. (2019). Innovative technologies providing enhancement of non-ferrous, precious, rare and rare earth metals extraction. Complex Use of Mineral Resources [Kompleksnoe Ispol'zovanie Mineral'nogo Syr'a]. 3 (310), 64–75. Available at: <https://doi.org/10.31643/2019/6445.30>

[24] Kenzhaliev B.K., et al., (2019) To the question of the intensification of the processes of uranium extraction from refractory raw materials. Metalurgija, Vol. 58. P. 75-78.

[25] Kenzhaliev B.K., et al., (2019). Production of Very Fine, Spherical, Particles of Ferriferous Pigments from the Diatomaceous Raw Material of Kazakhstan. Glass and Ceramics, 76 (5-6), 194–198. Available at: <https://doi.org/10.1007/s10717-019-00163-w>

[26] Kapsalamova F.R., et al., (2019) Structural and phase transformations in wear resistant Fe-Ni-Cr-Cu-Si-B-C coatings. Journal of the Balkan Tribological Association, 25 (1). P. 95-103.

[27] Yessengaziyev A., et al., (2019) Research of the leaching process of industrial waste of titanium production with nitric acid. Journal of Chemical Technology and Metallurgy, 54 (5). P. 1061-1071.

[28] Koyzhanova A.K., et al., (2019). Research on the technology for recovering gold from spent heap leaching ore piles. Obogashchenie Rud. Vol. 2019, Issue 3, 2019. P. 54-59. Available at: <https://doi.org/10.17580/or.2019.03.09>

NEWS

OF THE NATIONAL ACADEMY OF SCIENCES OF THE REPUBLIC OF KAZAKHSTAN

SERIES OF GEOLOGY AND TECHNICAL SCIENCES

ISSN 2224-5278

Volume 2, Number 440 (2020), 96 – 102

<https://doi.org/10.32014/2020.2518-170X.36>

V. A. Kornev<sup>1</sup>, A. A. Makenov<sup>1</sup>, A. H. Mashekenova<sup>1</sup>, R. C. Radjabov<sup>2</sup>

<sup>1</sup>East Kazakhstan State Technical University, D. Serikbayeva, Ust-Kamenogorsk, Kazakhstan;

<sup>2</sup>Tadzhik State University of Commerce, Dushanbe, Tajikistan.

E-mail: kornev.44@list.ru, makenov\_a@mail.ru, assiya173@mail.ru, drrajab@mail.ru

## QUALITY ASSESSMENT OF MULTI-PARAMETER CONTROL OF VEHICLE COMPLEX SYSTEMS EFFICIENCY

**Abstract.** The aim of the study is to quantify and predict the risks of diagnosing multi-parameter systems of vehicle

*The object of research* is the process of technical maintenance of multi-agent systems.

*The subject of the research* is the process of quantitative evaluation and prediction of the risks of working capacity in the process of diagnosing vehicle multi-parameter systems.

To achieve goal the following aim is fulfilled in the article: sources of errors on the trajectory of the formation of the total measurement uncertainty were identified on the example of monitoring phase parameters of diesel engine fuel supply. A vehicle is considered as a complex multi-parameter multi-agent system with feedback to restore system performance. The control process is accompanied by errors in the form of a false and undetected defect. Probable errors determine risks of two types: risk of vehicle health checker and risk of a customer. For a quantitative assessment of these risks random and simulation models have been developed. Models allow to investigate the influence of statistical characteristics of modeling agents on control risks. For the integral assessment of the quality of maintenance, a “fuzzy” model and algorithm were developed by the example of the “personnel quality” criterion. Reliability and effectiveness of modeling is tested by a computer experiment based on a simulation approach. The developed mathematical model and simulation algorithm are universal and can be used in various scientific and technical practical applications. The authors proposed a new multi-approach method for quantitative assessment of decision-making risks in a multi-parameter control and management system using differentiated and integral functional indicators of the object under study.

**Key words:** vehicle, agent, system, model, probability, control, process, diagnostics, standard, accuracy, errors, risks.

**Introduction.** The performance of a complex system is an integrated composition of functional indicators taking into account the effects of the external environment [1-5]. The performance of the vehicle in accordance with the maintenance regulations is subject to periodic monitoring in order to quantify the compliance with the established standards (tolerances) of the current measured values of some of the most important technical and economic processes. From the stages of the car's life cycle, this paper considers the stage of its operation. From the point of view of system dynamics, this stage is a set of complex interconnected multi-agent processes United by a single goal [6]. In this composition of processes, it is necessary to distinguish the maintenance process (maintenance), which largely determines the economic, environmental and social indicators of vehicles. The main task is to maintain the operational reliability of the vehicle in the broad context of this requirement [7].

The maintenance process relies on knowledge from such subject areas as: mathematics, economics, management, diagnostics, ecology, computer science, artificial intelligence, etc. In this context, “agents” combine such properties and concepts as: software - hardware, technologically target entity; joint solution of a common problem through aggregation systems; inter-agent exchange of information and knowledge; providing local and aggregate robustness; modularity; system scalability and adaptability; multipath in the process of formalizing the functionality of agents; system openness [8,9].

The control system and support of the operational reliability of a vehicle should contain a monitoring that includes procedures (subprocesses) of measurement, comparison of the measured value with the

normative meaning and decision making [9]. The process of managing the operational reliability of a vehicle consists at least from the following agents: the object of control, control, analysis, decision-making and the agent for restoring the regulated functionality. The controlled parameters may have value of a specific physical quantity that in real conditions has a probabilistic nature, and be approximated by some distribution law  $f(x)$ . If it is not possible to measure a physical parameter directly we need to control its derivative called a diagnostic parameter  $S$ , which also has a probabilistic nature with a distribution density function  $f(S)$  [10].

**Scientific problem.** The measurement procedure in modern industrial and social technologies is often carried out by instrumental means, expert methods or their combination with technical means, and in some cases, especially in the control loop based on information systems that gives rise to the “human factor”.

It is traditionally considered that the determining factor in the assessment of the reliability of control is the measurement error. But as it shown above, control is a complex systemic composition of agents with non-linear characteristics. An important condition in many well-known technologies for diagnosing road transport is the absence of standards, but the recommended technical conditions for carrying out diagnostic work and the regulatory framework are based on statistical data that suffer extreme heterogeneity, which makes the results of monitoring substantially uncertain. All of this led to the idea to use uncertainty as a measure of accuracy [11,13].

Modern methods of integrated assessment of vehicle performance include the use of complex diagnostic systems. Diagnostic algorithm appears to be a fuzzy multiparameter process. In such systems, a differentiated approach is used to assess the diagnostic qualities of the parameters according to their informativeness about the technical and economic performance of the engine. They are: environmental friendliness, connection with vehicle operational safety and fuel consumption. It is usual to proceed from their own experience and preferences to determine the optimal set of diagnostic parameters, especially in practice. Some studies recommend to use the methods of expert assessments and to determine the weight of individual diagnostic parameters. Therefore, there is a need to use some integral indicators calculated by factor aggregates using the fuzzy sets apparatus, leaned on linguistic qualitative assessments [9].

**Research methods.** A systematic approach was used as a methodological base for research. Within the scope of theoretical studies, scientific hypotheses were put forward, the purpose, criteria and objectives of research were determined. Formalization tool like a multi-approach methodology involving expert estimation, the theory of fuzzy sets, mathematical statistics, agent-based and simulation modeling are suggested. A wide range of sections including mathematical apparatus is because the task has a semi-structured and multifactorial type and the modeling is carried out under conditions of statistical uncertainty.

**Research result.** The model of structural uncertainty, based on the example of measuring the most important diagnostic parameter of a diesel engine - the fuel injection advance angle, is formed by the following sources:  $\sigma_1$  - error of applying the base mark (marks on the crankshaft pulley);  $\sigma_2$  - the error of applying the base label (marks on the crankcase);  $\sigma_3$  - TDM sensor installation error;  $\sigma_4$  - the error determined by the instability of the speed mode of rotation of the engine crankshaft;  $\sigma_5$  - error due to the dynamic instability of the fuel supply process;  $\sigma_6$  - error of visual fixation of dynamic marks (in stroboscopic measurements);  $\sigma_7$  - error of reading information (in analog devices).

These structural components are of a statistical nature, independent and uncorrelated. The first two uncertainties are determined by factory documentation. Then, the resulting uncertainty is estimated from the expression  $\sigma_\Sigma = \sqrt{\{\sigma_i^2\}}$ .

Control risk modeling with one limit standards. Let's consider some conventional complex multi-parameter system quality control. As functional processes, measurement and decision making are investigated. In this task, the control process is considered as a multi-agent system, where agents should be distinguished: agent - external environment; agent - object of control; agent - the measurement process; agent - standard consumption; agent - decision making system.

Process quality indicators, according to existing technical regulations, should not exceed some of the permissible standards. Standards (limits) can be one-sided (top or bottom) and two-sided. The case of two-sided limitation is called limiting.

Mandatory control procedure is measurement. Measurement is considered as an independent agent, which possesses characteristics independent in the control process - the distribution law and the

corresponding statistical characteristics. During the research of a multi-agent system, these characteristics may vary in order to find the optimal values. This approach is applicable and to other agents.

The term and technological procedure “measurement” in this context can be understood broadly for any object (parameter, process, event) regardless of its nature [12]. Under the measuring instruments (meter, “device”) there can be physical instruments, instruments and methods of measurement, methods and resources for identifying data on documents, the subject and the resources used to identify the necessary information. The result of the measurement is always a number (or a set of numbers), giving a quantitative estimate of the measured value in some pre-selected units. The set of measurement results is the set of numbers from a certain range of possible values.

As shown above, control is a sequence of measurement procedures, comparing the measured value with the standards and making decisions based on the principle “a controlled object is suitable”, “a controlled object is unsuitable”. The final decision "suitable-unsuitable", as a rule, generally accepted by man.

Due to the fact that the measurement process is accompanied by random errors, control errors occur. Control errors are usually divided as false and undetected defects (false and undetected failures). Quantitatively, these errors are estimated by the corresponding probabilities, in this case,  $P_{fd}$  is the probability of a false defect and  $P_{ud}$  is the probability of an undetected defect. These probabilities are also sometimes given a sense of the risks of the producer of the work and the customer of the work, respectively.

In this way, initially there arises the general task of developing mathematical models for the quantitative estimation of these errors (risks) as a function of the statistical characteristics of all components of the multi-agent model: measurements, standards, and decision-making procedures. At the first stage of modeling it is considered that the standards are deterministic values.

For an integral assessment of the quality of measurement information, reliability as an indicator is often used. The reliability of the control is the degree of confidence that the measured values truly reflect the object's state of interest [9]. The expression for assessing the reliability is as follows:

$$D = 1 - (P_{fd} + P_{ud}).$$

The case of a single-limit restriction of the controlled parameter  $S$  “from below” by the standard  $S_n$  will be considered as the first variant of the model. From a probabilistic point of view, we will be interested in two events:

- the true value of the parameter is higher than the standard ( $S_i > S_n$ ), i.e., the monitored parameter is normal (fit), and the measured value as a result of random error turned out to be lower than the standard ( $S_{imeasur} < S_n$ ) (not valid), which is a false marriage;
- the true value of the parameter is lower than the standard ( $S_i < S_n$ ), i.e., the monitored parameter is in the "invalid" field, and the measured value as a result of random error turned out to be higher than the standard ( $S_{imeasur} > S_n$ ) (valid), which is an undetected marriage.

Initially assumed that distribution densities of the monitored parameter  $f(S)$  and random error  $j(y)$  are approximated by normal laws. Then the expressions for estimating the probabilities  $R_{lb}$  and  $R_{nb}$  will have the following form.

$$P_{fd} = \sum_{t=1}^n \frac{1}{\sqrt{2\pi}} \int_{t_i}^{t_{i+1}} e^{-\frac{t^2}{2}} dt \cdot \frac{1}{\sqrt{2\pi}} \int_{-\infty}^{z_i} e^{-\frac{z^2}{2}} dz \quad (1)$$

The expression for estimating undetected defect  $P_{nb}$  will be:

$$P_{ud} = \sum_{t=1}^n \frac{1}{\sqrt{2\pi}} \int_{t_i}^{t_{i+1}} e^{-\frac{t^2}{2}} dt \cdot \frac{1}{\sqrt{2\pi}} \int_{z_i}^{+\infty} e^{-\frac{z^2}{2}} dz \quad (2)$$

The variable  $t$  is a centered variable with respect to the average value of the monitored parameter and normalized with respect to the standard deviation (uncertainty). The variable  $z$  is the normalized quantity with respect to the standard deviation of the density function of the measurement error distribution.

Analytical models (1) and (2) allow to investigate and quantify the impact of all statistical characteristics of the control system on the likely risks of  $P_{fd}$ ,  $P_{ud}$  and reliability  $D$ .

In the study of more complex processes, such as tolerance control, the probabilistic model is burdened by additional sources of computational errors. In this case, the most acceptable and effective method for modeling control errors under tolerance standards, as established by the authors, is the use of simulation modeling. The simulation model algorithm for this case contains:

The first block is the input of the initial statistical characteristics of the laws of distribution and the number of simulation cycles -  $N$ . The second, third and fourth blocks, as follows from the explanations in the blocks, are random number generators. Blocks 5 and 6 contain the logical condition  $IF$  (branching)  $V_l < V_i < V_u$  and  $V_l < V_{imea} < V_u$ .

Blocks 7 and 9 are event counters. In block 10, the calculation of the risks of  $R_{fd}$  and  $R_{ud}$  is carried out, and in block 11, the integral indicator of the quality of control is calculated - reliability.

In the results of a computer experiment, it was found that the probability of a false defect of  $R_{fd}$  is most affected. If the value of measurement uncertainty  $\sigma_\phi$  is comparable with the value of  $\sigma_s$ , the risk can reach 25%. At the same time, it was found that the impact of variation in standards on reliability is significantly higher than the effect of measurement uncertainties. Analysis of the simulation data showed that the systematic relationship of the statistical characteristics of the process and control parameters leads to non-linear results and eliminates the possibility of linear quantitative predictions of reliability and control risks. Effective design of such systems is provided by formal methods implemented in the form of software applications. The results obtained are extremely important when choosing alternatives in the control paradigm, it means which one should prefer the accuracy parameters of the instruments or the regulatory framework.

Based on the research results, the following conclusions can be drawn:

To control the quality of decision making in a complex multi-parameter system, to increase the reliability and efficiency of this process, it is necessary to involve formal mathematical and simulation methods. In the quality management of multi parameter systems, the control process plays a crucial role, at which stage management risks are formed. It is rational to control by two algorithms: differentiated according to the set of indicators of the quality of system functioning and on the basis of an integral indicator that aggregates differentiated estimates in the form of convolution. The control contains procedures: measurements, comparison of the measured result with the standard, decision making. Risks are control errors and are quantified by the probability of a false defect and the probability of an undetected marriage. For the quantitative measurement of control errors in the work, probabilistic and simulation models of estimating confidence, as well as false and undetected defects are proposed. For theoretical modeling and practical use in the design of complex diagnostic systems, a software package has been developed. The results of computer simulation showed the following:

1. The analysis of computer-aided customer risk assessment data also confirms the presence on the surface of the response line of the maximum, passing for the case of a normal distribution of  $Y$  and  $S$  at values of 10.58%, 16.5%, 25.95%, 27.05%, 29.63%, 31.3%. For the case of the distribution of  $Y$  under the normal, and  $S$  under the uniform laws, the maximum values are 5.5%, 11.5%, 14.5%, 16.9%, 18.8%, 21.3%.

2. Simulation of the manufacturer's risk level confirms that there is a maximum value that corresponds to the values of 10.85%, 19.25%, 23.9%, 28.85%, 30.8%, 34%, but for the values of  $S_{av}$ , equal to 1.3 and 1.4. For the case of a normal distribution of  $Y$  and a uniform distribution of  $S$ , the maximum values are 5.9%, 12.4%, 19.4%, 25%, 29.6%, 29.7%, respectively, to the levels of variation indicated above. The maximum corresponds to the average value of  $S$ , equal to 1.5.

3. The loss level for the uniform distribution law  $S$  is lower than for the normal law and the maximum value shifts towards a larger value of the average value  $S$ , which has a certain economic meaning in the process of implementing the decisions. The mathematical explanation of the presence of mini - max levels can be considered as a consequence of the conjugation of two smooth nonlinear forms, as a result of which a third, clearly nonlinear form is generated.

В. А. Корнев<sup>1</sup>, А. А. Макенов<sup>1</sup>, А. Х. Машекенова<sup>1</sup>, Р. К. Раджабов<sup>2</sup>

<sup>1</sup>Д. Серікбаев атындағы Шығыс-Қазақстан мемлекеттік техникалық университеті, Өскемен, Қазақстан;

<sup>2</sup>Тәжик мемлекеттік университеті, Душанбе, Тәжікстан

### АВТОМОБИЛЬДІҢ КҮРДЕЛІ ЖҮЙЕЛЕРІНІҢ ЖҰМЫСҚА ҚАБІЛЕТТІЛІГІНІҢ МУЛЬТИКӨРСЕТКІШТІК БАҚЫЛАУЫНЫҢ САПАСЫН БАҒАЛАУ

**Аннотация.** *Зерттеудің мақсаты* автомобиль жүйелерінің көпкөрсеткіштік диагностикалауының тәуекелдігін болжау мен сандық бағалау болып табылады.

*Зерттеудің нысаны* көпагенттік жүйелердің техникалық қамтамасыз етуінің үрдісі болып табылады.

*Зерттеудің пәні* автомобильдің көпкөрсеткіштік жүйелерін диагностикалау үрдісіндегі жұмысқа қабілеттілікті бақылау тәуекелдігін болжау мен сандық бағалау үрдісі болып табылады.

Қойылған мақсатқа жету үшін мақалада міндеттер шешілді: дизель қозғалтқышының отын беруінің фазалық көрсеткіштерін бақылау мысалында өлшеудің жиынтық белгісіздігін қалыптастыру траекториясында дәлсіздік көздерін анықтаған.

Техникалық қызмет көрсету регламенттеріне сәйкес автомобильдің жұмысқа қабілеттілігі кейбір неғұрлым маңызды техникалық-экономикалық үрдістердің ағымдағы өлшенетін мәндерінің белгіленген нормативтерге (рұқсаттарға) сәйкестігін сандық бағалау мақсатында ағымдық бақылауға жатады. Бұл жұмыста автомобильдің өмірлік циклінің кезеңдерінен оны пайдалану кезеңі қарастырылады.

Бақылау үрдісінің алгоритмі бақыланатын көрсеткіштің қасиеттері мен мәндеріне, нормативтік мәндерге, талдау әдісі мен құралдарына және шешім қабылдау жүйесіне байланысты болады. Егер нормативтік функцияларды қалпына келтіру қажеттігі туралы шешім қабылданса, онда объектіге кері байланыс нысанында реттеу (түзету) әсері қолданылады. Кері байланыс барлық техникалық қызмет көрсету үрдісінің түпкілікті нәтижелілігін анықтайды, өйткені кері байланыссыз басқару барлық мағынасын жоғалтады және болып жатқан жағдайды жай ғана ойлауға айналады.

Автомобильге техникалық қызмет көрсетудің соңғы нәтижесі пайдалану сенімділігін арттыруға, экологиялық қауіптілікті төмендетуге және үнемділігін арттыруға бағытталуы тиіс. Көпкөрсеткіштік диагностика осы міндеттерді шешудегі тиімді құрал болып табылады. Сонымен қатар, жоғарыда көрсетілген өлшемдер бойынша диагностикалық кешенді объективті таңдау әдістемесі іс жүзінде жоқ. Келтірілген мәселе бойынша шешім қабылдаудың объективтілігі мен сапасы қолда бар техникалық базаны пайдалану тәуекелдерін бағалауға және зерттелетін мәселені шешуде инновациялық техникалық-ұйымдастырушылық тәсілдерді енгізу кезінде оларды болжауға мүмкіндік беретін формальды құралдарды енгізу жолымен жоғарылауы мүмкін.

Күрделі көпкөрсеткіштік жүйеде шешім қабылдау сапасын басқару, осы үрдістің нақтылығы мен жеделдігін арттыру үшін формальды математикалық және имитациялық әдістерді тарту қажет. Көпкөрсеткіштік жүйелердің сапасын басқаруда бақылау үрдісі шешуші рөл атқарады, оның кезеңінде басқару тәуекелдері қалыптасады.

Автомобиль, жүйенің жұмысқа қабілеттілігін қайта қалпына келтіру мақсатында кері байланысы бар күрделі көпкөрсеткіштердің көпагенттік жүйе ретінде қарастырылады. Бақылау үрдісіне жалған және табылмаған ақау түріндегі қателер жатады. Ықтимал қателер екі түрдегі тәуекелдерді анықтайды: диагностикалық жұмыстарды өндірушінің тәуекелі және жұмыстарға тапсырыс берушінің тәуекелі. Көрсетілген тәуекелдерді сандық бағалау үшін ықтималдық және имитациялық үлгілер жасалынды. Үлгілер үлгілеу агенттерінің статистикалық сипаттамаларының бақылау тәуекелдеріне әсерін зерттеуге мүмкіндік береді. Техникалық қызмет көрсету жүйесінің сапасын интегралдық бағалау үшін «анық емес» үлгі және «персоналдың сапасы» критерийі мысалында алгоритм әзірленді. Үлгілеудің дұрыстығы мен нәтижелілігі имитациялық тәсіл негізінде компьютерлік экспериментпен тестіленеді. Әзірленген математикалық үлгі және имитациялық алгоритм әмбебап сипатқа ие және әртүрлі ғылыми-техникалық тәжірибелік қосымшаларда қолданылуы мүмкін. Авторлармен зерттелетін объектінің дифференциалды және интегралды функционалдық көрсеткіштері бойынша көппараметрлік бақылау және басқару жүйесінде шешім қабылдау тәуекелдерін сандық бағалаудың жаңа көптәсілді әдістемесі ұсынылды.

**Түйін сөздер:** автокөлік, агент, жүйе, үлгі, ықтимал, бақылау, үрдіс, диагностика, нормативті, шынайы, қателер, тәуекел.

В. А. Корнев<sup>1</sup>, А. А. Макенов<sup>1</sup>, А. Х. Машекенова<sup>1</sup>, Р. К. Раджабов<sup>2</sup>

<sup>1</sup>Восточно-Казахстанский государственный технический университет им. Д. Серикбаева,  
Усть-Каменогорск, Казахстан;

<sup>2</sup>Таджикский государственный университет, Душанбе, Таджикистан

## ОЦЕНКА КАЧЕСТВА МУЛЬТИПАМЕТРИЧЕСКОГО КОНТРОЛЯ РАБОТОСПОСОБНОСТИ СЛОЖНЫХ СИСТЕМ АВТОМОБИЛЯ

**Аннотация.** *Целью исследования* является количественная оценка и прогнозирование рисков диагностирования многопараметрических систем автомобиля.

*Объектом исследования* является процесс технического обслуживания многоагентных систем.

*Предметом исследования* является процесс количественной оценки и прогнозирования рисков контроля работоспособности в процессе диагностирования многопараметрических систем автомобиля.

Для достижения поставленной цели в статье решены задачи: выявление источников погрешностей на траектории формирования суммарной неопределенности измерения на примере контроля фазовых параметров топливopодачи дизельного двигателя.

Работоспособность автомобиля в соответствии с регламентами технического обслуживания подлежат периодическому контролю с целью количественной оценки на соответствие установленным нормативам (допускам) текущих измеряемых значений некоторых наиболее важных технико-экономических процессов. Из этапов жизненного цикла автомобиля в данной работе рассматривается этап его эксплуатации.

Алгоритм процесса контроля зависит от свойств и значений контролируемого параметра, нормативных значений, метода и средств анализа и системы принятия решения. Если принимается решение о необходимости восстановления нормативных функций, то предпринимаются регулировочные (корректирующие) воздействия на объект в форме обратной связи. Обратная связь определяет конечную результативность всего процесса технического обслуживания, так как без обратной связи управление теряет всякий смысл и превращается в созерцание происходящего.

Конечный результат технического обслуживания автомобиля должен быть нацелен на повышение эксплуатационной надежности, снижения экологической опасности и повышения экономичности. Многопараметрическая диагностика является в некотором объеме эффективным инструментом в решении этих задач. Вместе с тем, методика объективного выбора диагностического комплекса по указанным выше критериям практически отсутствует. Объективность и качество принятия решения по приведенной проблематике может быть повышены путем внедрения формальных инструментов, которые предоставят возможность оценивать риски использования имеющейся технической базы и прогнозировать их при внедрении инновационных технико-организационных подходов в решение исследуемой проблемы.

Для управления качеством принятия решений в сложной многопараметрической системе, повышения достоверности и оперативности этого процесса необходимо привлекать формальные математические и имитационные методы. В управлении качеством многопараметрических систем решающую роль играет процесс контроля, на этапе которого формируются риски управления.

Автомобиль рассматривается как сложная многопараметрическая многоагентная система с обратной связью с целью восстановления работоспособности системы. Процессу контроля сопутствуют ошибки в форме ложного и необнаруженного брака. Вероятные ошибки определяют риски двух типов: риск производителя диагностических работ и риск заказчика работ. Для количественной оценки указанных рисков разработаны вероятностные и имитационные модели. Модели позволяют исследовать влияние статистических характеристик агентов моделирования на риски контроля. Для интегральной оценки качества системы технического обслуживания разработана «нечеткая» модель и алгоритм на примере критерия - «качество персонала». Достоверность и результативность моделирования тестируется компьютерным экспериментом на базе имитационного подхода. Разработанная математическая модель и имитационный алгоритм носят универсальный характер и могут использоваться в различных научно-технических практических приложениях. Авторами предложена новая многоподходная методика количественного оценивания рисков принятия решений в многопараметрической системе контроля и управления по дифференцированным и интегральным функциональным показателям исследуемого объекта.

**Ключевые слова:** автомобиль, агент, система, модель, вероятность, контроль, процесс, диагностика, норматив, достоверность, ошибки, риски.

**Information about the authors:**

Kornev Vyacheslav Andreevich, Candidate of Technical Sciences, Professor of the department «Instrument Engineering and Technology Automation», D. Serikbayev East Kazakhstan state technical university, Ust-Kamenogorsk, Kazakhstan; kornev.44@list.ru; <https://orcid.org/0000-0002-0151-0905>

Makenov Altay Abylayevich, Candidate of Technical Sciences, Professor of the department «Mechanical engineering» D. Serikbayev East Kazakhstan state technical university, Ust-Kamenogorsk, Kazakhstan; makenov\_a@mail.ru; <https://orcid.org/0000-0002-6702-0212>

Mashekenova Assiya Hassenovna, Candidate of Technical Sciences, Head of the sub-department «Mechanical engineering» D. Serikbayev East Kazakhstan state technical university, Ust-Kamenogorsk, Kazakhstan; assiya173@mail.ru; <https://orcid.org/0000-0003-3556-3033>

Radjabov Rajat Cuchacovich, Doctor of Economics Sciences, Professor, vice-rector for scientific work Tadzhih State University of Commerce, Dushanbe, Tajikistan; drrajab@mail.ru; <https://orcid.org/0000-0001-8115-4295>

**REFERENCES**

[1] Viktorova V.S. Models and methods for calculating the reliability of technical systems / V.S. Viktorova, A.S. Stepanyants. M.: URSS Publishing Group, LENAND LLC, 2016. 256 p.

[2] Dillon B. Engineering methods for ensuring the reliability of systems: Trans. from English / B. Dillon, C. Singh. M.: Mir, 1984. 318 p.

[3] Konesov S.G., Khaziyev R.T. Methods for assessing the reliability of complex components and systems // Modern problems of science and education. 2015. N 1-1; URL: <http://www.science-education.ru/ru/article/view?Id=17558> (appeal date 09/28/2018)

[4] Shishmarev V.Yu. Reliability of technical systems: Reliability of technical systems: Textbook for universities / V.Yu. Shishmarev. M.: ITS "Academy", 2010. 304 p.

[5] Henley E.J. Reliability of technical systems and risk assessment / E.J. Henley, H. Kumamoto. M.: Mashinostroenie, 1984. 528 p.

[6] Birolini A. (2010) Reliability Engineering: Theory and Practice. 6th Springer-Verlag: Berlin, Heidelberg, 2010. 610 p. ISBN: 978-3-642-14952-8

[7] Knutelska M. (2010) Evaluating The Operational Reliability of Road Vehicles. Proceeding of the X International Conference on Reliability and Statistics in Transportation and Communication, 20-23 October 2010, Riga, Latvia, P. 66-70. ISBN: 978-9984-818-34-4

[8] Kolowrocki K. (2014) Reliability of Large and Complex Systems. 2th edition. Elsevier, Heidelberg, 2014. 460 p. ISBN: 978-0-08-099949-4

[9] Kornev V.A., Makenov A.A. Modern methods of modeling decision-making processes in control systems: Monograph. Ust-Kamenogorsk: Publishing house of EKSTU, 2008. 148 p.

[10] Multi-agent system. [https://en.wikipedia.org/wiki/Multi-agent\\_system](https://en.wikipedia.org/wiki/Multi-agent_system)

[11] Radjabov R.K., Kornev V.A., Makenov A.A., Morozova O.V., Zubaidov S. Modeling microeconomics: Monograph. Dushanbe: Irfon, 2017. 332 p.

[12] Guide to the Expression of Uncertainty in Measurement. (Guide to the expression of uncertainty of measurement) International Organization for Standardization, CHF 92. ISO, Case postale 56, CH-1211 Geneva, Switzerland.

[13] Akhmetov B.S., Akhmetov B.B., Lakhno V.A., Malyukov V.P. Adaptive model of mutual financial investment procedure control in cybersecurity systems of situational transport centers// Bulletin of national academy of sciences of the Republic of Kazakhstan. Vol. 3, N 435 (2019), 159–172. <https://doi.org/10.32014/2019.2518-170X.82>. ISSN 2224-5278.

**NEWS**

OF THE NATIONAL ACADEMY OF SCIENCES OF THE REPUBLIC OF KAZAKHSTAN

**SERIES OF GEOLOGY AND TECHNICAL SCIENCES**

ISSN 2224-5278

Volume 2, Number 440 (2020), 103 – 113

<https://doi.org/10.32014/2020.2518-170X.37>

UDC 551.49:(556.3)

**E. I. Lagutin<sup>1</sup>, V. A. Smolyar<sup>2</sup>, K. A. Kojobaev<sup>3</sup>, A. G. Terekhov<sup>4</sup>, M. B. Edigenov<sup>5</sup>**<sup>1</sup>Institute of Water Problems and Ecology, Taraz, Kazakhstan;<sup>2</sup>Institute of Hydrogeology and Geoecology, Almaty, Kazakhstan;<sup>3</sup>Kyrgyz-Turkish "Manas" University, Bishkek, Kyrgyz Republic;<sup>4</sup>Institute of information and computing technologies CS MES RK, Almaty, Kazakhstan;<sup>5</sup>LLP "Scientific-production firm Geoekos", Kostanai, Kazakhstan.E-mail: eliktz4065@mail.ru, v\_smolyar@mail.ru, kojkanik@gmail.com,  
kanatbek.kojobaev@manas.edu.kg, aterekhov1@yandex.ru, edigenov@mail.ru**RK PROBABILISTIC HYDROGEOLOGICAL MAP**

**Abstract.** Hydrogeological maps are currently one of the most important elements of the image of the hydrogeological situation in both regional and local representation. In accordance with the existing instructions, they are compiled on the basis of topographic, geological and tectonic maps of various scales based on the results of hydrogeological surveys and reflect the boundaries of the distribution of aquifers and complexes, confined, as a rule, to geological-stratigraphic and tectonic formations and their real manifestations on the ground (sources, wells, drilling wells). In addition to the General hydrogeological maps described above, special hydrogeological maps and sections are compiled that reflect the individual sides of the hydrogeological process – maps of the depths of the groundwater level, maps of the filtration properties of the host rocks, maps of the water supply and the level of aquifers, maps of the chemical composition of groundwater and others.

All the above-mentioned hydrogeological maps and sections are static and do not reflect the dynamics of the hydrogeological process in time. They only reflect on the geological and tectonic basis obtained during the hydrogeological survey process one-time field initial hydrogeological parameters (flow rates of individual sources and hydrogeological wells, the chemical composition and physical quality of groundwater, some hydrogeological parameters of aquifers). For these reasons, they can not serve as a benign basis for predicting the further development of the hydrogeological process. Forecast hydrogeological calculations based on such initial data are not characterized by high accuracy and reliability, usually not higher than 15-30%.

In the present article on the basis of our own research we propose new principles and provide specific examples of building a fundamentally different type of hydrogeological maps that reflect the dynamics of the hydrogeological process in time, significantly increasing the accuracy and reliability of predictive hydrogeological calculations and hydrogeological-reclamation forecasts (up to 1-5%). Such maps are built on the basis of long-term monitoring data on the regime of groundwater and its chemical composition, pre-processed using mathematical methods of probability theory and the theory of random functions on the actual material typical for the South of Kazakhstan Tashutkul Irrigation massif. As a result, probabilistic hydrogeological maps of the position of groundwater levels, aquifer capacity, groundwater resources of varying degrees of security (5, 25, 50, etc.,%) were obtained. Received cards of various types of probability distribution and forecasting of hydro-geological process, etc. In such complex probabilistic hydrogeological maps are sufficiently benign basis for prediction of the hydrogeological-reclamation situation on irrigated tracts and can serve as a reliable basis for projecting the resource potential of the groundwater of certain regions and social formations.

**Key words:** Existing hydrogeologiczny maps, cross sections. Static maps. Insufficient accuracy of existing hydrogeological calculations and forecasts. Probabilistic hydrogeological maps. Monitoring baseline data. Methods of probabilistic data processing. Significantly improved the accuracy of hydrological calculations and drainage-hydrological forecasts.

**Introduction.** The deterioration of irrigated land in Kazakhstan [2,10,14,17,22,31] requires the search for new, more economical methods and technologies of irrigation, and in addition new, primarily local sources of irrigation water. This category includes groundwater with significant potential resources

in Kazakhstan [2,8,9,14,17,19-22,31]. Analysis of the publications known in the scientific literature [3,4,7,6,11,13,17,19,21-23,32,34,39-43] shows that despite the abundance of calculation formulas and methods, a number of important issues arising in the calculation and design of vertical drainage on irrigated areas and in the use of groundwater for irrigation remains to this time insufficiently studied. These include: the need to take into account the regime of irrigation water infiltration at the upper boundary of the flow, the definition of inter-drainage distances, taking into account the boundary hydrogeological conditions, the definition of the reclamation effect of water intake, taking into account changing natural and anthropogenic conditions.

Outlined above specific scientific issues addressed in the process of implementing a special State research program for the study of the state Testconsole array of irrigation, which are typical for arrays of river valleys and rivers of southern Kazakhstan (figure 1). As a result of improper operation of irrigation systems there is a progressive rise of groundwater levels predetermining further salinization of soils and groundwater [5,7,22,17]. Hydrogeological parameters of aquifers and hydrogeological wells were investigated on the site of the existing vertical drainage in the novotroitskiy state farm in the field, water balance observations and studies were carried out. As a result, the discrepancy of hydrogeological parameters was established, obtained from surveys and data exploitation. The material on the regime of groundwater for the entire available observation period (5-25 years) was collected and generalized for a total of 256 observation points.

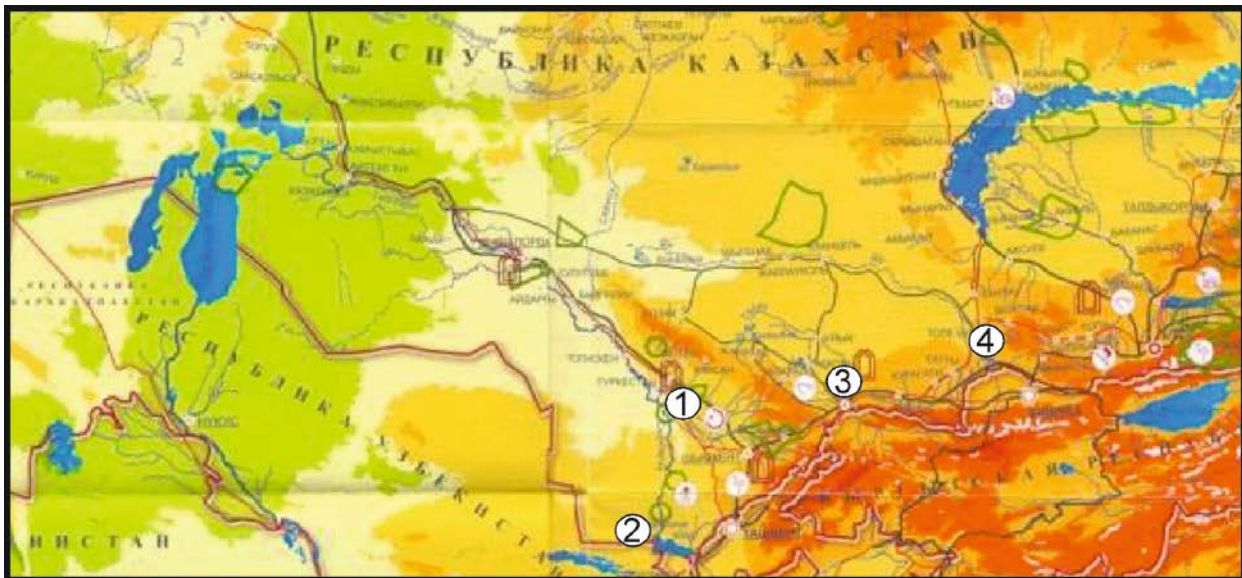

Figure 1 – Physical and geographical map of southern Kazakhstan. Main irrigation areas:  
1-Kyzylkum, 2 - Arys Turkestan, 3 - Talas, 4 - Tashutkul

On the basis of the statistical analysis of the data of regime observations, probabilistic and statistical maps of groundwater levels, evaporation power and resources of different availability were constructed. On the basis of the use of the materials of such maps, a method for calculating the supply at the upper boundary of the groundwater aquifer and the use of this value in the calculations of groundwater intakes [6,17,22] has been developed. Water balance studies have shown that in irrigated areas more than 90% of groundwater supply is lost from irrigation networks and irrigation fields. When using the developed original scheme of water management calculation of vertical drainage on the irrigation massif, irrigation water saving will be up to 20 - 30% with simultaneous improvement of reclamation and hydrogeological conditions. Been zoning Testconsole array of irrigation in terms of application of the developed methods of calculation of underground water intake [17,22,41].

**Methods of work.** In accordance with the currently existing instructions [24-30,35] hydrogeological maps are compiled on the basis of topographic, geological and tectonic maps of different scales on the results of hydrogeological surveys and reflect the boundaries of the distribution of aquifers and complexes, confined, as a rule, to geological-stratigraphic and tectonic formations and their real

manifestations on the ground (sources, wells, boreholes). They are simultaneous, static, to a certain extent random.

In our studies, forecast probabilistic and statistical maps were built on the basis of probabilistic and statistical analysis of monitoring data on the network of observation wells. Generally, a series of observations of at least 10 years in length for each well is recommended. The accuracy and reliability of the maps themselves is determined by the density of the observation network. For maps of scale 1:100000 the density of the reference (opened underground water) network is considered sufficient in the presence of an average of one point per 1km<sup>2</sup>. with a sparser grid mapping schema. Points with short series of observations in our case resulted in a long representative series of wells with similar hydrogeological conditions. Then, using the research methodology of the statistical population, we obtained the theoretical law of probability distribution corresponding to the essence of the process [15,16,18,22,36,37]. On integral curves of securities calculated the value of the securities of the depths to the water at each observation well.. Under normal and lognormal laws, probabilistic paper (Hazen fiber) was used, on which the curves acquire the character of straightened lines [36,37].

The most important hydrogeological information for the preparation of various water management projects is usually contained in the level maps 1-,5-,50-,75-,95%-of security or repeatability in 1, 5, 20, 50 times per 100 years. Having a corresponding distribution curve for each well, we obtain depths corresponding to the probability of repetition in a given number of years. Thus, groundwater levels of 50 % of availability serve as a source material for mapping the average annual depth of groundwater. Of particular note are forecast maps of the depths of groundwater of rare occurrence (1 every 100 years). Such levels are usually not practically observed, but which can be expected with security of 1 and 99 %.

In principle, it is possible and practical to draw up probabilistic and statistical maps of other hydrogeological parameters - amplitudes of fluctuations in levels, resources, supply and evaporation of groundwater to others, some of them are given below. The principles of their construction are similar.

**The analysis of the actual predictive probability and statistical cards for example Testconsole array of irrigation.** The starting material for predictive probabilistic and statistical maps of hydrogeological parameters for the site Testconsole array of irrigation, based on data from regime observations for 230 wells network Dzhambul hydro-geological expedition of the Kazakh SSR MG (66 SLE.), Chinkent hydrogeological expedition reclamation of Gavrilovskaya Mivh of the USSR (110 SLE.) and Dzhambul of oblselvodkhos of the Kazakh SSR (54 SLE.). The longest series of observations were available for wells DGE (average 10-25 years), slightly lower (up to 5-8 years) on the network CHGME and the least long (up to 3-5 years) on the network Dzhambul regional meliovodkhoz. The latter were used only for data interpolation and boundary refinement (figure 2, table 1).

Table 1 – The depth of groundwater levels of different security in the territory Testconsole array of irrigation (km<sup>2</sup>/ %)

Provision, %	Groundwater levels, m			
	0 - 1	1 - 3	3 - 5	>5
1	70 10,1	461 70,2	61 9,2	71 10,3
5	36 5,4	445 67,1	72 10,8	100 15,0
25	25 3,77	434 65,5	94 14,8	110 16,1
50	12 1,8	370 55,8	144 21,8	137 20,6
75	10 1,6	276 41,6	251 38,6	131 19,8
95	8 1,2	224 36,8	270 40,2	141, 21,7
99	–	208 32,5	265 40,0	190 27,5

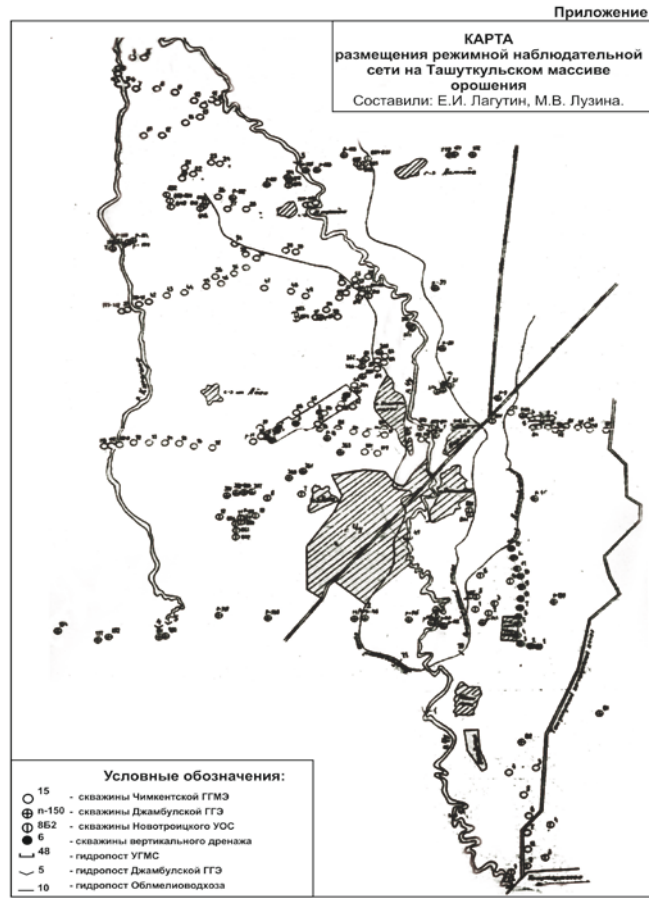

Figure 2 – Map of the location of the monitoring network on the Tashutkul irrigation array. Made: E.I. Lagutin, M.V. Luzina

With the area of the characterized part of the array about 37 thousand hectares (see table 1), the density of the observation network is about 6.1 points per 10 km<sup>2</sup> of array area, including about 1.4 representative points with long-term series of observations. This ensures the reliability of hydrogeological parameters in relation to the scale of about 1:50000.

In figures 2-6 shows maps of groundwater levels of the Central part of the array Testconsole irrigation of various degrees of security. For the comparative analysis the generally accepted gradations of depth of groundwater levels - up to 1 meter, 1 - 3 m, 3 - 5 m and more than 5 meters were chosen. In table 1 it is shown that with the increase of security (maximum depth) levels vary significantly, so 1 every 2 years (50 % security) groundwater levels up to 3 meters occupy 58 % of the area. Other depths (3-5 m and more than 5 m) occupy about 40 %, 1 time in 20 years close (up to ZM) occurrence is possible by 73 %, and 1 time in 100 years these areas are about 90 %, including depths up to 1 meter are assumed to 0.1 % of the area. On the contrary, with high reliability in 19 years out of 20, depths up to 1 meter occupy about 1%, 1-3 to 38.8% of the area. About 60 % of the area is characterized by a depth of more than 3 meters.

It should be noted that the concept of "security of the process" in refraction to the assessment of groundwater levels is somewhat different from that adopted in hydrology. A wide variety of cutting factors and their combinations determine the diversity of their impact on groundwater levels over time and the corresponding diversity of the distribution of the process security over the area of the massif. for rice.3-4 two maps are presented: a Map of the depth of groundwater levels of Tashutkul massif on a specific date - March 1 and a Map of statistical security (%) of groundwater levels on the same date.

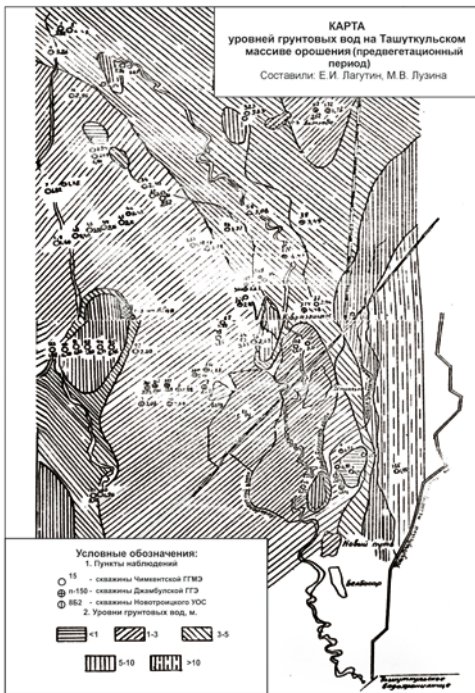

Figure 3 –  
Map of groundwater levels in the array Testcursor irrigation (pre-vegetation period).  
Made: E.I. Lagutin, M.V. Luzina

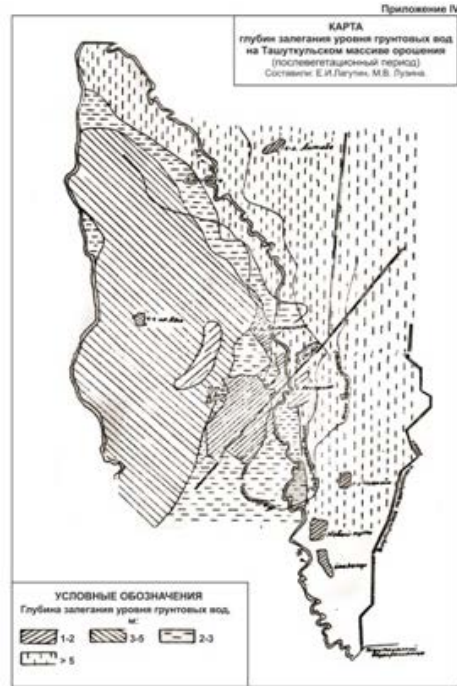

Figure 4 –  
Map of probabilities of exceedance levels of groundwater Testcursor array of irrigation (after the vegetation period).  
Made: E.I. Lagutin, N.G. Vorodzeeva

Of particular interest is the Map of groundwater table (figure 4), the analysis of which shows that with the overall prevalence of levels of 50 - 75 % of security on the array as a whole, there is a significant diversity. Some very large areas of intensively irrigated land are characterized by relatively low security (25-50 =%), in other cases, on the contrary, the security is relatively high, up to 75-95% or more (figure 5, 6).

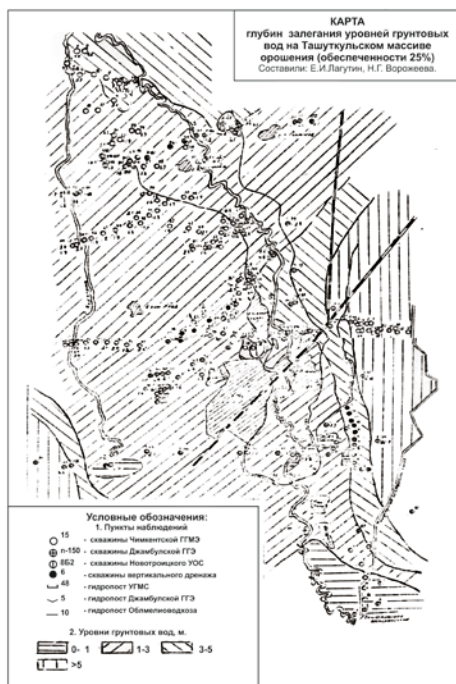

Figure 5 –  
Depth map of groundwater levels (25 % security).  
Made: E.I. Lagutin, N.G. Vorodzeeva

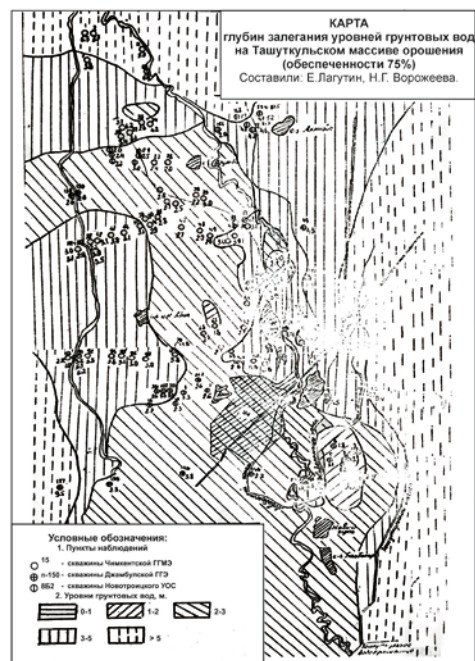

Figure 6 –  
Depth map of groundwater levels (75 % security).  
Made: E.I. Lagutin, N.G. Vorodzeeva

The importance to ameliorative hydrogeological evaluation to justify the design of drainage measures for the calculation of underground water have special hydrogeological maps obtained from the use of data on fluctuations of groundwater levels. These include, first of all, maps of the amount of evaporation (supply) of groundwater through the aeration zone, maps of "pulsation" of supply, maps of the rates of change of groundwater levels and maps of groundwater resources of different security.

In other words, the amount of feed per time interval ( $\Delta t$ ) is proportional to the change in groundwater levels over the same time interval.

Maps of evaporation and groundwater supply are obtained from the analysis of the General equation of groundwater supply.

$$\mu (\partial H/\partial t) = T (\partial^2 H/\partial x^2) + T (\partial^2 H/\partial y^2) + \partial W/\partial t \quad (1)$$

For point conditions, where the left side characterizes the change in moisture, the right - the distribution of pressure and power, the equation takes the form:

$$\mu \Delta N/\Delta t = \Delta H/\Delta t \quad (2)$$

In our calculations  $\Delta x = 1$  month., a  $\Delta H = NT + 1 - Ht$ , that is. changes in groundwater levels for 1 month were analyzed, then the data were recalculated in another series (m<sup>3</sup>/day per 1 ha of area), after which they were subjected to statistical processing. According to the results of statistical processing maps of groundwater evaporation were constructed (figure 7, 8).

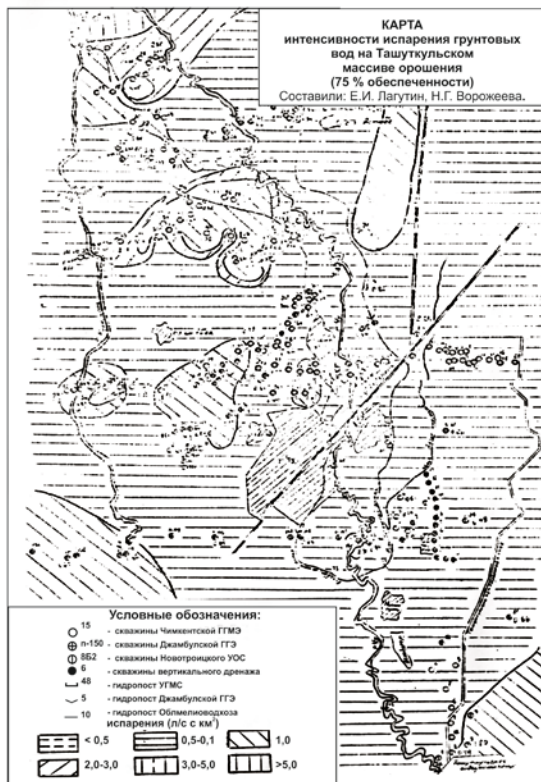

Figure 7 –

Map evaporation of groundwater Testcursor array of irrigation (75 % security). Made: E.I. Lagutin, N.G. Vorodgееva



Figure 8 –

Map of local modules groundwater Testconsole array of irrigation. Made: E.I. Lagutin, N.G. Vorodgееva

Analysis of such maps of different security for Tashutkul massif shows that in the year of 50 % security or in every second calendar month evaporation of groundwater occurs only in the Central part of the massif in small areas. On the overwhelming area of the massif there is the presence of groundwater supply in sizes up to 5 - 10 m<sup>3</sup>/day per 1 ha, which indicates the rise of groundwater levels at a rate of up to 0.01 - 0.1 m per month. The distribution of these values over the area of the array is very variegated. However, there is reason to believe that higher rates of level fluctuations are due to artificial reasons, i.e. intensively irrigated areas. Conditionally it is possible to allocate zones with speeds more than

0,1 m/month and less than 0,1 m/month and the first to carry to conditions of intensive irrigation and irrigation losses and the second – to conditions of weak irrigation losses. This situation, however, requires further study and is not the subject of this study. In periods 5% probability of the process, i.e. 1 time in 20 months the evaporation is negative, ie groundwater is fed in the sizes of 25 - 50 m<sup>3</sup>/day per 1 ha on the predominant areas of the Central part of the massif, 10 - 25 m<sup>3</sup>/day per 1 ha on the southern part, 50-75 m<sup>3</sup>/day per 1 ha - in the Northern and North-Eastern parts of the massif.

At 95 % of the provision of the process, that is, 1 time in 20 months, evaporation from the surface of groundwater occurs, and on the vast majority of the array (up to 90%) it is up to 25 m<sup>3</sup>/day per 1 ha. At 99% of the provision, i.e. 1 time in 100 months. (1 time in 7.5 years) the process is characterized by increased evaporation. While in the Central and southern parts it is 25-50 m<sup>3</sup>/day/ha, in the Northern part of the massif it is mainly 50 - 100 m<sup>3</sup>/day/ha and more than 100 (see figure 8) so of interest is the forecast Map of mathematical expectations of the values of evaporation (power) of groundwater. On this map, which contains essentially the average annual situation, separate zones are clearly distinguished, characterizing the tendency to the total consumption of groundwater and to reduce their levels in sufficiently large sizes (up to 0.1 m<sup>3</sup>/day/ha) and zones characterized by some average annual nutrition (also in sizes up to 0.1 m<sup>3</sup> /day/ha). The first are arranged in two horizontal bands at latitude G. Chu - S. Novotroitskoe in the Northern part of the massif, also in irrigated areas of removal cones in the foothills of HR. Khantau in the Eastern part of the massif (see figure 1B9.). In the rest of the territory there is a supply of groundwater. These are primarily irrigated areas in the head parts of the left-Bank and right-Bank main canals, in the Central part of the left Bank and in the Northern part of the district. The long-term trend towards rising groundwater levels in these areas requires active intervention to prevent salinization of soils and groundwater. The map of annual amplitudes of groundwater levels is made on the basis of statistical data processing of annual changes in the amplitude of the wells of the regime network. The most common annual amplitude in the range of 1-2 meters. On the Eastern edge of the massif with the approach to the middle parts of the removal cones amplitudes increase to 2-3 and more meters. Amplitudes on actively irrigated areas adjacent to the head of the left-Bank and right-Bank channels are also high.

Based on the Map of annual amplitudes of groundwater level fluctuations (figure 7) a Map of groundwater resource modules (figure 8). The module of groundwater reserves is the value of natural reserves formed per unit area. Following this definition, annual groundwater volumes per 1 ha per year were calculated in cubic metres. From the analysis of the map it follows that annually about 1.5-3.0 thousand m<sup>3</sup>/ha of ground water is formed on the overwhelming area of the massif. In some significant areas in the Eastern part of the array modules reach values of 3.0-4.5 thousand m<sup>3</sup>/ha. Even higher modules of 4.5-7.5 thousand m<sup>3</sup>/ ha are observed in the head part of the left-Bank and right-Bank channels on the areas of intensive irrigation

It should be noted that due to the rather good conditions of internal outflow in these areas, the groundwater reserves indicated on the Map are drained, mainly in the autumn-winter period and replenish the main drainage of the district - the Shu river.

**Conclusion.** The probabilistic hydrogeological maps of groundwater levels presented in this article and the special hydrogeological maps obtained on their basis described above can and should be widely used in the practice of design of reclamation measures in the development of the irrigated massif, including the calculations of groundwater withdrawals and vertical drainage. In meliorative-hydrogeological constructions, in particular, specific figures and areas of 5 and 25% of security are important, which corresponds to a minimum of 75 % and 95 % of security. This means that these minimum levels are possible once every 4 years (75 %) and once every 20 years (95 %). Can be used as input data in the design of reclamation drainage, including vertical, appropriate level of security. Security is 1 %, i.e. 1 every 100 years is very important in the design of foundations of critical structures, in order to assess their possible subsidence. Maps of 75 % and above (maximum) can be used in the design of groundwater intakes, and in accordance with the necessary design security, that is, the depth of groundwater levels should not be below 75 % of the security specified in 15 cases out of 20. In addition, such maps will be very useful in urban studies, predictive micro-seismic zoning, military engineering surveys, airfield construction, etc.

We recommend you to authorized organizations (GKZ) to produce the estimated acceptance of the protected categories of groundwater for deposits of underground water, drawing it on offer in this article a

probabilistic methodology for hydrogeological maps, which certainly enhance the objectivity and scientific conclusiveness protected final numbers and results.

**Gratitudes.** Deep gratitude to colleagues and companions in work in expeditions and further processing of initial monitoring information – G.G. Loshkov, I.Zh. Kadyrova, M.V. Luzina, N.G. Vorozheeva, E.A. Koytunenکو.

**Е. И. Лагутин<sup>1</sup>, В. А. Смоляр<sup>2</sup>, К. А. Кожобаев<sup>3</sup>, А. Г. Терехов<sup>4</sup>, М. Б. Едігенов<sup>5</sup>**

<sup>1</sup>Су мәселелері және экология институты, Тараз, Қазақстан;

<sup>2</sup>Гидрогеология және геоэкология институты, Алматы, Қазақстан;

<sup>3</sup>«Манас» қырғыз-түрік университеті, Бішкек, Қырғыз Республикасы;

<sup>4</sup>Ақпараттық және есептеу технологиялары институты,

Қазақстан Республикасы Орталық ғылыми-практикалық қоғамы, Алматы, Қазақстан;

<sup>5</sup>«Геоэкос» ғылыми-өндірістік фирмасы «ЖШС, Қостанай, Қазақстан

### **МАҢЫЗДЫ ГИДРОГЕОЛОГИЯЛЫҚ КАРТАЛАР**

**Аннотация.** Гидрогеологиялық карталар қазіргі уақытта өңірлік және жергілікті көріністегі гидрогеологиялық жағдайды бейнелеудің маңызды элементтерінің бірі болып табылады. Қолданыстағы нұсқаулықтарға сәйкес олар гидрогеологиялық түсірілім нәтижелері бойынша әр түрлі масштабтағы топографиялық, геологиялық және тектоникалық карталар негізінде жасалады және әдетте геологиялық-стратиграфиялық және тектоникалық түзілімдерге ұштастырылған су тұтқыш деңгейжиектер мен кешендердің таралу шекарасын және олардың жергілікті жердегі нақты көріністерін (көздер, құдықтар, бұрғылау ұңғымалары) көрсетеді. Жоғарыда сипатталған жалпы гидрогеологиялық карталардан басқа гидрогеологиялық процестің жекелеген жақтарын көрсететін арнайы гидрогеологиялық карталар мен тіліктер – жер асты сулары деңгейінің жату тереңдігінің карталары, сыйысымды жыныстардың сүзу қасиеттерінің карталары, су өткізгіштігінің және су тұтқыш қабаттардың деңгей өткізгіштігінің карталары, жер асты суларының химиялық құрамының карталары және басқалар жасалады.

Жоғарыда белгіленген барлық гидрогеологиялық карталар мен тіліктер статикалық және гидрогеологиялық процестің уақыт динамикасын көрсетпейді. Олар тек гидрогеологиялық-түсіру процесі барысында алынған геологиялық-тектоникалық негізде бірмезгілді далалық бастапқы гидрогеологиялық параметрлерді (жекелеген көздер мен гидрогеологиялық ұңғымалардың дебиті, жер асты суының химиялық құрамы мен физикалық сапасы, су тұтқыш қабаттардың кейбір гидрогеологиялық параметрлері) көрсетеді. Көрсетілген себептер бойынша олар гидрогеологиялық процестің одан әрі дамуын болжаудың сапасыз негізі бола алмайды. Мұндай бастапқы деректерге негізделген болжамды Гидрогеологиялық есептеулер, әдетте 15-30%-дан жоғары емес дәлдікпен және сенімділікпен ерекшеленбейді.

Осы бапта өз зерттеулерінің негізінде біз жаңа қағидаттарды ұсынамыз және гидрогеологиялық карталардың принципті басқа түрін құрудың нақты мысалдарын келтіреміз, ол уақыт бойынша гидрогеологиялық процестің динамикасын көрсетеді, болжамды Гидрогеологиялық есептеулер мен гидрогеологиялық-мелиоративтік болжамдардың дәлдігі мен дұрыстығын айтарлықтай арттырады (1-5%-ға дейін). Мұндай карталарды біз жер асты суларының режимі және олардың химиялық құрамы туралы көп жылдық мониторингтік мәліметтер базасында, Қазақстанның оңтүстігіне тән Ташуткул суару алқабының нақты материалында Ықтималдықтар теориясының математикалық әдістерін және кездейсоқ функциялар теориясын пайдалана отырып алдын ала өңделген. Нәтижесінде жер асты сулары деңгейінің, су тұтқыш қабаттың қуаттылығының, қамтамасыз етілу деңгейі әртүрлі Жер асты сулары ресурстарының (5, 25, 50 және т.б., %) жағдайының ықтимал гидрогеологиялық карталары алынды. Комплексте мұндай ықтимал гидрогеологиялық карталар суармалы алқаптардағы гидрогеологиялық-мелиоративтік жағдайды болжау үшін жеткілікті сапалы негіз болып табылады және жекелеген өңірлер мен әлеуметтік түзілімдердің жер асты суларының ресурстық әлеуетін болжау үшін сенімді негіз бола алады.

**Түйін сөздер:** Қазіргі гидрогеологиялық карталар, тіліктер. Карталардың статикалылығы. Қолданыстағы гидрогеологиялық есептер мен болжамдардың дәлдігі жеткіліксіз. Ықтимал гидрогеологиялық карталар. Мониторингтік бастапқы деректер. Деректерді ықтималдық өңдеу әдістері. Гидрогеологиялық есептеулер мен мелиоративтік-гидрогеологиялық болжамдардың едәуір жоғары дәлдігі.

Е. И. Лагутин<sup>1</sup>, В. А. Смоляр<sup>2</sup>, К. А. Кожобаев<sup>3</sup>, А. Г. Терехов<sup>4</sup>, М. Б. Едигенов<sup>5</sup>

<sup>1</sup>Институт водных проблем и экологии, Тараз, Казахстан;

<sup>2</sup>Институт гидрогеологии и геоэкологии, Алматы, Казахстан;

<sup>3</sup>Кыргызско-Турецкий университет "Манас", Бишкек, Кыргызская Республика;

<sup>4</sup>Институт информационных и вычислительных технологий цо МОН РК, Алматы, Казахстан;

<sup>5</sup>ТОО "Научно-производственная фирма Геоэкос", Костанай, Казахстан

## ВЕРОЯТНОСТНЫЕ ГИДРОГЕОЛОГИЧЕСКИЕ КАРТЫ

**Аннотация.** Гидрогеологические карты являются в настоящее время одним из важнейших элементов изображения гидрогеологической ситуации как в региональном, так и в локальном представлении. В соответствии с существующими инструкциями они составляются на основе топографических, геологических и тектонических карт различного масштаба по результатам гидрогеологической съемки и отражают границы распространения водоносных горизонтов и комплексов, приуроченных, как правило, к геолого-стратиграфическим и тектоническим образованиям, и их реальные проявления на местности (источники, колодцы, буровые скважины). Кроме описанных выше общих гидрогеологических карт, составляются специальные гидрогеологические карты и разрезы, отражающие отдельные стороны гидрогеологического процесса – карты глубин залегания уровня подземных вод, карты фильтрационных свойств вмещающих пород, карты водопроницаемости и увнепроницаемости водоносных горизонтов, карты химического состава подземных вод и другие.

Все обозначенные выше гидрогеологические карты и разрезы единомоментны и не отражают динамику гидрогеологического процесса во времени. Они лишь отражают на геолого-тектонической основе полученные в ходе гидрогеолого-съёмочного процесса полевые исходные гидрогеологические параметры (дебиты отдельных источников и гидрогеологических скважин, химический состав и физические качества подземной воды, некоторые гидрогеологические параметры водоносных горизонтов). По указанным причинам они не могут служить доброкачественной основой прогнозирования дальнейшего развития гидрогеологического процесса. Прогнозные гидрогеологические расчеты, основанные на таких исходных данных, не отличаются высокой точностью и достоверностью, обычно не выше 15-30% .

В настоящей статье на основании собственных исследований нами предлагаются новые принципы и приводятся конкретные примеры построения принципиально другого типа гидрогеологических карт, отражающих динамику гидрогеологического процесса во времени, существенно повышающие точность и достоверность прогнозных гидрогеологических расчетов и гидрогеолого-мелиоративных прогнозов (до 1-5%). Такие карты построены нами на базе многолетних мониторинговых данных о режиме подземных вод и их химическом составе, обработанных предварительно с использованием математических методов теории вероятностей и теории случайных функций на фактическом материале типичного для юга Казахстана Ташуккульского массива орошения. В результате были получены вероятностные гидрогеологические карты положения уровней грунтовых вод, мощностей водоносного горизонта, ресурсов подземных вод различной степени обеспеченности (5, 25, 50 и т.д. %). Были получены карты различных типов распределения вероятностей и прогнозирования гидрогеологического процесса. В комплексе такие вероятностные гидрогеологические карты служат достаточно доброкачественной основой для прогнозирования гидрогеолого-мелиоративной ситуации на орошаемых массивах и могут служить надежной основой для прогнозирования ресурсного потенциала подземных вод отдельных регионов и социальных образований.

**Ключевые слова:** *Существующие гидрогеологические карты, разрезы.* Статичность карт. Недостаточная точность основанных на них существующих гидрогеологических расчетов и прогнозов. *Вероятностные гидрогеологические карты.* Мониторинговые исходные данные. Вероятностная обработка.

### Information about authors:

Lagutin Evgeny Ivanovich, Director. Doctor of geological-mineralogical Sciences, academician of International Academy of Ecological Safety (St.-Petersburg, section of ecology), LLP "Institute of water problems and ecology" of the Republic of Kazakhstan, Taraz, Kazakhstan; eliktz4065@mail.ru; <https://orcid.org/0000-0002-7897-5620>

Smolyar Vladimir Alexandrovich, Chief specialist. Doctor of geological-mineralogical Sciences, academician of International Academy of Ecological Safety (St.Petersburg, section of ecology), LLP "Kazecoproject" Republic of Kazakhstan, Almaty, Kazakhstan; v\_smolyar@mail.ru. <https://orcid.org/0000-0003-4790-339X>

Kojobaev Kanatbek Asekovich, Doctor of technical Sciences, Professor, Academician of Engineering Academy of KR, Kyrgyz-Turkish Manas University, Bishkek, Kyrgyz Republic; kojkanik@gmail.com; kanatbek.kojobaev@manas.edu.kg; <https://orcid.org/0000-0001-6719-5015>

Terekhov Alexey Gennadievich, leading researcher, Candidate of technical Sciences, RSE "Kazhydromet" Republic of Kazakhstan, Almaty, Kazakhstan; aterekhov1@yandex.ru; <https://orcid.org/0000-0003-3209-1333>

Edigenov Michael Bekkyzhievich, Director. Candidate of geological-mineralogical Sciences, LLP "Scientific-production firm Geokos" Republic of Kazakhstan, Kostanai, Kazakhstan; edigenov@mail.ru; <https://orcid.org/0000-0002-2915-7023>

#### REFERENCES

- [1] Averyanov S.F. (1978) Fight against salinization of irrigated lands. M., "Kolos" (in Russ.).
- [2] Akhmedsafin U.M. (1982) et al. Formation and groundwater resources of southern Kazakhstan. Alma-ATA, "Science". 920 p. (in Russ.).
- [3] Baron B. A., Serov V. N. (1971) Methodological recommendations on the prediction mode, the level of groundwater irrigated areas to subaerial deltas. M., "VSEGINGEO". 68 p. (in Russ.).
- [4] The Bindeman N.N., Yazvin L.S. (1970). Estimation of operational stocks of underground waters M., "Nedra" (in Russ.).
- [5] Bogomolov Y.G. Zhabin S.V., Khachatryan V. H. (1980). The Change of the hydrogeological conditions under the impact of reclamation. M., "Science" (in Russ.).
- [6] Bochever F.M., Garmonov M.V., Lebedev D.V. (1969). the basis of the hydrogeological calculations. M. "Nedra" (in Russ.).
- [7] Gulaev A.J. Panasenko I.M., Lagutin E.I. (1979). Ecological-economic assessment of integrated development of water resources of closed basins. Theses of reports at the IV all-Union interuniversity scientific conference "Economic problems of improving the efficiency of capital investments in land reclamation in the light of the decisions of the July (1978) Plenum of the Central Committee." Tashkent (in Russ.).
- [8] Zapariy M.P. (1975). Assessment of prospects of the territory of the USSR in the use of groundwater for irrigation. In The Security Council. "Questions of meliorative hydrogeology". Issue 100. M. "Nedra" (in Russ.).
- [9] Kamenskii G.N. Tolstikhina M.M., Tolstikhin N.I. (1960). Hydrogeology of the USSR. M., "Gosgeoltekhizdat" (in Russ.).
- [10] Katz D.M., Bogomolov Yu.G., Zhelobov A.A. (1976). And others the Role of groundwater in the development of reclamation and drainage in the USSR. In the book. Problems of hydrogeology of arid regions. International geological Congress, XXV session. Reports of Soviet geologists. M. "Science" (in Russ.).
- [11] Lagutin E.I. (2019). Forecast of the meliorative-hydrogeological situation on the irrigated massif using the Monte Carlo method. Geology and subsoil protection N 4 (73). P. 45-52 (in Russ.).
- [12] Lagutin E.I. (2019). Water resources of Central Asia at the present stage (problems and prospects) Science, new technologies and innovations of Kyrgyzstan. N 4. P. 230-232 (in Russ.).
- [13] Lagutin E.I., Smaller V.A., Kozhobayev K.A., Tereshov A.G., Edigenov M.B., Atykenova E.E. (2019). Use of mathematical methods in genetic research of underground hydrosphere (on the example of Tien-Shan) Science, new technologies and innovations of Kyrgyzstan. N 4. P. 233-239 (in Russ.).
- [14] Lagutin E.I. (2018). Modelling of geohydrology of underground runoff of Central Asia 's landlocked orogens. Science, new technologies and innovations of Kyrgyzstan. N 3. P. 141-145 (in Russ.).
- [15] Lagutin E.I., Mambetaliyeva Sh.M. Hydrogeochemical zones of the hydraulic sphere of Kyrgyzstan Science, new technologies and innovations of Kyrgyzstan. 2018. N 3. P. 192-196 (in Russ.).
- [16] Usupayev Sh.E., Valiev Sh.F., Lagutin E.I., Sadybakasov I.S., Atykenova E.E., Sharifov G.V., Dudashvili A.S., Andamov R.S. (2017). The "xv - ignon" methodology in geoid theory and practice. Science and Innovation. N 1. P. 184-192 (in Russ.).
- [17] Lagutin E.I., Usupayev S.E. (2014). Management of georisk grazing water intakes of underground runoff on the example of Central Kazakhstan News of the Kyrgyz State Technical University named after I. Razzakov. N 33. P. 409-413 (in Russ.).
- [18] Lagutin E.I., Usupayev S.E. (2014). Anthropogenic geohazards and georics in Kazakhstan. News of the Kyrgyz State Technical University named after I. Razzakov. N 33. P. 422-425 (in Russ.).
- [19] Usupayev S.E., Edigenov M.B., Lagutin E.I. (2014). Georisk hydrospheres of land in sub-parts of Central Asia. Journal of the Institute of Seismology of the National Academy of Sciences of the Kyrgyz Republic. N 1 (3). P. 121-128. (in Russ.).
- [20] Lagutin E.I. (2011). Exploration and calculation of groundwater for irrigation; Mezhdunar. Foundation of Akad K. I. Satpayev, Ministry of Education of Republic. Kazakhstan, U. M. Ahmedsafin in hydrogeology and geoecology. Taraz. Prod. Format-plus. 239 p. (in Russ.).
- [21] Lagutin E.I. (2010). Chemical composition of groundwater Tian Shania Northwest part, Kyrgyzstan / Mezhdunar. S. I. Satpayev Foundation of Hydrogeology and Geoecology named after W. M. Ahmedsafin. Taraz. Prod. Format-plus. 310 p. (in Russ.).
- [22] Lagutin E.I., Mambetaliyeva Sh.M. (2009). Underground reservoirs on pastures of Central Kazakhstan (exploration, design, construction and operation)/; In-t of hydrogeology and geoecology named after W. M. Ahmedsafin. Taraz. Prod. Format-plus. 179 p. (in Russ.).
- [23] Lagutin E.I., Sychev K.I., Fomenko V.I., Khordikainen M.A. (1979). Creation of artificial groundwater resources during grazing Forestry and forestry. N 1. 55 p. (in Russ.).
- [24] Lagutin E.I., (2010). "Rational use of low-power aquifers of the exogenous fracture zone for restoration and watering of pastures in Central Kazakhstan". Izvestiya NAS RK. A series of geological. N 5. P. 50-58 (in Russ.).
- [25] Lebedev A.V. (1957). Forecast of changes in groundwater level in irrigated areas. M., "Gosgeoltekhizdat". 187 p. (in Russ.).

- [26] Methodological guidance on hydrogeological and engineering-geological studies for reclamation construction on irrigated lands. Issue 3. M. 1972 (in Russ.).
- [27] Methodical guidance on the choice of the type of water intake facilities for vertical drainage on irrigated lands. "Soyuzvodproekt". Approved. Soyuzvodproekt from 24.12.75 (in Russ.).
- [28] Methodological guidelines for the calculation of groundwater intakes for irrigation. "Soyuzvodproekt". Approved. Minvudkhoz. Of the USSR from 10.11.75 (in Russ.).
- [29] Guidelines for the production of hydrogeological survey at a scale of 1:50000 and 1:200000. M., "Gosgeoltekhizdat" 1962 (in Russ.).
- [30] Guidelines for the production of hydrogeological survey at a scale of 1:1000000 and 1:500000. and 1:200000-1:100000. M., "Gosgeoltekhizdat" 1962 (in Russ.).
- [31] Methodological guidance on the justification and integration of research methods in hydrogeological and engineering-geological survey for land reclamation. Issue. IV. M., "Nedra" 1979 (in Russ.).
- [32] Mirzaev S.S., Valiev H.V. (1977). Exploration and evaluation of groundwater reserves for irrigation. Tashkent. "Fan" (in Russ.).
- [33] Mirzaev S.Sh. Plotnikov N. (1977). So. Hydrogeological forecasts and groundwater use for irrigation. In the collection "Materials of the interdepartmental meeting on forecasting of hydrogeological, engineering-geological and soil-reclamation conditions". Issue. M. (in Russ.).
- [34] Pashkovsky I.S. (1973). Methods of determination of infiltration power according to the calculations of moisture transfer in the aeration Zone. Moscow state University Publishing house (in Russ.).
- [35] Reshetkina N.M., Yakubov R.A., (1978). Vertical drainage. Publishing house of UzSSR (in Russ.).
- [36] Guidelines for the design mode of operation of vertical drainage systems for the conditions of Central Asia (VTR-P-II-76). Composed of SANIIRI. Minvudkhoz of the USSR from 08.12.76 (in Russ.).
- [37] Fahrenholz E.D., Kolyada M.N. (1969). Experience of application of methods of mathematical statistics to study the laws of distribution of hydrogeological parameters. In the book.: Evaluation of groundwater resources. M., "Nedra". Vol. 171 (in Russ.).
- [38] Hald. A. (1965). Mathematical statistics with technical applications. "Publishing house of foreign literature". 326 p. (in Russ.).
- [39] Kharchenko S. I. (1975). Hydrogeology of irrigated lands. L., "Gidrometeoizdat".
- [40] Yazvin L.S. (1972). The Reliability of hydrogeological forecasts in the assessment of operational reserves of groundwater. M., "Nedra" 1972 (in Russ.).
- [41] Lagutin E.I. (2019). Geohydrodynamic systems of the continental sub-part of the planet Earth as the basis of hydrogeological stratification (On the example of Central Asia). American Sciences Journal. N 32 / (2019). Vol.2. P. 4-13. (in Eng).
- [42] Lagutin E.I. (2019). Modern design solutions for watering summer pastures using groundwater (Central Kazakhstan). Eurasian Union of scientists (ECU). Monthly scientific journal. N 12 (69)/2019). Vol.4. P. 11-17. ISSN 2411-4467.(Print). <https://doi.org/10.31618/2019.4-69>. (in Eng).
- [43] Mukhamedzhanov M.A., Sagin Jay, Kazanbaeva L. M., Nurgazieva A.A. (2019). Challenging issues of fresh water within the territory of East Kazakhstan and adjacent areas of Central Kazakhstan// Bulletin of national academy of sciences of the Republic of Kazakhstan. 2019. Vol. 2, N 434. P. 15-20. ISSN 2518-170X (Online), ISSN 2224-5278 (Print). <https://doi.org/10.32014/2019.2518-170X.33> (in Eng).

**NEWS**

OF THE NATIONAL ACADEMY OF SCIENCES OF THE REPUBLIC OF KAZAKHSTAN

**SERIES OF GEOLOGY AND TECHNICAL SCIENCES**

ISSN 2224-5278

Volume 2, Number 440 (2020), 114 – 122

<https://doi.org/10.32014/2020.2518-170X.38>

UDC 550.837.82

**Y. Z. Murtazin<sup>1</sup>, O. L. Miroshnichenko<sup>1</sup>, L. Y. Trushel<sup>1</sup>, V. A. Smolyar<sup>2</sup>, V. M. Mirilas<sup>3</sup>**

<sup>1</sup>Satbayev University, Ahmetsafin Institute of Hydrogeology  
and Environmental Geoscience, Almaty, Kazakhstan;

<sup>2</sup>"Kazecoproekt", Almaty, Kazakhstan;

<sup>3</sup>Ariel University, Israel.

E-mail: ye\_murtazin@list.ru; o\_mirosh@mail.ru; lydmila\_y\_t@mail.ru,  
smolyar@mail.ru, vladimirmster@gmail.com

## **CREATION OF COMPUTER MODELS OF THE MAPS OF GROUNDWATER AVAILABILITY IN KAZAKHSTAN**

**Abstract.** The impact of anthropogenic load and climate change on groundwater requires a comprehensive study of the underground hydrosphere. The large volume of various data used for solving this problem requires development of specialized information systems.

The geoinformation and analytical system "Resources and reserves of groundwater in the Republic of Kazakhstan" developed by the Institute of Hydrogeology and Geoecology includes computer models of the maps of groundwater resources availability in Kazakhstan. They serve as a basis for development of specialized hydrogeologic maps.

Computer models of the maps are created using the geographic information system and included in the graphic database. They are built in the same coordinate system, with the same scale and using a single cartographic basis. The values of resources are calculated for various territorial objects (hydrogeological basins, water management basins, administrative districts) and included in the semantic database. Graphic objects displayed on a map and tables of the semantic database may be linked up after introduction of an identifier field. The maps of groundwater resources availability are built within the boundaries of administrative regions and contain areas singled out based on operational reserves availability and forecast resources for various purposes.

Attributive data are presented in the maps in the form of diagrams of resources distribution according to various criteria (mineralization, purpose, category etc.).

The geoinformation and analytical system of resources and reserves of groundwater in Kazakhstan is also supplemented with computer models of the maps of natural reserves, forecast resources, operational reserves of groundwater in Kazakhstan, as well as with computer models of the maps of groundwater resources availability in the Republic of Kazakhstan. It is an open information system that will be supplemented with map options developed based on various methods of groundwater resources calculation.

**Key words:** groundwater, information systems, groundwater resources.

Climate change and significant anthropogenic impact have a considerable influence on the distribution, formation and conditions of groundwater occurrence. Therefore, much attention is currently being paid to the study of the processes taking place in the underground hydrosphere. An information system may provide a comprehensive picture of groundwater interaction with other environmental objects.

One of examples is the Global Groundwater Information System created by the IGRAC [1]. The AquaBase geocological monitoring system is designed for analysis of groundwater resources data [2]. The US National Groundwater Information System contains materials about groundwater resources and methods for its assessment [3]. The groundwater data are included in the Atlas of Groundwater-Dependent Ecosystems of Australia [4]. A dedicated information system was designed to assess and comprehensively manage the groundwater resources of China [5]. A thematic map of the groundwater potential of West Bengal in India was prepared using the ERDAS Imagine and ArcGIS programs [6]. A cartographic

information system and modeling of geo-filtration processes were used to create a thematic map for assessing soil salinity hazard in the Jezre’el Valley in Israel and information support for planning an effective drainage system to prevent soil salinization of irrigated lands [7]. A detailed overview of the information systems including groundwater data is presented in our article [8]. The geoinformation and analytical system “Resources and reserves of groundwater in the Republic of Kazakhstan” developed by the Institute of Hydrogeology and Geoecology includes document databases, bases of graphic and semantic data and bases of mathematical models [9,10]. The system also contains such elements as computer models of the maps of groundwater resources and groundwater availability in Kazakhstan [11].

Depending on the methods used for calculating hydrogeological parameters there are many options for building maps of groundwater resources and groundwater availability [12]. By computer models of the maps in the geoinformation and analytical system we mean the maps built in the same coordinate system, with the same scale, using a single cartographic basis and containing areal objects the attribute information of which should be taken from the data on groundwater resources and reserves retrieved from the tables of the semantic database. Maps are built using the geographic information system. It should be noted that groundwater resources and reserves can be systematized according to various criteria [13]. The structure of the presented information system reflects one of the options for their division into classes (figure 1).

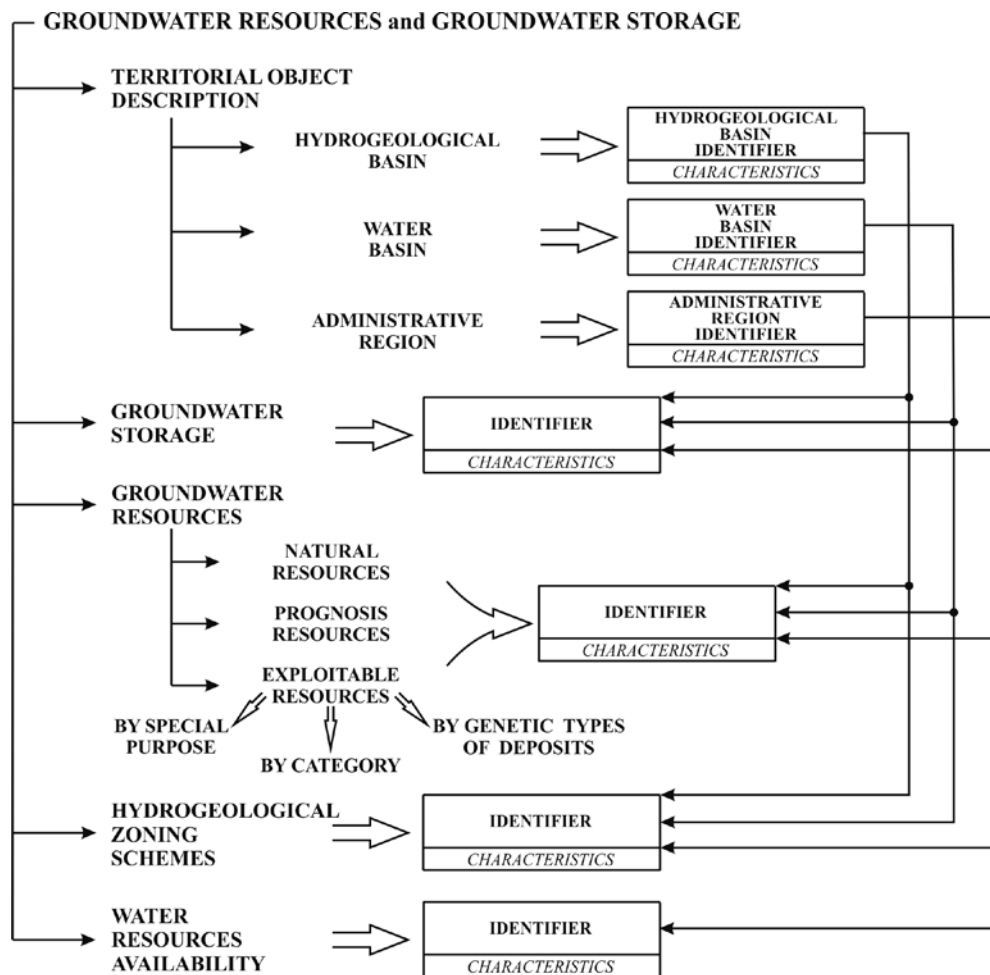

Figure 1 – Information structure of the “Groundwater Resources and Reserves” block

Groundwater resources are calculated for various territorial objects: hydrogeological basins, water management basins, administrative districts. Traditionally, we distinguish natural, forecast and operational groundwater resources. The maps are built according to this classification [14]. The maps of groundwater resources availability are built within the boundaries of administrative regions.

The maps show the diagrams reflecting the values of explored operational reserves and forecast groundwater resources differentiated in terms of mineralization, intended use and others. It should be

emphasized that the basis for computer models of the maps «Resources of groundwater in Kazakhstan» и «Groundwater availability in Kazakhstan» is formed by the data from the tables of the semantic database.

Computer models of the maps of natural groundwater reserves distribution across hydrogeological massifs and basins of the plain territory of the Republic of Kazakhstan. According to the completed hydrogeological zoning based on the geological and structural principle, hydrogeological structures are divided into two main categories of structures - hydrogeological massifs and hydrogeological basins which are represented as the main units of hydrogeological zoning of the first order [15,16]. Natural groundwater reserves distribution across hydrogeological massifs and basins of the plain territory of the Republic of Kazakhstan is reflected on a corresponding map of the information system (figure 2).

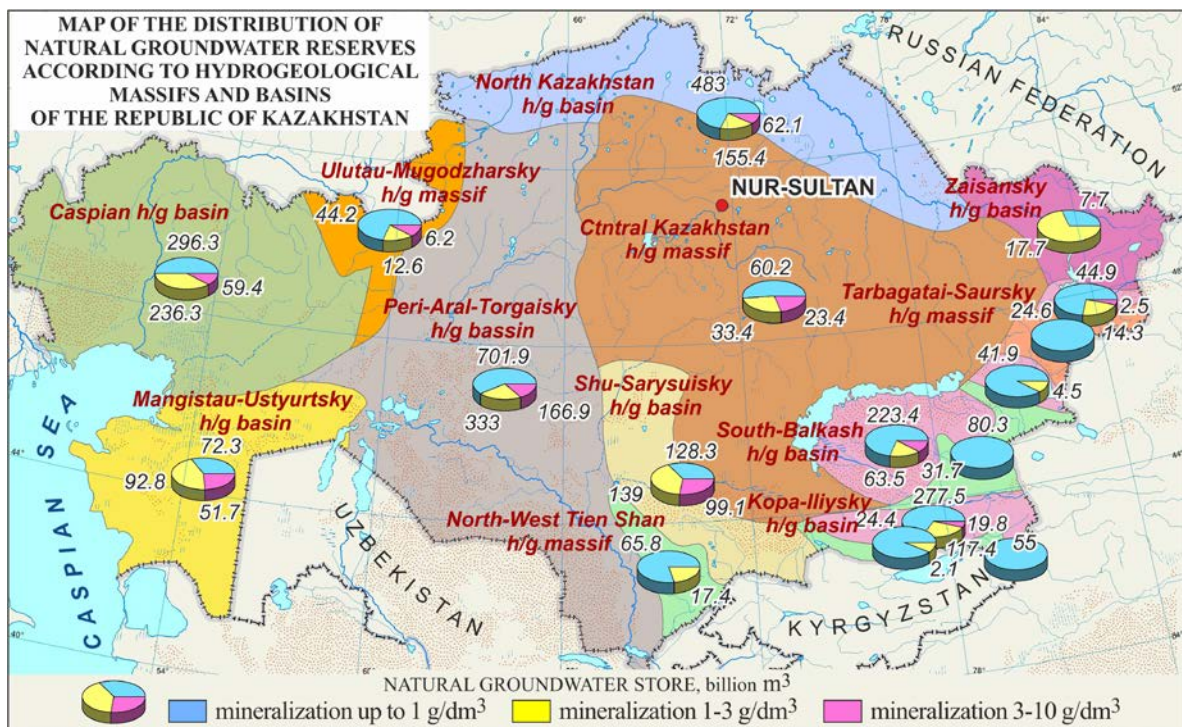

Figure 2 – Map of natural groundwater reserves distribution across hydrogeological massifs and basins of the plain territory of the Republic of Kazakhstan

Computer models of the maps “Forecast Groundwater Resources in Kazakhstan”. The maps were designed based on the classification of groundwater by its mineralization. The maps were built for the zones associated with water management basins, hydrogeological basins and administrative regions. To ensure a better visual presentation of the data the maps include diagrams of forecast resources distribution by mineralization across certain selected territories. A water management basin is a river basin within its natural boundaries or a part thereof characterized by uniform natural conditions [15, 16]. There are 8 water basins in the territory of Kazakhstan. The largest volume of forecast fresh groundwater resources is concentrated within the Balkhash-Alakol Water Basin and constitutes about 37% of the total volume of forecast groundwater resources [14,17]. The map of distribution of forecast groundwater resources of Kazakhstan across water management basins with consideration of its mineralization is introduced in the system.

The territory of the Republic of Kazakhstan consists of 14 administrative regions. Uneven distribution of groundwater resources in the republic is associated with the peculiarities of geological structure, hydrogeological and climatic conditions. The map of distribution of forecast groundwater resources across administrative regions of the Republic of Kazakhstan with consideration of their mineralization was introduced in the information system [14,18].

Classification of hydrogeological groundwater basins was carried out based on two main criteria: form of bodies of groundwater accumulation (or types of accumulation) and dynamics (groundwater head and direction of groundwater runoff). In [19] hydrogeological zoning of the territory of Kazakhstan was

carried out according to the following system of subordinate taxonomic units of regional zoning: region, basins of first and second order acting as separate hydrogeological structures with the same or similar conditions for formation of both free and pressure groundwater.

The presented principles of hydrogeological zoning in Kazakhstan allowed identification of the following seven hydrogeological regions. The regions, in their turn, are divided into basins of the first order which are complex groundwater basins. In Kazakhstan, based on the principles of hydrogeological zoning, there are 21 basins of the first order. Two groups of hydrogeological structures of the second order can be distinguished based on the conditions of distribution and circulation within these systems. The system is also supplemented with maps of forecast groundwater resources distribution with consideration of their mineralization across hydrogeological regions, structures of the first and second orders of Kazakhstan [14].

*Computer models of the maps “Operational Groundwater Resources in Kazakhstan”.* Operational groundwater reserves are estimated for administrative regions, water management basins and hydrogeological structures (basins). Each type of territorial objects has its own models of the maps of operational groundwater reserves distribution by intended use, genetic types of deposits and categories. The maps of operational groundwater reserves distribution are built for the water management basins. The majority of groundwater deposits were explored for utility and drinking water supply. The information system was provided with the maps of operational groundwater reserves distribution by intended use within the territory of the water management basins of the Republic of Kazakhstan [14,20].

According to the existing classification and based on a set of geological and hydrogeological factors, groundwater deposits of Kazakhstan are divided into five genetic types. Almost a quarter of groundwater deposits are associated with river valleys. Total operational reserves constitute 21 % of the explored reserves of Kazakhstan. Most of operational groundwater reserves are concentrated in alluvial cones of aggradational benches and intermountain troughs of South and South-East Kazakhstan. It is shown on the map of operational groundwater reserves distribution by genetic types of deposits within the territory of the water management basins of the Republic of Kazakhstan which was introduced into the information system.

Depending on a degree of exploration the operative reserves can be divided into four categories – A, B, C<sub>1</sub> and C<sub>2</sub>. The largest operational groundwater reserves are concentrated in the Balkash-Alakol water basin. The information system was provided with the map of operational groundwater reserves distribution with consideration of their categorization within the territory of the water management basins of the Republic of Kazakhstan [14].

The maps of operational groundwater reserves distribution are built for the administrative regions of the Republic of Kazakhstan. Their estimation was carried out according to their intended use, genetic types of deposits and categories. The largest operational groundwater reserves (16721.778 thousand m<sup>3</sup>/day) are typical for the Almaty Region. These data are presented in the information system in the form of the map of operational groundwater reserves distribution by intended use.

The largest explored operational reserves are concentrated in the Almaty Region in alluvial cones of aggradational benches and intermountain troughs (14550,327 thousand m<sup>3</sup>/day). The map of operational groundwater reserves distribution by genetic types of deposits with a breakdown into administrative regions of the Republic of Kazakhstan was introduced into the information system [14]. The maps of operational groundwater reserves distribution are built by hydrogeological structures of the Republic of Kazakhstan. Maps of operational groundwater reserves distribution were introduced into the information system with consideration of the intended purpose and categorization by hydrogeological structures (regions) of the Republic of Kazakhstan; maps of operational groundwater reserves distribution across hydrogeological basins of the first and second orders with consideration of the intended purpose and categorization of the Republic of Kazakhstan.

*Computer models of the maps of groundwater resources availability in the Republic of Kazakhstan* When saying “the availability of utility and drinking groundwater to the population” we mean as a possible degree of satisfaction of current and future needs of the population in drinking water through forecast resources and explored groundwater operational reserves [17]. The map of availability of forecast resources and explored groundwater operational reserves uses bar diagrams for showing the ratio of forecast resources, operational reserves and groundwater extraction values (figure 3). The map of groundwater resources availability [20] was also introduced in the information system. Along with circular

diagrams which indicate the percentage of values of forecast groundwater resources with different mineralization and groundwater operational reserves of various categories, it also shows the data on areas, population, operational groundwater reserves for utility and drinking purposes per capita across all administrative regions. The territory of Kazakhstan is fully provided with forecast and proven groundwater reserves of different intended use, although its uneven distribution causes shortage of fresh groundwater in a number of localities.

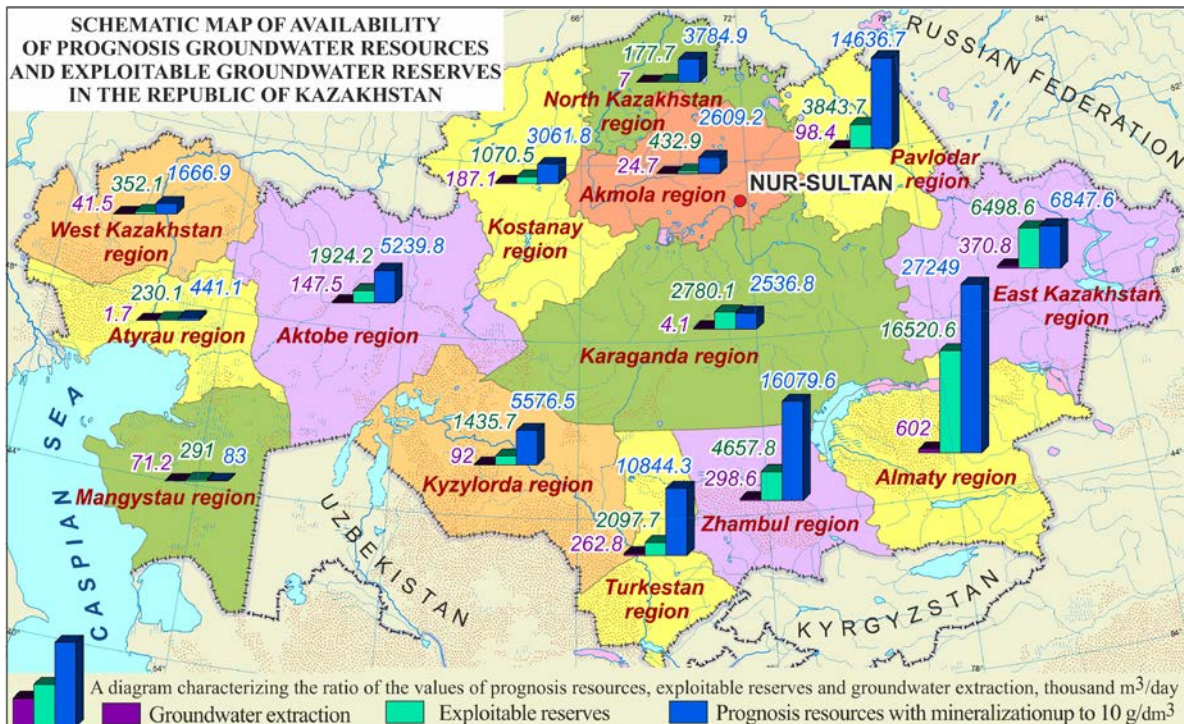

Figure 3 – Map of availability of forecast resources and explored groundwater operational reserves in the Republic of Kazakhstan

When creating computer models of the maps the semantic database was completed using Excel [21] whereas the graphic database – using ArcGIS and MapInfo applications [22,23].

Therefore, the geoinformation and analytical system of resources and reserves of groundwater in Kazakhstan is now supplemented with computer models of the maps of natural reserves, forecast resources, operational reserves of groundwater in Kazakhstan, as well as with computer models of the maps of groundwater resources availability in the Republic of Kazakhstan.

The created models of the maps can be used by regional and republican administrative structures for forecasting the development of regional economies, planning economic activities and initiating the environmental measures.

Е. Ж. Муртазин<sup>1</sup>, О. Л. Мирошниченко<sup>1</sup>, Л. Ю. Трушель<sup>1</sup>, В. А. Смоляр<sup>2</sup>, В. М. Мирлас<sup>3</sup>

<sup>1</sup>Satbayev University, Ахмедсафин атындағы гидрогеология және геоэкология институты, Алматы, Қазақстан;

<sup>2</sup>«Казэкопроект», Алматы, Қазақстан;

<sup>3</sup>Ариэль университеті, Израиль

### ҚАЗАҚСТАННЫҢ ЖЕРАСТЫ СУЛАРЫМЕН ҚАМТАМАСЫЗ ЕТУ КАРТАСЫНЫҢ КОМПЬЮТЕРЛІК ПІШІНДЕРІН ҚҰРАСТЫРУ

**Аннотация.** Жер асты суларына антропогендік жүктемелердің әсері және климаттың өзгеруі жер асты гидроферасын кешенді зерттеуді талап етеді. Осы міндетті шешу үшін тартылатын әр текті деректердің үлкен көлемі мамандандырылған ақпараттық жүйелерді құруды талап етеді.

Гидрогеология және геоэкология институтында құрылған «Қазақстан Республикасының жер асты суларының ресурстары мен қорлары» геоақпараттық-аналитикалық жүйесі жер асты суларының ресурстары мен Қазақстанның жер асты суларымен қамтамасыз ету карталарының компьютерлік макеттерін қамтиды. Олар мамандандырылған гидрогеологиялық карталарды жасау үшін негіз болып табылады.

Карталар гидрогеологиялық параметрлерді есептеудің қолданылатын әдістемелеріне байланысты құрылады және есептеу нәтижелерін көрсететін мазмұндық ақпаратпен қатар осы есептер негізінде жүргізілген қосымша мәліметтерді қамтиды.

Ақпараттық жүйеге дәстүрлі гидрогеологиялық көріністерді көрсететін жіктемеге сәйкес карталардың макеттері енгізілді. Жер асты суларының ресурстары мен қорлары әртүрлі белгілері бойынша жүйеленуі мүмкін. Ұсынылған ақпараттық жүйенің құрылымы оларды кластарға бөлу нұсқаларының бірін көрсетеді.

Карталардың компьютерлік макеттері геоақпараттық жүйе құралдарымен құрылады және графикалық деректер базасына кіреді. Олар бір координат жүйесінде, бір масштабта, бірыңғай картографиялық негізде салынған. Ресурстардың шамасы әртүрлі аумақтық объектілер (гидрогеологиялық бассейндер, су шаруашылығы бассейндері, әкімшілік аудандар) шеңберінде есептелген және семантикалық деректер базасында ұсталады. Картада бейнеленетін графикалық объектілердің және семантикалық деректер базасы кестелерінің байланысы идентификатор-өрісін енгізу жолымен жүзеге асырылады. Жер асты суларымен қамтамасыз ету карталары әкімшілік облыстардың шекарасында салынған және пайдалану қорларымен және әртүрлі мақсаттар үшін болжамды ресурстармен қамтамасыз етілуі бойынша бөлінген аймақтарды қамтиды.

Атрибуттық деректер карталарда әртүрлі белгілер (минералдану, нысаналы мақсаты, санаты және т.б.) бойынша ресурстарды бөлу диаграммалары түрінде ұсынылған.

Қазақстанның жер асты суларының ресурстары мен қорларының геоақпараттық-талдамалық жүйесі Қазақстанның жер асты суларының табиғи қорлары, болжамды ресурстары, пайдалану қорлары карталарының компьютерлік макеттерімен, сондай-ақ Қазақстан Республикасының жер асты суларымен қамтамасыз ету карталарының компьютерлік макеттерімен толықтырылған.

Табиғи қорларды бөлу картасы гидрогеологиялық алаптар мен жазық аумақтардың бассейндері шегінде қалыптасқан. Болжамды ресурстар карталары жер асты суларының әр түрлі аудандар шеңберінде минералдану бойынша бөлінуін көрсетеді. Тұщы жер асты суларының негізгі ресурстары (59,3%) оңтүстік өңірде, Алматы, Жамбыл, Қызылорда және Түркістан облыстарында шоғырланған, орталық, солтүстік және батыс өңірлер болжамды ресурстардың төмен шамасымен ерекшеленеді. Жер асты суларының болжамды пайдалану ресурстары I және II реттік гидрогеологиялық бассейндер бойынша бағаланды.

Аумақтық объектілердің әрбір түрі үшін пайдалану қорларын нысаналы мақсаты, кен орындарының генетикалық типтері, санаттары бойынша бөлу карталарының макеттері салынған. Жер асты сулары кен орындарының негізгі саны шаруашылық-ауыз сумен жабдықтау үшін, ал кейбір жағдайларда – шаруашылық-ауыз сумен жабдықтау үшін және басқа да мақсаттар үшін – жерді суландыру немесе техникалық сумен жабдықтау үшін барланған. Жер асты суларының пайдаланылатын қорларының негізгі көлемі Оңтүстік және Оңтүстік-Шығыс Қазақстанның тау бөктеріндегі шлейфтер мен тауаралық ойпаттарды шығару конустарында шоғырланған. Жер асты суларының ең көп пайдалану қоры (16721,778 мың м<sup>3</sup>/тәул) Алматы облысына, ал ең азы Солтүстік Қазақстан облысына тән.

Жер асты суларымен қамтамасыз ету карталары болжамды ресурстар мен жер асты суларының барланған пайдалану қорлары есебінен халықтың ауыз суға ағымдағы және перспективалық қажеттіліктерін қанағаттандыру дәрежесін көрсетеді. Карталар минералдануы әртүрлі жер асты суларының болжамды ресурстары шамаларының, әртүрлі санаттағы жер асты суларының пайдаланылатын қорларының, жер асты суларын алудың арақатынасының диаграммаларын қамтиды. Қазақстан аумағының әртүрлі нысаналы мақсаттағы жер асты суларының болжамды және бекітілген қорларымен қамтамасыз етілуі туралы қорытынды жасалуы мүмкін, бірақ олардың таралуының біркелкі болмауы бірқатар аудандарда тұщы жер асты суларының тапшылығын тудырады.

Салынған карталардың макеттерін облыс экономикасының дамуын болжау, шаруашылық қызметті жоспарлау, экологиялық іс-шараларды әзірлеу процесінде облыстық және республикалық әкімшілік құрылымдар пайдалана алады.

Ақпараттық жүйе ашық болып табылады және жер асты сулары ресурстарын есептеудің әртүрлі әдістемелерінің негізінде салынған карталардың нұсқаларымен толықтырылатын болады.

**Түйін сөздер:** жер асты сулары, ақпараттық жүйелер, жер асты суларының ресурстары.

Е. Ж. Муртазин<sup>1</sup>, О. Л. Мирошниченко<sup>1</sup>, Л. Ю. Трушель<sup>1</sup>, В. А. Смоляр<sup>2</sup>, В. М. Мирлас<sup>3</sup>

<sup>1</sup>Satbayev University, Институт гидрогеологии и геоэкологии им. Ахмедсафина, Алматы, Казахстан;

<sup>2</sup>«Казэкопроект», Алматы, Казахстан;

<sup>3</sup>Университет Ариэль, Израиль

## СОЗДАНИЕ КОМПЬЮТЕРНЫХ МАКЕТОВ КАРТ ОБЕСПЕЧЕННОСТИ КАЗАХСТАНА ПОДЗЕМНЫМИ ВОДАМИ

**Аннотация.** Воздействие антропогенных нагрузок и изменения климата на подземные воды требует комплексного изучения подземной гидросферы. Привлекательный для решения этой задачи большой объем разнородных данных требует создания специализированных информационных систем.

Создаваемая в Институте гидрогеологии и геоэкологии геоинформационно-аналитическая система «Ресурсы и запасы подземных вод Республики Казахстан» включает компьютерные макеты карт ресурсов подземных вод и обеспеченности подземными водами Казахстана. Они являются основой для создания специализированных гидрогеологических карт.

Карты строятся в зависимости от используемых методик расчетов гидрогеологических параметров и наряду с содержательной информацией, отражающей результаты вычислений, включают дополнительные сведения, на основании которых эти расчеты проводились.

В информационную систему внесены макеты карт в соответствии с классификацией, отражающей традиционные гидрогеологические представления. Ресурсы и запасы подземных вод могут быть систематизированы по разным признакам. Структура представленной информационной системы отражает один из вариантов их разделения на классы.

Компьютерные макеты карт строятся средствами геоинформационной системы и входят в базу графических данных. Они построены в одной системе координат, одном масштабе, на единой картографической основе. Величины ресурсов рассчитаны в рамках различных территориальных объектов (гидрогеологических бассейнов, водохозяйственных бассейнов, административных районов) и содержатся в базе семантических данных. Связь отображаемых на карте графических объектов и таблиц базы семантических данных осуществляется путем введения поля-идентификатора. Карты обеспеченности подземными водами построены в границах административных областей и содержат регионы, выделенные по обеспеченности эксплуатационными запасами и прогнозными ресурсами для различных целей.

Атрибутивные данные представлены на картах в виде диаграмм распределения ресурсов по различным признакам (минерализации, целевому назначению, категории и др.).

Геоинформационно-аналитическая система ресурсов и запасов подземных вод Казахстана пополнена компьютерными макетами карт естественных запасов, прогнозных ресурсов, эксплуатационных запасов подземных вод Казахстана, а также компьютерными макетами карт обеспеченности подземными водами Республики Казахстан.

Карта распределения естественных запасов сформирована в пределах гидрогеологических массивов и бассейнов равнинных территорий. Карты прогнозных ресурсов отображают распределение подземных вод по минерализации в рамках различных площадей. Основные ресурсы пресных подземных вод (59,3%) сосредоточены в южном регионе: в Алматинской, Жамбылской, Кызылординской и Туркестанской областях, центральные, северные и западные регионы отличаются низкой величиной прогнозных ресурсов. Прогнозные эксплуатационные ресурсы подземных вод оценивались по гидрогеологическим бассейнам I и II порядков.

Для каждого типа территориальных объектов построены макеты карт распределения эксплуатационных запасов по целевому назначению, генетическим типам месторождений, категориям. Основное количество месторождений подземных вод разведано для хозяйственно-питьевого водоснабжения, а в ряде случаев – совместно для хозяйственно-питьевого и для других целей – орошения земель или технического водоснабжения. Основная величина эксплуатационных запасов подземных вод сосредоточена в конусах выноса предгорных шлейфов и межгорных впадин Южного и Юго-Восточного Казахстана. Наибольшие эксплуатационные запасы подземных вод (16721,778 тыс.м<sup>3</sup>/сут) характерны для Алматинской области, а наименьшие – для Северо-Казахстанской области.

Карты обеспеченности подземными водами отражают степень удовлетворения текущих и перспективных потребностей населения в питьевой воде за счет прогнозных ресурсов и разведанных эксплуатационных запасов подземных вод. Карты включают диаграммы соотношения величин прогнозных ресурсов подземных вод с различной минерализацией, эксплуатационных запасов подземных вод различных категорий,

извлечения подземных вод. Может быть сделан вывод об обеспеченности территории Казахстана прогнозными и утвержденными запасами подземных вод различного целевого назначения, хотя их неравномерность распространения создает в ряде районов дефицит пресных подземных вод.

Созданные макеты карт могут использоваться областными и республиканскими административными структурами в процессе прогнозирования развития экономики областей, планирования хозяйственной деятельности, разработки экологических мероприятий.

Информационная система является открытой и будет дополняться вариантами карт, построенными на основании различных методик расчета ресурсов подземных вод.

**Ключевые слова:** подземные воды, информационные системы, ресурсы подземных вод.

#### Information about authors:

Murtazin Yermek, Deputy Director of Satbayev University, Ahmedsafin Institute of Hydrogeology and Environmental Geoscience, PhD; ye\_murtazin@list.ru; <https://orcid.org/0000-0002-7404-4298>

Miroshnichenko Oxana, Leading Researcher of Satbayev University, Ahmedsafin Institute of Hydrogeology and Environmental Geoscience, PhD; o\_mirosh@mail.ru; <https://orcid.org/0000-0002-0057-6734>

Trushel Lyudmila, Senior Researcher of Satbayev University, Ahmedsafin Institute of Hydrogeology and Environmental Geoscience, PhD; lydmila\_y\_t@mail.ru; <https://orcid.org/0000-0002-9171-2761>

Smolyar Vladimir, Leading Researcher of “Kazecoproekt” LLP, Doctor of Geological and Mineralogical Sciences; v\_smolyar@mail.ru; <https://orcid.org/0000-0001-9419-048X>

Mirlas Vladimir, Researcher of Ariel University (Israel); Doctor of Geological and Mineralogical Sciences; vladimirmster@gmail.com; <https://orcid.org/0000-0002-3117-0331>

#### REFERENCES

[1] International Groundwater Resources Assessment Centre (2019). Global Groundwater Information System. <https://www.un-igrac.org/global-groundwater-information-system-ggis>

[2] Geolink Consulting (2019). Information and analytical system AquaBase. <http://www.geolink-consulting.ru/products/aquabase/>

[3] USGS (2020). Groundwater Data for the Nation. National Water Information System: Web Interface. <https://waterdata.usgs.gov/nwis/gw>

[4] Groundwater Dependent Ecosystems Atlas. <http://www.bom.gov.au/water/groundwater/gde/map.shtml>

[5] Zheng J. (2016) Towards Integrated Groundwater Management in China // In Book: Integrated Groundwater Management. Concepts, Approaches and Challenges. Springer International Publishing, Germany. DOI: 10.1007/978-3-319-23576-9, ISBN: 978-3-319-23575-2

[6] Ghosh P., Bandyopadhyay S., Jana N. (2016). Mapping of groundwater potential zones in hard rock terrain using geoinformatics: a case of Kumari watershed in western part of West Bengal, Modeling Earth Systems and Environment, Vol.2, 1: 1-12. DOI 10.1007/s40808-015-0044-z. ISSN 2363-6203

[7] Mirlas V. (2012). Assessing soil salinity hazard in cultivated areas using MODFLOW model and GIS tools: A case study from the Jezre'el Valley, Israel, Agriculture Water Management, 109: 144-154. DOI:10.1016/j.agwat.2012.03.003. ISSN: 0378-3774

[8] Murtazin E., Miroshnichenko O., Trushel L. (2018) Methods of making of geoinformational and analytical system of groundwater resources in Kazakhstan, News of Academy of Sciences of the Republic of Kazakhstan. Series of geology and technical sciences, 431: 21–31. <https://doi.org/10.32014/2018.2518-170X.6>. ISSN 2224-5278

[9] Veselov V., Panichkin V. (2004) Geoinformational-mathematical simulation of hydrogeological conditions of Eastern Priaralye. Complex, Kazakhstan. ISBN: 9965-471-92-4.

[10] Murtazin E., Miroshnichenko O., Trushel L. (2019) Structure of geoinformational and analytical system “Groundwater resources and reserves of the republic of Kazakhstan”, News of the Academy of sciences of the Republic Kazakhstan. Series of geology and technical sciences, 3: 21-29. <https://doi.org/10.32014/2019.2518-170X.63>, ISSN 2224-5278

[11] Murtazin E., Miroshnichenko O., Trushel L. Description of the informational system of groundwater resources and reserves of Kazakhstan. Proceedings of 19th International Multidisciplinary Scientific Geoconference SGEM 2019, Albena, Bulgaria. Vol. 19, Issue 1.2. P. 137-144. ISBN: 978-619-7408-77-5, ISSN: 1314-2704, DOI: 10.5593/sgem2019/1.2

[12] Yazvin A.L. (2015) Resource potential of fresh groundwaters of Russia (solution of modern problems of geological study) [Resursnyi potencial presnykh podzemnykh vod Rossii (reshenie sovremennykh problem geologicheskogo izucheniya)]. Dissertation for the degree of Doctor of Geological and Mineralogical Sciences, M., Russia (in Russ.).

[13] Veselov V.V. (2002) Hydrogeological zoning and regional assessment of groundwater resources in Kazakhstan [Gidrogeologicheskoye raionirovaniye i regional'naya otcenka resursov podzemnykh vod Kazakhstana]. Gylym, Kazakhstan. ISBN: 5-628-01116-9 (in Russ.).

[14] Smolyar V.A., Burov B.V., Mustafayev S.T. (2012). Groundwater resources of the Republic of Kazakhstan, In Book: Water Resources of Kazakhstan: assessment, forecast, management [Resursy podzemnykh vod Respubliki Kazakhstan v knige Vodnye resursy Kazakhstana: otcenka, prognoz, upravlenie]. Vol. VIII. Gylym, Kazakhstan. ISBN: 978-601-7150-27-3 (in Russ.).

[15] Sydykov Zh.S., Shlygina V.F. (1998). Groundwater of Kazakhstan. Structural and hydrogeological base and systematization [Strukturno-gidrogeologicheskaya osnova i sistematika]. Gylym, Kazakhstan. ISBN: 5-628-02250-0 (in Russ.).

[16] Absamenov M.K., Mukhamedzhanov M.A., Sydykov Zh.S., Murtazin E.Zh. (2017) Groundwater of Kazakhstan – a strategic resource for water security of the country [Podzemnyye vodyi Kazakhstana – strategicheskii resurs vodnoy bezopasnosti strany]. Nuray print service, Kazakhstan. ISBN: 978-601-280-826-1 (in Russ.).

[17] Smolyar V.A., Burov B.V., Veselov V.V. (2002). Water resources of Kazakhstan (Surface and groundwater, current state) [Vodnyie resursyi Kazakhstana (poverhnostnyie i podzemnyie vodyi, sovremennoe sostoyanie)]. Gylym, Kazakhstan. ISBN: 9965-07-125-X (in Russ.).

[18] Smolyar V.A., Isayev A.K. (2016) Undiscovered potential groundwater resources and usable groundwater reserves and their distribution over the territory of Kazakhstan [Prognozy i ekspluatatsionnyie zapasyi podzemnykh vod i ih raspredelenie po territorii Kazakhstana], Materials of the International scientific-practical conference “Water resources of Central Asia and their use”, devoted to summing up of the “Water for Life” decade declared by the United Nations, Almaty, Kazakhstan, Book 2. P. 238-246. ISBN: 978-601-7150-81-5 (in Russ.).

[19] Ostrovsky L.A., Antypko B.Ye., Konyukhova T.A. (1990) Methodical base of hydrogeological zoning of the USSR [Metodicheskie osnovy gidrogeologicheskogo rayonirovaniya territorii SSSR]. Nedra, Moscow, USSR (in Russ.).

[20] Scientific- Information Center of the Interstate Coordination Water Commission of the Central Asia (2016). General integrated water use and protection plan in the Republic of Kazakhstan, [www.eecca-water.net/content/view/7960/12/lang,russian/](http://www.eecca-water.net/content/view/7960/12/lang,russian/)

[21] Microsoft (2020). Microsoft Office. <https://www.office.com>

[22] ESRI (2020). ArcGIS. <https://www.esri.com>

[23] ESTI Map (2020). MapInfo Pro. [www.mapinfo.ru](http://www.mapinfo.ru)

## NEWS

OF THE NATIONAL ACADEMY OF SCIENCES OF THE REPUBLIC OF KAZAKHSTAN

SERIES OF GEOLOGY AND TECHNICAL SCIENCES

ISSN 2224-5278

Volume 2, Number 440 (2020), 123 – 131

<https://doi.org/10.32014/2020.2518-170X.39>

UDC 502.656

Zh. S. Mustafayev<sup>1</sup>, A. T. Kozykeyeva<sup>1</sup>, A. N. Kalmashova<sup>1</sup>,  
A. E. Aldiyarova<sup>1</sup>, Arvydas Povilaitis<sup>2</sup>

<sup>1</sup>Kazakh national agrarian university, Almaty, Kazakhstan;

<sup>2</sup>Vytautas Magnus University, Kaunas, Lithuania.

E-mail: z-mustafa@rambler.ru, aliya.kt@yandex.ru, abdikerimova\_89@mail.ru,  
ainur\_005@mail.ru, arvydas.povilaitis@vdu.lt

## ECOLOGICAL AND WATER ECONOMIC ASSESSMENT OF THE YESIL RIVER BASIN CATCHMENT AREA

**Abstract.** Based on the system analysis of the long-term information and analytical materials of the RSE «Kazhydromet» on water pollution in the Yesil river basin and the use of the Shannon index and the maximum pollution coefficient V.V. Shabanova made an assessment of water quality by hydrochemical indicators on a spatial and temporal scale in the conditions of anthropogenic activity to identify the causes and consequences of the formation of the hydrochemical regime of water bodies. On the basis of the conducted multivariate assessments and rationing of the water resources of the Yesil River, the directivity and intensity of changes in water quality, that is, their pollution with the main ions ( $Cl$ ,  $Na$ ,  $SO_4$ ), biogenic elements ( $NH_4$ ,  $NO_2$ ,  $NO_3$ ) and heavy metals ( $Cu$ ,  $Zn$ ) are shown on a spatial-temporal scale which are one of the main environment-forming systems for the life of the population of Central and Northern Kazakhstan. In this case, the maximum pollution coefficient ( $K_{n3}$ ) in the catchment area of the Yesil River Basin on a time scale from the hydrological station - the village of Turgenevka to the village of Dolamatova are increasing and, by degree of pollution, mainly refers to the contaminated and trophic status of E.S. Shannon - eutrophic, which must be considered when developing environmental protection measures to restore and improve the eco-capacity of water bodies in Central and Northern Kazakhstan.

**Key words:** analysis, assessment, pollution, water, state, hydrochemistry, system, elements, ions.

**Introduction.** At the present time, in the catchment area of the Yesil river basin, there is a difficult water-ecological situation, which is explained, first of all, by its transboundary position, and also due to the upper and middle parts of the basin to the arid inland regions of Northern Kazakhstan, where the river almost does not accept tributaries. The situation is aggravated by the fact that it is in these areas within Kazakhstan and the Russian Federation that the Yesil River is the main waterway and the source of water supply for the population and various sectors of the economy. The main areas of population, as well as industrial and agricultural development, are gravitated to its valley. Irrational economic activity in the catchment area, including the use of water resources, also has a great influence on the ecological status of the catchment area of the Yesil river basin.

Thus, the catchment area of the Esil river basin is under a multifactorial anthropogenic impact that affects the biotic and abiotic characteristics of them, and in order to effectively manage their hydro-ecological state, it is necessary to have long-term information and analytical data, characterizing the state of the managed system, which are obtained during hydrological, hydrochemical and hydrobiological observations of water bodies, as well as data on all significant factors affecting this state using methods of comprehensive assessment of the state of natural systems, allowing to evaluate water quality.

**The purpose of the research** – on the basis of long-term information and analytical materials of RSE «Kazhydromet» on the pollution of the water resources of the Yesil River, to determine the features of the formation of their hydrochemical regime in the conditions of anthropogenic activity.

**The object of research.** The Yesil River originates in the low Niyaz mountain range of the Kazakh Hills and over 775 km flows from east to west, receiving a number of large tributaries flowing from the Kokshetau Upland from the spurs of the Ulytau Mountains. In the upper reaches flows mainly to the north-west and west, mainly in a narrow valley, in the rocky shores [1].

Below Astana, the valley widens, south-westward beyond Atbasar. At 1578 km near the town of Derzhavinsk (conditional boundary of the upstream Yesil), the riverbed drastically changes its direction to the meridian - from south to north. Below Sergeevka, the river enters the West Siberian Plain and flows along the flat Yesil plain in a wide flood plain with numerous waters, in the lower reaches it flows among the marshes and flows into the Irtysh near the village of Ust-Yesil [2,3].

The Yesil river catchment area is 177,000 sq.km, of which about 20% of the area falls on the territory of Russia, within which about 30% of the flow is formed.

The main tributaries (on the territory of Kazakhstan): the right - Kalkutan, Zhabay, Akkanburlyk, Imanburlyk, the left - Terisakkan. The main tributaries of the Yesil (in Russia): the right - Karasul (flows into the Yesil, near the village of Burovoye), Ik, the left - Badger.

The catchment area of the Kalkutan River is 17,400 sq.km, length - 233 km, the average height of the catchment area is 360 m, and the density of the river network is 0,10 km / sq.km. The catchment area of the Zhabay River is 8,800 sq.km, the length is 196 km, the average height of the catchment is 364 m, and the density of the river network is 0,11 km/sq.km. The catchment area of the Terisakkan River is 19,500 sq.km, the length of the river is 334 km, the average height of the catchment is 350 m, and the density of the river network is 0,15 km / sq.km. The Akkanburlyk River originates from the Zhaksy-Zhangiztau lake from the west bank, flows into the Yesil river to the right at 1,280 km from the mouth, 1,176 km long, the catchment area is 6,720 sq.km, including 731 sq.km of non-flowing river, the total fall of the river is 188 m, average slope is 1%.

The Yesil river nourishment predominantly snow. The river freezes in early November, opens in April - May. The average water discharge at the village of Vikulovo 100 km from the mouth is 56,3 m<sup>3</sup>/s, the largest 686 cub.m/s. The maximum water discharge of the Yesil River in the upper reaches near the Astana city is 1080-1100 cub.m/s, the annual flow volume is 1,299,967 thousand m<sup>3</sup>/year. Average annual water consumption 1,11 cub.m/s.

The annual flow rate of the Yesil River, or the average long-term flow, is the main and stable characteristic that determines the total water content of the river and potential water resources[3].

The research of the regularity of the intra-annual distribution of the flow of the Yesil River is one of the most important issues, a solution that is necessary for the rational and integrated use of water resources for various purposes of the national economy. In general, the assessment of changes in the intra-annual distribution of runoff in a year depends not only on the methods of analyzing and comparing the monthly runoff and its distribution in a multiyear context with the dynamics of economic activity on the catchment area, but also to a certain extent on comparing the natural and disturbed flow distribution. In general, the relative stability of the intra-annual and seasonal distribution of the flow of the Yesil River in natural conditions is confirmed by data on the relative distribution of the flow over the seasons in the context of weak economic development of the region and after the construction of large reservoirs (figures 1, 2).

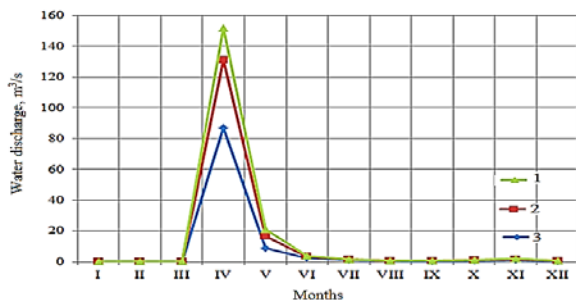

Figure 1 – Intra-annual distribution of the flow of the Yesil River (Astana gauging station) of different supply (1-25%; 2-50%; 3-75%)

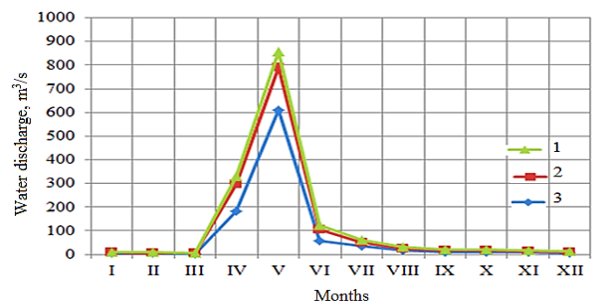

Figure 2 – Intra-annual distribution of the flow of the Yesil River (Peropavlovsk hydropost) of various types of supply (1-25%; 2-50%; 3-75%)

One of the factors affecting the formation of the socio-economic complex of the Yesil river basin catchment is the development of economic activity, that is, the main water consumers are agriculture (regular and estuarial irrigation, hayfield, agricultural water supply, watering of pastures), industry and the housing sector.

The volume of water consumption within the Republic of Kazakhstan is currently about 217,7 million cub.m and by 2020 the volume of water consumption will increase to 480,2 million cub.m.

Water consumption in the Russian part of the Yesil River Basin is an order of magnitude less than in the Republic of Kazakhstan, its volume currently stands at 16,0 million cub.m, an increase by 2020 is planned to 28 million cub.m [1].

Very high population density among the Akmola and North Kazakhstan regions, which constitute 12,46 people/sq.km, a high share of industrial production of 36,5 thousand dollars/sq.km, the maximum plowing of the territory (60%) and livestock loading in the range of 14,6 head/sq.km showed that within the Republic of Kazakhstan the catchment area of the Yesil River basin has an average degree of anthropogenic load. At the same time, the largest anthropogenic load falls on large industrial cities, the average is typical for agricultural areas, low prevails in areas with low population density [1].

The magnitude of the load on water resources is estimated by the coefficient of water use ( $K_{u\epsilon p}$ ), equal to the ratio of total water consumption to available water resources, showed that the largest water load falls on large industrial cities and amounts to 40%, which corresponds to a high load, and in general the Esil river basin on average, water loads make up 14 -16%, which characterizes a moderate load on water resources.

Changes in the quality of water resources in the Yesil river basin occur under the influence of a number of reasons, the main of which was the development of economic sectors and, as a result, environmental pollution and water bodies. At the same time, the main sources of pollution of water resources in the watershed of the Yesil river basin, that is, from the sources of rivers to the Sergeevsky reservoir, are industrial, household and mine sewage of enterprises of Karaganda-Temirtau industrial region [1].

In the Yesil river basin, the total volume of discharges is currently 94,28 million cub.m, including 26,34 million cub.m to natural surface water bodies. The main part of the discharge was wastewater – 86,62 million cub.m and mine- 6,40 million cub.m, collector-drainage water is formed in an insignificant amount – 1,26 million cub.m. In the future, a significant increase in total discharge is projected at 134,87 million cub.m, that is, up to 229,15 million cub.m, but the increase in natural surface water bodies is expected to be insignificant, only by 1,28 million cub.m. The main increase in discharges will occur due to wastewater, the volume of which will increase by 120,19 million cub.m [1].

**Research materials.** When solving the tasks set in the work, the long-term information and analytical materials «Annual data on the quality of surface waters» of the Republic of Kazakhstan of the RSE «Kazgidromet» and the Newsletter of the RSE «Kazgidromet» «On the state of the environment in the Republic of Kazakhstan» of MEWR RK in the period 1990-2012 were used years and studies of perennial stock and literature sources on hydrochemical indicators [4,5], including biochemical oxygen consumption ( $BOD_5$ ), ammonia nitrogen ( $NH_4$ ), nitrite nitrogen ( $NO_2$ ), nitrate-nitrogen ( $NO_3$ ), chlorides ( $Cl$ ), sulfates ( $SO_4$ ), copper ( $Cu$ ), zinc ( $Zn$ ), natrium ( $Na$ ) and petroleum products. The research methods of RSE "Kazgidromet" of the Republic of Kazakhstan are based on systematization, system analysis and synthesis of monitoring results, which were carried out on the basis of the "Manual hydrometeorological stations and posts (part 3.1 - Hydrological observations at posts. Almaty, 2004)", according to which observations on transboundary sections are held at least 36 times a year [6].

At the same time, Horiba U-50 series (measuring the physicochemical parameters of water), the bottom grab gear and Peterson (for sampling macrozoobenthos) and the Jedi network (for sampling zooplanktons) were used to determine hydrobiological indicators and sampling.

**Research methods.** For evaluation and standardization of water quality in the river basins in the Americas and Europe uses water quality index CCME (CCQE WQI) - it is a tool to simplify the presentation of water quality data [7] as the only tool for managing water bodies. A significant contribution to the development of the theoretical base of the water quality index CCME (CCQE WQI) have been made by D. Couillard and Y. Lefebvre[8], D.G. Smith [9], M.A. House and J.B. Ellis [10], J. Saeger [11], P.A. Zandbergen and K.J. Hall [12], S. Hébert [13], R. Rocchini and L.G. Swain [14], S. Munger [15], W. Hart [16], B. Phippen [17], T. Husain [18], C.R. Wright, K.A. Saffran, A-M. Anderson, D. Neilson,

N.MacAlpine and S. Cooke [19], H. Khan [20], as well as some work done by Canadian scientists W. Hart, Earle Baddaloo, Jackie Shaw, Kim Hallard, Murray Hilderman, Peter Rodgers, Karl Lauten, Ilze Reiss and Herb Vandermeulen, Scott Tessier and Margaret Gibbs in the implementation of the project «Canadian recommendations on water quality for the protection of aquatic life and fauna: water quality index CCME» [7].

For assessing the quality of water resources and the ecological state of aquatic ecosystems in the practice of water management in the Russian Federation and the Republic of Kazakhstan, methods based on the use of complex indicators, that is, the definition of limits of permissible changes (LPC) are widely used [21], critical threshold action (CTA) [22], maximum permissible concentration (MPC) [22], hydrochemical pollution index (HPI) [22], as well as methodological support of N.G. Bulgakov [23], V.P. Yemelyanova [24], T.N. Moiseenko [25], M.Zh. Burlibayev [26] and V.V. Shabanov [27].

In this case, to assess the water quality and ecological status of water bodies in the Yesil river basin, the method of V. Shabanov is used, by using the maximum pollution coefficient ( $K_{n3}$ ) [27-29]:

$$K_{n3} = \frac{1}{N} \cdot \sum_{i=1}^N \frac{C_i}{MPC_i} - 1$$

where  $i$  – number of the water pollutant;  $N$  - quantity of substances taken into account;  $MPC_i$  - maximum permissible concentration of substances to be taken into account;  $C_i$  - actual concentration of substances taken into account;  $K_{n3}$  - coefficient of pollution that characterizes water quality, the state of the river water body and its water management value, which are estimated in accordance with the classification given in table 1.

Table 1 – Classification of water quality according to the coefficient of maximum pollution ( $K_{n3}$ )

Very clean	Clean	Moderately clean	Polluted	Unclean	Very clean
<-0.80	-0.80-0.0	0.0-1.0	1.0-3.0	3.0-5.0	>5.0

To assess the degree of water pollution in river basins used trophic status of E.S. Shannon (table 2) [30].

Table 2 – Classification of water quality index by Shannon ( $H$ ) [30]

Trophic					
Oligotrophic	Mesotrophic	Meso Eutrophic	Eutrophic	Polytrophic	Hyper eutrophic
3,06-1,89	1,89-1,69	1,69-1,52	1,52-1,35	1,35-1,25	1,25-1,11

**Research results:** Based on the methodological approach of V.V. Shabanov based on the coefficient of maximum pollution ( $K_{n3}$ ) with the use of long-term information and analytical materials of RSE «Kazhydromet» on water pollution in the Yesil river basin and integral maximum allowable concentration criteria (MAC) for fishery water use [3; 4; 31] the water quality was assessed by hydrochemical parameters (figure 3 and 4).

Thus, the assessment of the quality of water in the catchment area of the Yesil river basin carried out on a spatial-temporal scale, starting with the flow formation zone (hydrological station Turgenevka) to the mouth of the river (hydrological station Dolamatova), made it possible to determine the directivity and intensity of their pollution with the main ions (Cl, Na, SO<sub>4</sub>), biogenic elements (NH<sub>4</sub>, NO<sub>2</sub>, NO<sub>3</sub>) and heavy metals (Cu, Zn). As can be seen from table 3, the waters in the catchment area of the Yesil river basin are mainly polluted with heavy metals (Cu, Zn), sulfates (SO<sub>4</sub>) and petroleum products, which requires the need to take into account when developing environmental protection measures. It should be noted that the coefficient of maximum contamination ( $K_{n3}$ ) in the watershed of the Yesil River Basin on a time scale from the hydrological station, the village of Turgenevka to the village of Dolamatovo increases and by degree of pollution, mainly refers to polluted (Figure 3), where the water pollution is represented by the trophic status of E.S. Shannon [30].

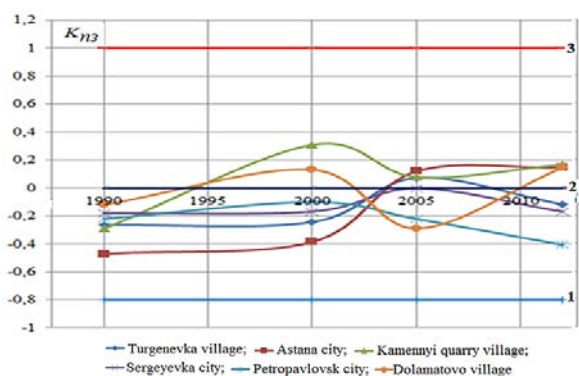

Figure 3 – Changes in water quality according to the limiting pollution factor in the Yesil river catchment area in the space-time scale: 1 - very clean (oligotrophic); 2- pure (mesotrophic); 3 - moderately polluted (meso-eutrophic)

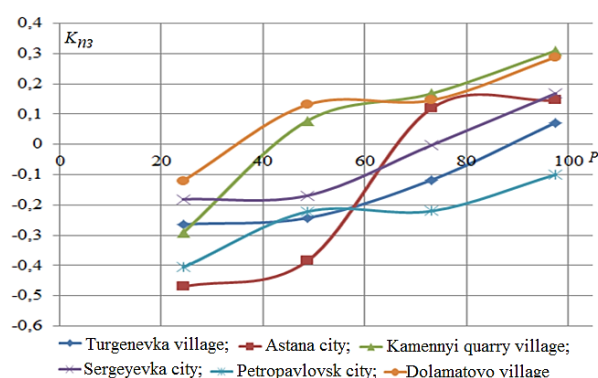

Figure 4 – The probability curve of the coefficient of maximum pollution ( $K_{n3}$ )

As can be seen from figure 3, water quality assessment by pollution factor was carried out in a multiyear section (1990-2012) and on a spatial scale, which allowed us to obtain water quality characteristics for years of varying degrees of supply and various hydrological posts located along the catchment area of the Yesil basin (figure 4).

To assess the ecological state of the aquatic ecosystem in the catchment area of the Yesil river basin the Shannon index ( $H$ ) dependence is used and pollution limit coefficient of V.V. Shabanov ( $K_{n3}$ ), which has the following form:  $H = 3,06 \cdot \exp[-0.23(K_{n3} + 2)]$ .

Based on the coupling equation characterizing the dependence of the Shannon index and the pollution limit coefficient ( $K_{n3}$ ) their quantitative values were determined by hydrological posts located in the catchment area of the Yesil river basin on a time scale (table 3).

Table 3 – Comparative assessment of the ecological state of the aquatic ecosystem in the catchment area of the Yesil river basin using the Shannon index ( $H$ ) and coefficient of maximum pollution ( $K_{n3}$ )

Hydrological posts	Years							
	1990		2000		2005		2012	
	$K_{n3}$	$H$	$K_{n3}$	$H$	$K_{n3}$	$H$	$K_{n3}$	$H$
Turgenevka village	-0,264	2,050	-0,243	2,041	0,072	1,900	-0,117	1,983
Astana city	-0,470	2,151	-0,385	2,111	0,120	1,876	0,146	1,867
Kamennyi quarry village	-0,291	2,066	0,309	1,799	0,078	1,897	0,168	1,860
Sergeyevka city	-0,181	2,013	0,168	1,860	-0,002	1,934	-0,169	2,007
Petropavlovsk city	-0,222	2,032	-0,100	1,977	0,220	1,836	-0,406	2,121
Dolamatovo village	-0,120	1,986	0,131	1,876	0,288	1,805	0,146	1,870

Thus, on the basis of systematization and system analysis, as well as predictive calculations to determine the pollution limit index and the Shannon index, it was possible to evaluate the water quality and ecological state of the aquatic ecosystem in the Yesil river basin in the space-time scale, that is, the water quality in all hydrological posts are estimated at the level of «moderately polluted (mesoeutrophic)» and «polluted (eutrophic)».

**Discussion.** Currently, the hydrological regime of the Yesil river basin has changed under the influence of anthropogenic activities, that is, 80% of the river flow is completely regulated by the construction of large and small reservoirs to meet the water needs of growing and developing industrial facilities, cities and agriculture.

The volume of water consumption within the Republic of Kazakhstan is currently about 217.7 million cub.m and by 2020 the volume of water consumed will increase to 480.2 million cub.m.

Most of the wastewater from the Esil river basin is formed in the catchment areas of the Kazakhstan part, which in the future from 134.87 million cub.m to 229.15 million cub.m, are the main sources of chemical and biogenic pollution of surface runoff.

The magnitude of the load on water resources was estimated by using the coefficient of water resources use ( $K_{исп}$ ), equal to the ratio of total water consumption to available water resources showed that the largest water load falls on large industrial cities and makes up to 40%, which corresponds to a high load, and in general, the Yesil river basin has an average water load of 14 -16%, which characterizes moderate load on water resources.

The quality of water in the catchment area of the Yesil river basin carried out on a space-time scale, starting from the runoff formation zone (hydrological station Turgenevka) to the mouth of the river (hydrological station Dolamatovo), made it possible to determine the direction and intensity of their contamination with the main ions (Cl, Na, SO<sub>4</sub>), biogenic elements (NH<sub>4</sub>, NO<sub>2</sub>, NO<sub>3</sub>) and heavy metals (Cu, Zn). At the same time, it is mostly contaminated with heavy metals (Cu, Zn), sulfates (SO<sub>4</sub>) and oil products, which requires the need to take into account when developing environmental protection measures. It should be noted that the coefficient of maximum pollution ( $K_{нз}$ ) in the catchment area of the Yesil river basin on a time scale from the hydrological station of the Turgenevka village to the Dolamatovo village increases.

Assessing water quality and the ecological status of the aquatic ecosystem in the Yesil watershed by using the coefficient of maximum pollution ( $K_{нз}$ ) and Shannon index ( $H$ ) allowed to determine the degree, intensity, direction and nature of pollution of water bodies in the space-time scale and to obtain the dependence of the coefficient of maximum pollution ( $K_{нз}$ ) and Shannon index ( $H$ ) in the estimated provision ( $P$ ), which showed that the quality of water for all the considered hydrological posts is estimated at the level of «moderately polluted (mesoeutrophic)» and «polluted (eutrophic)».

At the same time, the obtained information on the current state of the aquatic ecosystem of the catchment area of the Yesil river basin within the Republic of Kazakhstan makes it possible to develop a system of measures for the rational use of natural resources and the prevention of possible emergency situations based on the quantitative characteristics of natural self-purification.

**Ж. С. Мұстафаев<sup>1</sup>, Ә. Т. Қозыкеева<sup>1</sup>, А. Н. Калмашова<sup>1</sup>,  
А. Е. Алдиярова<sup>1</sup>, Арвидас Повилайтис<sup>2</sup>**

<sup>1</sup>Қазақ ұлттық аграрлық университеті, Алматы, Қазақстан;

<sup>2</sup>Витовта Великого университеті, Каунас, Литва

### **ЕСІЛ ӨЗЕНІНІҢ СУ ЖИНАУ АЛАБЫН ЭКОЛОГИЯЛЫҚ-СУ ШАРУАШЫЛЫҚ ТҮРҒЫДА БАҒАЛАУ**

**Аннотация.** Қазіргі уақытта Есіл өзенінің бассейнінде күрделі су-экологиялық жағдай орын алған, бұл, ең алдымен, шекарааралық орналасуымен, сонымен қатар өзен бассейнінің жоғарғы және ортаңғы бөлігінің Солтүстік Қазақстанның құрғақ жерлерімен байланысты болуымен түсіндіріледі. Жағдайды одан әрі ушықтыратын мәселе Қазақстан мен Ресей Федерациясының шегінде Есіл өзені халықты және экономиканың әртүрлі салаларын, тұрғындардың негізгі аудандарын, сондай-ақ өнеркәсіптік және ауылшаруашылық дамуын магистральдық су жолы және сумен қамтамасыз ету көзі болып табылады. Су жинау алабындағы су ресурстарын тиімсіз пайдалануды ескеретін болсақ, Есіл өзені бассейнінің экологиялық жағдайына үлкен әсер етеді.

Есіл өзенінің бассейніндегі төгінді сулардың көп бөлігі Қазақстан бөлігінің су жинау учаскелерінде қалыптасады, олар болашақта 134,87 млн м<sup>3</sup>-ден 229,15 млн м<sup>3</sup>-ге дейін беткі ағынды ластаудың химиялық және биогендік негізгі көздері болып табылады.

Ақмола және Солтүстік Қазақстан облыстары арасында халықтың тығыздығы 12,46 адам/км<sup>2</sup>, өнеркәсіп өндірісінің жоғары үлесі 36,5 мың доллар / км<sup>2</sup>, аумақта жерді жыртудың жоғарғы көрсеткіші (60%) және 14,6 мал басы/км<sup>2</sup> жағдайдағы мал басының жүктемесі Қазақстан Республикасының аумағында Есіл өзені су жинау алабында антропогендік жүктеменің едәуір жоғары екендігін көрсетті, бұл жер үсті су ресурстарының химиялық және биогенді ластануының қалыптасуына әсер етеді.

Осылайша, Есіл өзенінің су жинау алабы оның биотикалық және абиотикалық сипаттамаларына әсер ететін көп факторлы антропогендік әсерде болады, өзеннің гидроэкологиялық жағдайын тиімді басқару үшін

су нысандарына гидрологиялық, гидрохимиялық және гидробиологиялық зерттеулер жүргізу кезінде алынған бақыланатын жүйенің жағдайын сипаттайтын ұзақ мерзімді ақпараттық және аналитикалық мәліметтер болуы қажет, сонымен қатар оған әсер ететін барлық маңызды факторлар туралы мәліметтер бірге судың сапасын анықтауға мүмкіндік беретін табиғи жүйенің жағдайын жан-жақты бағалау әдісін пайдалану қажет.

Мақалада Есіл өзенінің бассейніндегі судың ластануы туралы «Қазгидромет» РМК ұзақ мерзімді ақпараттық-аналитикалық материалдарының жүйелік талдауы, Шеннон индексі мен В.В. Шабановтың максималды ластану коэффициенті негізінде су нысандарының кеңістік-уақыт масштабындағы гидрохимиялық көрсеткіштері бойынша судың сапасы бағаланып, антропогендік әсер кезінде гидрохимиялық режимінің пайда болу себептері мен салдарын анықталды. Есіл өзенінің су ресурстарын кеңістіктік-уақыттық масштабта бағалау үшін жүргізілген зерттеулер негізінде су ресурстарының жүктемесі су ресурстарын пайдалану коэффициентін ( $K_{иср}$ ) колдана отырып, су ресурстарының жалпы суды тұтынудың қол жетімді су ресурстарына қатынасы арқылы есептелген, ең үлкен су жүктемесі ірі өнеркәсіптік қалаларға 40% дейін жетті, бұл жоғары жүктемеге сәйкес келеді, ал жалпы Есіл өзенінің бассейнінде су жүктемесі орташа есеппен 14 -16% құрады, бұл су ресурстарына түсетін жүктеменің қалыпты жағдайын сипаттайды.

Есіл өзенінің су ресурстарына кеңістік-уақыт масштабында жүргізілген көп дәлелдемелі бағалаудың және мөлшерлеудің негізінде судың сапасының өзгеруінің бағыты және қарқыны көрсетілген, яғни Орталық және Солтүстік Қазақстанның тұрғындарының тіршілік қызметінің орта жүйесін құрушы негізгі иондармен (Cl, Na, SO<sub>4</sub>), биогендік элементермен (NH<sub>4</sub>, NO<sub>2</sub>, NO<sub>3</sub>) және ауыр металдармен (Cu, Zn) ластану дәрежесі көрсетілген. Сонымен, Есіл өзенінің сужинау алабының уақыт масштабындағы шектелген ластану көрсеткіші ( $K_{из}$ ) Тургеневка ауылының тұсындағы гидрологиялық бекеттен Доламаты ауылына дейін ластану дәрежесі өседі және ластану дәрежесі бойынша лас және Е.С. Шенноның трофикалық мәртебесі бойынша эвтрофикалық топқа жатады, ал бұның өзін Орталық және Солтүстік Қазақстанның су нысандарының экологиялық сымдылығын қалпына келтіру және жақсартуға арналған табиғаты қорғау шараларын құру кезінде ескеру керек.

Сонымен қатар, Қазақстан Республикасындағы Есіл өзені бассейнінің су айдынының су экосистемінің қазіргі жағдайы туралы алынған ақпарат табиғи ресурстарды ұтымды пайдалану және мүмкін болатын төтенше жағдайлардың алдын алу бойынша шаралар жүйесін табиғи жүйелерді табиғи өзін-өзі тазарту процестерінің сандық сипаттамаларына сүйене отырып жасауға мүмкіндік береді.

**Түйін сөздер:** талдау, бағалау, ластану, су, жағдайы, гидрохимия, жүйе, элемент, иондар.

**Ж. С. Мустафаев<sup>1</sup>, А. Т. Козыкеева<sup>1</sup>, А. Н. Калмашова<sup>1</sup>,  
А. Е. Алдиярова<sup>1</sup>, Арвидас Повилайтис<sup>2</sup>**

<sup>1</sup>Казахский национальный аграрный университет, Алматы, Казахстан;

<sup>2</sup>Университет Витовта Великого, Каунас, Литва

## ЭКОЛОГО-ВОДОХОЗЯЙСТВЕННАЯ ОЦЕНКА ВОДОСБОРА БАСЕЙНА РЕКИ ЕСИЛЬ

**Аннотация.** В настоящее время в водосборе бассейна реки Есиль сложилась сложная водно-экологическая обстановка, что объясняется, прежде всего, его трансграничным положением, а также приуроченностью к верхней и средней частям бассейна к засушливым внутриконтинентальным районам Северного Казахстана, где река почти не принимает притоков. Усугубляет ситуацию то, что именно на этих участках в пределах Казахстана и Российской Федерации река Есиль является основной водной артерией и источником водообеспечения населения и различных отраслей хозяйства, к его долине тяготеют основные ареалы заселённости, а также промышленной и сельскохозяйственной освоенности. Нерациональная хозяйственная деятельность на водосборе, включая использование водных ресурсов, также оказывает большое влияние на экологическое состояние водосбора бассейна реки Есиль.

Большая часть сточных вод бассейна реки Есиль формируется в водосборных территориях казахстанской части, которая в перспективе от 134,87 млн. м<sup>3</sup> до 229,15 млн. м<sup>3</sup>, являются основными источниками химического и биогенного загрязнения поверхностного стока.

Очень высокая плотность населения среди Акмолинской и Северо-Казахстанской областей, которые составляют 12,46 чел/км<sup>2</sup>, высокая доля промышленного производства 36,5 тыс. доллар/км<sup>2</sup>, максимальная распаханность территории (60 %) и животноводческой нагрузки в пределах 14,6 усл. гол/км<sup>2</sup> показали, что в пределах Республики Казахстан водосборный бассейн реки Есиль имеет достаточно высокую антропогенную нагрузку, оказывающую влияние на формирования химических и биогенных загрязнений поверхностных водных ресурсов.

Таким образом, водосбор бассейна реки Есиль находится под многофакторным антропогенным воздействием, которое воздействует на биотические и абиотические их характеристики, что для эффективного управления их гидроэкологическим состоянием необходимо иметь многолетние информационно-анали-

тические данные, характеризующие о состоянии управляемой системы, которые получают при проведении гидрологических, гидрохимических и гидробиологических наблюдений за водными объектами, а также данные обо всех существенных факторах влияния на это состояние с использованием методов всесторонней оценки состояния природных систем, позволяющих оценить качество воды.

В статье на основе системного анализа многолетних информационно-аналитических материалов РГП «Казгидромет» по загрязнению воды в бассейне реки Есиль и использования индекса Шеннона и коэффициента предельной загрязненности В.В. Шабанова произведена оценка качества воды по гидрохимическим показателям в пространственно-временном масштабе в условиях антропогенной деятельности для выявления причин и следствия формирования гидрохимического режима водных объектов. На основе проведенных многофакторных оценок и нормирования водных ресурсов реки Есиль в пространственно-временном масштабе величина нагрузки на водные ресурсы оценивалась через коэффициент использования водных ресурсов ( $K_{иср}$ ), равный отношению полного водопотребления к располагаемым водными ресурсам показал, что наибольшая водная нагрузка приходится на крупные промышленные города и составляют до 40%, что соответствует высокой нагрузке, а в целом бассейн реки Есиль в среднем водные нагрузки составляют 14 - 16%, что характеризует умеренную нагрузку на водные ресурсы.

Качество воды в водосборе бассейна реки Есиль проведенного в пространно-временном масштабе, начиная с зоны формирования стока (гидрологический пост село Тургеневка) до устья реки (гидрологический пост село Доламаты) позволило определить направленности и интенсивности их загрязнения главными ионами (Cl, Na, SO<sub>4</sub>), биогенными элементами (NH<sub>4</sub>, NO<sub>2</sub>, NO<sub>3</sub>) и тяжелыми металлами (Cu, Zn). При этом в основном загрязнена тяжелыми металлами (Cu, Zn), сульфатами (SO<sub>4</sub>) и нефтепродуктами, что требует необходимости учитывать при разработке природоохранных мероприятий. При этом следует отметить, что коэффициент предельной загрязненности ( $K_{пз}$ ) в водосборе бассейна реки Есиль во временном масштабе от гидрологического поста село Тургеневка до села Доламаты увеличивается.

Оценки качества воды и экологического состояния водной экосистемы в водосборе бассейна реки Есиль с использованием коэффициента предельной загрязненности ( $K_{пз}$ ) и индекса Шеннона ( $H$ ) позволили определить степень, интенсивность, направленность и характер загрязнения водных объектов в пространственно-временном масштабе и получить зависимость коэффициента предельной загрязненности ( $K_{пз}$ ) и индекса Шеннона ( $H$ ) в расчетной обеспеченности ( $P$ ), которая показала, что качество воды по всех рассматриваемых гидрологических постах оценивается на уровне «умеренно-загрязненная (мезоэвтрофные)» и «загрязненная (эвтрофные)».

При этом полученная информация по современному состоянию водной экосистемы водосборной территории бассейна реки Есиль в пределах Республики Казахстан дает возможность разработать систему мероприятий по рациональному природопользованию и предотвращению возможных чрезвычайных ситуаций на основе количественной характеристики процессов естественного самоочищения природных систем.

**Ключевые слова:** анализ, оценка, загрязнение, вода, состояние, гидрохимия, система, элементы, ионы.

#### Information about authors:

Mustafayev Zhumakhan Suleimenovich, Doctor of Technical Sciences, Professor, Professor of the Department «Water Resources and Melioration», Kazakh National Agrarian University; z-mustafa@rambler.ru; <https://orcid.org/0000-0003-2425-8148>

Kozykeyeva Aliya Tobazhanovna, Doctor of Technical Sciences, Associate Professor, Professor of the Department «Water Resources and Melioration», Kazakh National Agrarian University; aliya.kt@yandex.ru; <https://orcid.org/0000-0003-0581-0881>

Kalmashova Ainur Nurlepesovna, Document PhD of the Department «Water Resources and Land Reclamation», Kazakh National Agrarian University; abdikerimova\_89@mail.ru; <https://orcid.org/0000-0001-6889-0474>

Aldiyarova Ainura Esirkepovna, PhD, Senior Lecturer of the Department of «Water Resources and Melioration», Kazakh National Agrarian University; ainur\_005@mail.ru; <https://orcid.org/0000-0002-6017-5182>

Arvydas Povilaitis, doctor of technical sciences, professor, Vytautas Magnus University, Kaunas, Lithuania; arvydas.povilaitis@vdu.lt; <https://orcid.org/0000-0003-1285-4604>

#### REFERENCES

[1] Frolova N.L., Ivanovskaya V.V. Features of water use in the conditions of water resources shortage (on the example of the Ishim river) // Water Management of Russia, 2015. N 2. P. 4-19.

[2] Water resources of Kazakhstan: assessment, forecast, management: in 21 volumes. Almaty, 2012. Vol. V: The climate of Kazakhstan is the basis for the formation of water resources / Under scientific. ed. Salnikova V.G. 430 p.

[3] Water resources of Kazakhstan: assessment, forecast, management: in 21 volumes. Almaty, 2012. Vol. VII: Resources of a river flow of Kazakhstan. Book 1: Renewable surface water resources of Western, Northern, Central and Eastern Kazakhstan / Under scientific. Ed. R.I. Halperin. 684 p.

[4] Burlibayev M.Zh., Amirgaliev N.A., Schoenberger I.V., Sokalsky V.A., Burlibayeva D.M., Uvarov D.V., Simernova D.A., Efimonko A.V., Milyukov D.YU. Pollution problems in the main transboundary rivers of Kazakhstan. Almaty: Kanagat, 2014. Vol. 1. 742 p.

- [5] Burlibayev M.Zh., Murtazin E.Zh., Iskakov N.A., Kudekov T.K., Bazarbayev S.K. Nutrients in the main watercourses of Kazakhstan. Almaty: Kanagat, 2003. 723 p.
- [6] Instructions to hydrometeorological stations and posts. Part 3.1. Hydrological observations at posts. Almaty. 2004.
- [7] Canadian Water Quality Guidelines for the Protection of Aquatic Life // CCME WATER QUALITY INDEX 1.0 Technical Report (Canadian Environmental Quality Guidelines Canadian Council of Ministers of the Environment), Canadian Council of Ministers of the Environment 2001 Excerpt from Publication No. 1299; ISBN 1-896997-34-1.
- [8] Couillard D. and Lefebvre Y. 1985. Analysis of water quality indices. *J. Environ. Mgmt.* 21: 161-179.
- [9] Smith D.G. 1990. A better water quality indexing system for rivers and streams. *Wat. Res.* 24 (10): 1237-1244.
- [10] House M.A. and Ellis J.B. 1987. The development of water quality indices for operational management. *Water Sci. Technol.* 19 (9): 145-154.
- [11] Saeger J. 1994. Developments in water quality standards and classification schemes in England and Wales. *Water Sci. Technol.* 30: 11-19.
- [12] Zandbergen P.A. and Hall K.J. 1998. Analysis of the British Columbia Water Quality Index for watershed managers: A case study of two small watersheds. *Water Qual. Res. J. Canada.* 33 (4): 519-549.
- [13] Hébert S. 1996. Développement d'un indice de la qualité bactériologique et physico-chimique de l'eau pour des rivières du Québec. Report of the Ministère de l'Environnement et de la Faune.
- [14] Rocchini R. and L.G. Swain. 1995. The British Columbia Water Quality Index. Water Quality Branch, Environmental Protection Department, British Columbia Ministry of Environment, Land and Parks. 13 p.
- [15] Munger S. 1996. A Canadian water quality index: A discussion paper for obtaining relevant national data and the refinement of methods. Prepared for Indicators Branch, State of the Environment Directorate, Environment Canada. 12 p. + tables and graphs.
- [16] Hart W. 1998. Alternative formulations of factors used in the British Columbia Water Quality Index. Report submitted to the Technical Subcommittee of the CCME Water Quality Guidelines Task Group. February, 1998.
- [17] Phippen B. 1998. Application of the National Water Quality Index prototype in British Columbia. BWP Consulting, 60 p. June, 1998.
- [18] Husain T. 1998. Application of the National Water Quality Index prototype in Newfoundland. Prepared for State of the Environment Task Group, Canadian Council of Ministers of the Environment. 57 p. May, 1998.
- [19] Wright C.R., Saffran K.A., Anderson A-M., Neilson D., MacAlpine N., and Cooke S. 1998. A Water Quality Index for Agricultural Streams in Alberta. 17 p. + appendices. November, 1998.
- [20] Khan H. The CCME Water Quality Index 1.0 - Application to Three Watersheds in Newfoundland. November 1999.
- [21] Kalikhman A.D., Pedersen A.D., Savenkova T.P., Suknev A.Ya. The method of "limits of permissible changes" on Lake Baikal - UNESCO World Heritage Site. Irkutsk: Reprint, 1999.
- [22] Sanitary rules and standards for the protection of surface waters from pollution. M.: Ministry of Health of the USSR. 1988. 74 p.
- [23] Bulgakov N.G. Ecologically permissible levels of abiotic factors in water bodies of Russia and adjacent countries. Dependence on geographical and climatic features // *Water Resources*, 2004. Vol. 31, N 2. P. 193-198.
- [24] Emelyanova V.P., Danilova G.N., Rodziller I.D. A method of summarizing the indicators for assessing the quality of surface water // *Hydrochemical materials*, 1980. Vol. 77. P. 88-96.
- [25] Moiseenko T.I. Methodical approaches to the regulation of anthropogenic load on the Subarctic water bodies (on the example of the Kola North) // *Problems of chemical and biological monitoring of the ecological status of water bodies of the Kola North*. Appatity: Kola Science Center, 1995. P. 7-23.
- [26] Burlibayev M.J., Fachevsky B.V., Opp K., Burlibayeva D.Zh., Kaydarova R.K., Vagapova A.R. Scientific basis for rationing the ecological flow of rivers of Kazakhstan. Almaty, 2014. 408 p.
- [27] Shabanov V.V., Markin V.N. Method for assessing water quality and the status of aquatic ecosystems. M.: MGUP, 2009. 154 p.
- [28] Vershinskaya M.E., Shabanova V.V., Markin V.N. Ecological and water management assessment of the catchment and water bodies in the Irtysh basin // *Nature Management*, 2008. N 2. P. 50-57.
- [29] Mustafayev Zh.S., Kozykeyeva A.T., Maymekov Z.K., Abdyvaliyeva K.S. Geocological assessment of the transformation of the concentration of pollutants in the water in the lower reaches of the Syrdarya River in the conditions of anthropogenic activity // *International Technical and Economic Journal*, 2016. N 5. P. 41-47.
- [30] Shannon, C.E., Warren Weaver. The mathematical theory of communication. Urbana: the University of Illinois Press. 1949. 117p.
- [31] Mustafaev Zh.S., Kozykeyeva A.T., Zhanymkhan K., Aldiyarova A.E., Mosiej Józef. The methods of assessment of maximum allowable impacts ecologically on small rivers // *N E W S of the National Academy of Sciences of the Republic of Kazakhstan series of geology and technical sciences*. Vol. 2, N 434 (2019), 30-38. <https://doi.org/10.32014/2019.2518-170X.35>

**NEWS**

OF THE NATIONAL ACADEMY OF SCIENCES OF THE REPUBLIC OF KAZAKHSTAN

**SERIES OF GEOLOGY AND TECHNICAL SCIENCES**

ISSN 2224-5278

Volume 2, Number 440 (2020), 132 – 140

<https://doi.org/10.32014/2020.2518-170X.40>

UDC 556.38;38.61.31

**S. Osipov<sup>1</sup>, A. Yermenbai<sup>1</sup>, A. Akylbekova<sup>1</sup>, Yu. Livinsky<sup>1</sup>, Oitore Anarbekov<sup>2</sup>**

<sup>1</sup>Satbayev University, Ahmetsafin Institute of Hydrogeology  
and Environmental Geoscience, Almaty, Kazakhstan;

<sup>2</sup>IWMI-Central Asia, Tashkent, Uzbekistan.

E-mail: osvosv@rambler.ru; ms.ermenbay@mail.ru; aigul\_igg@mail.ru;  
livinskii\_yur@mail.ru; anarbekov@yahoo.com

## **THE NEGATIVE IMPACT OF ANTHROPOGENIC FACTORS ON THE STATE OF GROUNDWATER OF KAZAKHSTAN**

**Abstract.** This article reviews the negative impact of anthropogenic changes on groundwater.

The main changes in physical and geographical conditions that occur under the impact of anthropogenic pressures and that have the most significant influence on the state of groundwater, as well as a negative impact on the conditions of the formation of groundwater are: changes in the landscape caused by agricultural works, mining, construction of settlements, etc.; changes in the hydrographic network caused the construction of hydroelectric power facilities; changes in the composition of the atmospheric air; changes in the groundwater level regime, climatic conditions. The most significant factor of change in groundwater formation conditions is the progressive anthropogenic pollution of groundwater. It negatively influences the number of resources and their quality.

**Key words:** Groundwater, anthropogenic changes, groundwater pollution.

**Introduction.** The features of climatic conditions have left their mark on the formation of the river network. The increasing anthropogenic impact on the environment results in quantitative and qualitative changes in the state of the environment, including changes in hydrogeological parameters of aquifers and aquifer systems.

Water resources of Kazakhstan have decreased by 20 km<sup>3</sup> per year over the past 50 years, and this process is going on. The decrease in water volumes is associated with global and regional climate changes, and most of all with increased water withdrawal from both groundwater resources and from transboundary rivers in neighboring countries. Large rivers flowing through our country's territory originate in neighboring countries. This led to the problems in the rational use of transit rivers and their ecological state.

The most significant factor that causes changes in the state of groundwater is progressive anthropogenic pollution. It does not directly affect the volume of resources but, in some cases, reduces the volume of available groundwater resources because water quality characteristics do not comply with sanitary norms [1,2]. For example, during exploitation of the Almaty groundwater deposit in the city of Almaty, as a result of pollution, aquifers lying at a depth of less than 150 m, according to the requirements of sanitary and epidemiological authorities, can only be used for technical purposes and are not suitable for drinking water supply.

Groundwater deposits in the city of Astana are not exploited due to progressive pollution [3]. In the Republic of Kazakhstan, there is groundwater pollution in Aktobe, Akmola, Almaty, East Kazakhstan, South Kazakhstan regions. It causes restriction of use and, consequently, reduction of operational groundwater reserves.

It was established that the biggest changes in the state of groundwater caused by anthropogenic factors occur in the industrial centers, urban agglomerations and in the ecological disaster zones in the Aral Sea region and at the Semipalatinsk nuclear test site.

**Methods.** A comprehensive analysis of hydrogeological materials on the territory of Kazakhstan was used as a research methodology to determine the negative impact of anthropogenic factors on the state of groundwater.

*Anthropogenic impact on landscapes.* The diversity of geological-geomorphological, climatic, soil and vegetation conditions of the territory of Kazakhstan determines the diversity of landscapes. As solar heat increases from the north to the south and precipitation decreases, there is a consecutive change of natural zones: forest-steppes, steppes, semi-deserts and deserts.

Technogenic impact on landscapes of Kazakhstan is quite significant. The change of landscapes results in overwetting of lands, swamping, oppression of natural vegetation and its replacement by hydromorphic species. The share of landscape areas in terms of the degree of anthropogenic impact is as follows: the areas of medium and strong disturbance are approximately equal and reach 42% in total; the areas of light disturbance make up 38%; the areas of very light and insignificant anthropogenic impact make up 20%.

According to the land balance data, as of November 1, 2017, there were 247.7 thousand hectares of disturbed lands in the Republic of Kazakhstan. There are quarries, overburden rocks and mining dumps, tailing dumps, ash dumps, oil fields and barns on these lands. In all industrial regions there are ecologically dangerous zones that have a negative impact: spoil tips, dumps, quarries, drilling wells, wastes of mining production; they occupy a total area of more than 60 thousand hectares and constantly pollute the soil [4].

Diverse anthropogenic impact on nature leads to significant changes in the natural zones. Agricultural production has the most significant impact on the natural territorial complexes of Kazakhstan. 85.3% of the land of the country is used for agricultural production; it significantly affects the landscape and ecological status of the land. An agrogenic impact, impact of reclamation and impact of pasture are the main agricultural impacts on landscapes. Steppe landscapes disappear; indigenous forest landscapes are replaced by derivatives; swamps are drained; deserts are irrigated, etc.

*Change in natural hydrogeological conditions.* An anthropogenic impact on groundwater has become particularly significant in this century due to the development and intensification of industry and agriculture, the growth of large cities and the expansion of urbanized areas. It manifests itself in the depletion of groundwater resources and deterioration of their quality.

The anthropogenic intervention in the natural groundwater regime has a significant impact on ecosystems. Intensifying anthropogenic pressure on groundwater resource potential leads to progressive deterioration of ecological and hydrogeological conditions in Kazakhstan. This is primarily associated with the depletion of groundwater resources, formation of cones of depression and water afflux zones, groundwater pollution, which significantly impacts the environment (including the geological environment) and human habitats. These negative changes happen with the most intensity in the areas of development of mining, oil and gas production and chemical industry [2,5].

Significant changes in natural hydrogeological conditions occur when groundwater is exploited for water supply, irrigation, watering of pastures. Aquifers are depleted, i.e. overlying and adjacent aquifers' groundwater reserves are exhausted; extensive cones of depression occur; hydrogeological conditions in oil and gas aquifers change during the development with maintenance of reservoir pressure, which contributes to the penetration of aggressive oil and gas fluids into the upper aquifers; groundwater and surface water are polluted; chemical composition of groundwater changes [11]. Thus, at the oil fields of the Yuzhno-Embinsky oil and gas production complex, about 18-20 million m<sup>3</sup> of produced water is extracted in the process; only about 30% of it is re-injected into the oil-bearing formations to maintain reservoir pressure; the remaining water is discharged into the nearby salinas.

Hydrogeological conditions significantly change on the irrigated lands: water and salt balance of the irrigated zone changes; there is an increase of groundwater level; groundwater is polluted with toxic fertilizers and chemicals, i.e. their hydrochemical regime changes; there is (widespread) soil salinization, which is the main scourge of irrigated agriculture and one of the important negative factors of impact on the geological environment.

*Influence of groundwater exploitation for various purposes (water supply, irrigation, watering of pastures, etc.).* Great changes in natural hydrogeological conditions of a particular area occur under the influence of groundwater exploitation for water supply, land irrigation and, considerably on a smaller scale, for watering of pastures.

All the negative processes manifested themselves particularly strongly at large exploited groundwater deposits used for the water supply of Almaty, Taraz, Shymkent, Kentau, Ust-Kamenogorsk, Semey, Kyzylorda, Baykonyr, Zhezkazgan and other cities (table 1) [6].

Table1 –Formation of cones of depression in the areas of large water intakes

Administrative regions	Settlements, districts	The maximum decrease in the groundwater level, m	The cone of depression's area, km <sup>2</sup>
West Kazakhstan			
Aktobe	Aktobe city	25-30	40-45
	Khromtau town	20-25	30-35
	Oil fields	120-170	7,000-9,000
Atyrau	Oilfields	130-200	22,000-24,000
West-Kazakhstan	Uralsk city	30-35	35-40
	Oil fields	100-150	5,000-6,000
Mangistau	Oil fields	130-190	10,000-12,000
North Kazakhstan			
Kostanay	Kostanay city	25-35	25-30
North-Kazakhstan	Petropavlovsk city	15-20	15-20
Akmola	Kokshetau city	15-20	20-25
Pavlodar	Pavlodar city	15-20	15-20
		50-60	70-80
Central Kazakhstan			
Karaganda	Karaganda city	60-120	80-200
	Zhezkazgan city	80-130	80-250
	Baikonyr city	40-60	50-70
	Shakhtinsk town	50-100	70-110
	Temirtau city	50-100	70-110
	Balkhash city	40-90	50-90
East Kazakhstan			
East-Kazakhstan	Ust-Kamenogorsk city Semey city	35-60	30-40
		15-20	25-30
		30-50	35-40
South Kazakhstan			
Almaty	Taldykorgan city	20-25	30-40
	Almaty city	20-40	140-150
	Talgar town	70-80	140-150
	Ushtobe town	30-35	40-50
	Dostyk railway station	30-40	60-70
Zhambyl	Taraz city	65-70	>100
	Karatau town	80-100	60-65
Turkestan	Turkestan city	10-15	15-20
	Shymkent city	25-30	110-120
	Kentau town	550	>1500
Kyzylorda	Kyzylorda city, East Sub-Aral area Oil fields	40-45	>90
		130-150	>25,000 3,000-5,000

Cones of depression with the area of 140-150 km<sup>2</sup> each occurred at the exploited Almaty and Talgar groundwater deposits (an alluvial fan).

A typical example of the influence of drainage of mine workings during long-term exploitation of solid mineral deposits is the Mirgalimsayskoye polymetallic deposit, which is karst carbonate rocks of the Karatau mountain range. For the 25-year period of industrial development of the deposit area, the total reduction of the level of fissure-karst water in the center of the minefield reached 550 m and a huge cone of depression with the area of more than 1500 km<sup>2</sup> occurred. The processes of intensive drainage of water-bearing limestone and drainage of the territory not only led to a radical change of the conditions for the formation of the regime of fissure-karst water but also caused a significant violation of the natural regime of almost all types of groundwater which are common in the deposit area.

*Fluctuations of groundwater levels.* Another type of anthropogenesis of the natural groundwater regime is the increase of its levels which is accompanied by flooding of various structures and which spreads on the larger area [7]. About 300 settlements in Kazakhstan are periodically hit by flooding to some extent. Among them, there are such large cities as Nur-Sultan, Almaty, Karaganda, Kokshetau, Atbasar, Shchuchinsk, Pavlodar, Atyrau and others [1,5,8,9].

1. Areas that are drained and heavily drained with terrain fragmentation of  $>50$  m and prevailing groundwater depth of more than 3-5 m, less frequently 10 m. These territories occupy 15-20% of the area of the Republic of Kazakhstan and are located mainly in the Central Kazakhstan Uplands, the Mugodzhars Hills and mountain systems of the orogenic belt of Eastern and South-Eastern Kazakhstan.

2. The edges of the main river basins of Kazakhstan represented by deltaic strata, floodplains of river valleys, numerous lake systems and water reservoirs are the complete opposite of intensively drained mountain and lowland areas. These areas are periodically flooded by river water during high water and flood periods. The groundwater depth is less than 2 m during most of the year. The drainage of these areas is extremely low - the depth of terrain fragmentation is usually less than 5 m.

3. Weakly and medium-drained areas with terrain fragmentation of  $<50$  m and with groundwater depth of 3-5 m have an intermediary position. Geomorphologically, these areas belong to the southwestern part of the Caspian Plain - its sandy plains, the Ural-Emba denudation plateau, the central part of the Mangistau Plain, the Karatau mountain range and the most part of the Mugodzhars area's uplands, the southern part of the Torgay table plain and the northern part of Aral Sea region, the eastern part of the Aral structural-denudation-accumulative plain, the denudation plain of the Kazakh Uplands, the northern and southern parts of the Shu-Sarysu denudation-accumulative plain; the western, southern and eastern parts of the Syrdarya accumulative plain and the most part of the Balkhash-Alakol Plain.

From the anthropocentric point of view, it is necessary to identify degrees of territorial disturbance of landscapes, ecosystems and their corresponding zones [10,11]:

- environmental well-being; in this case, the state of natural complexes is close to their natural functioning, ensuring traditional forms of economic activity without damage to the health of the population; these are lands of the first category;

- environmental risk; in this case, there is a fixed change in the natural properties of natural complexes which leads to negative consequences for nature and people; these are lands of the third category;

- environmental crisis; in this case, the change in the properties of natural complexes poses a threat to economic activity and people's health;

- environmental disaster; in this case, negative changes of natural complexes lead to disruption of the existing economic activity; to a significant increase in human morbidity; a serious system of measures is required to eliminate the damage;

- environmental catastrophe; in this case, negative changes of natural complexes lead to the impossibility to conduct traditional economic activity and human habitation; a vivid example is the environmental catastrophe of the Aral Sea which passed consistently through the environmental crisis and environmental disaster.

*Anthropogenic pollution of groundwater.* Groundwater in Kazakhstan experiences various hydrogeological conditions and suffer from severe anthropogenic impact. It is primarily manifested in the pollution of groundwater. The main sources of groundwater pollution are industrial wastes of mining complexes and oil and gas production complexes, agricultural facilities, cities and large settlements, large dumps of industrial, household and radioactive wastes, etc. The largest polluted sites are located near enterprises that discharge industrial wastes and sewage to the earth's surface or into the river network without preliminary treatment. In 2016 the total volume of sewage discharged into the river network was  $5.9 \text{ km}^3/\text{year}$ , including  $0.131 \text{ km}^3/\text{year}$  (2.25%) of untreated sewage [4]. Such facilities include the majority of enterprises of mining, processing, construction, livestock and transport industries, as well as urban agglomerations with an unreliable industrial and household sewage treatment system or without any system. For example, some water intakes used for domestic purposes in the cities of Aktobe, Temirtau, Karaganda, Shemonaikha and Ridder (Leninogorsk). Mining and industrial enterprises of Karaganda, East Kazakhstan and Aktobe regions have the greatest impact on groundwater.

In recent years, the number of identified and potential sources of pollution has remained almost unchanged. The reasons include the economic downturn in the country, the decrease in the growth of

industrial and agricultural production and the associated decrease in the volume of pollutants and in the volume of wastewater. At the same time, there is an increase in the pollution level of water bodies by the number of ingredients, which is probably due to an increase in the inflow of scattered pollution sources into water bodies with surface runoff caused by the lack of systematic, targeted work to eliminate such pollution sources. Intensive development of mining and processing of minerals resulted in the fact that the basis of modern industry in the country is formed by the most environmentally hazardous enterprises in metallurgy, fuel and energy and mining industries. They make up 88.5% of all emissions to the environment. In Kazakhstan, the largest sites of polluted groundwater are within the Karaganda, Pavlodar-Yekibastuz, Rudno-Altyi, Kostanay and Karatau (South Kazakhstan) mining complexes, as well as in Almaty and Semipalatinsk regions.

Based on the results of the monitoring, in the area of large cities, the sites with polluted groundwater were discovered in the zone of influence of individual water intakes. Large sites with polluted groundwater are located near these water intakes, which leads to a failure of entire groundwater intakes or their sections. Withdrawal of water for domestic purposes is stopped at the sites with polluted groundwater of Aktobe, Ust-Kamenogorsk and Karaganda cities.

The main criteria of natural water's quality by hydrochemical indicators are values of Maximum Permissible Concentrations (MPC) of pollutants. It is valid for water sources used for domestic purposes, for utilities and for the fishing industry.

According to the data of the Groundwater Monitoring Service, more than 1100 potential sources of groundwater pollution are detected on the territory of the Republic of Kazakhstan. 350 of them directly impact the hydrogeochemical state of groundwater. The greatest number of sources of pollution were found in Pavlodar region (255 sources), Karaganda region (210), East Kazakhstan region (117), Akmola region (103) and Almaty region (103) (table 2). These are the most environmentally unfavorable regions of Kazakhstan in terms of pollution levels. One should consider the ecological status of groundwater in the administrative regions of Kazakhstan [6].

Table2 – Distribution of sources and sites of groundwater pollution by the administrative regions of the Republic of Kazakhstan and the availability of the monitoring network as of January 1, 2016

Administrative region	Number of potential sources of groundwater pollution	Number of detected sites with groundwater pollution		
		total	Were inspected in 2015	Have the monitoring network
Akmola	103	6	5	6
3 areas in Akmola region	40	10	8	10
Aktobe	37	11	11	11
Almaty	103	10	10	10
Atyrau	11	5	5	10
Semipalatinsk area, East-Kazakhstan region	100	6	6	6
Ust-Kamenogorsk area, East-Kazakhstan region	17	13	13	13
Zhambyl	19	16	15	16
West-Kazakhstan	38	10	10	10
Karaganda	210	62	31	31
Kyzylorda	11	3	2	2
Kostanay	70	5	5	5
Mangistau	23	17	15	15
Pavlodar	255	22	22	22
North-Kazakhstan	47	1	1	4
Turkestan	29	17	3	17
Total in the Republic of Kazakhstan:	1113	214	162	188

Among the total number of monitored polluted sites, the majority of sites (250) are characterized by increased mineralization, the hardness of water; by sulfate and chloride content exceeding the MPC. About 87 sites are characterized by an increased content of nitrous compounds in groundwater, 52 sites - by an increased content of oil products, 63 sites - by an increased content of heavy metals, 45 sites - by an increased content of phenols, 92 sites - by an increased content of inorganic compounds and 30 sites - by an increased content of organic compounds.

By hazard class of detected pollutants, 114 monitored sites have moderately hazardous groundwater pollution, 51 sites have hazardous pollution, 34 sites have highly hazardous pollution and 15 sites have extremely hazardous class.

At 151 deposits and 44 intakes of groundwater used for domestic purposes, pollution of various classes is detected. In most cases, the pollution is associated with anthropization. Moderately hazardous pollution is detected at 64% of deposits, hazardous pollution - at 19% of deposits, extremely hazardous pollution - at 17% of deposits. The highest percentage of deposits with extremely hazardous pollution is in Karaganda region (44%), and in total, with hazardous pollution, it makes up half (50%) of all polluted groundwater deposits of the region. In East Kazakhstan region 72% of polluted deposits have hazardous and extremely hazardous pollution.

In Kazakhstan, there is the areal pollution of groundwater by oil products in the territories of almost all oil and gas production complexes. In addition, the pollution of groundwater by radionuclides is detected at oil production sites. The main sites of technogenic radioactive pollution of groundwater are at the Semipalatinsk nuclear test site and in the zone of its influence; in the places where peaceful nuclear explosions were conducted (including the so-called «Azgir trace» in the northern part of the Caspian Sea region); in the areas of radioactive waste burial and storage (especially in the territories of Kokshetausky, Kengir-Akbakaysky, and Chiganak-Aksuyeksky mining complexes); in the areas of currently developed uranium deposits, especially in the areas of the deposits which are developed by the method of underground leaching (in the Shu-Saryusky mining complex where uranium deposits of Uvanas, Kanzhugan, Mynkuduk, and Moinkum are being developed).

**Results.** When conducting the research, the following main results were obtained:

1. The negative impact of anthropogenic factors on the state of groundwater in Kazakhstan is confined to industrial centers, urban agglomerations and environmental disaster zones in the Aral Sea region and at the Semipalatinsk nuclear test site.

2. Significant changes in the state of groundwater are associated with the anthropogenic impact on the regime of surface runoff due to its regulation in the river basins.

3. Important factors that change the state of groundwater in Kazakhstan include changes in the temperature regime of the territory and anthropogenic pollution of groundwater.

4. Changes in natural conditions under the influence of anthropogenic pressures cause a trend towards an overall reduction in available water resources.

5. A reduction in groundwater reserves of drinking water caused by progressive groundwater pollution of exploited aquifers is forecast in Kazakhstan.

**С. В. Осипов<sup>1</sup>, А. М. Ерменбай<sup>1</sup>, А. Ж. Ақылбекова<sup>1</sup>, Ю. Н. Ливинский<sup>1</sup>, Ойторе Анарбеков<sup>2</sup>**

<sup>1</sup>Satbayev University, Ахмедсафин атындағы гидрогеология және геоэкология институты, Алматы, Қазақстан;

<sup>2</sup>IWMI-Орталық Азия, Ташкент, Өзбекстан

#### **АНТРОПОГЕНДІК ФАКТОРЛАРДЫҢ ҚАЗАҚСТАНДАҒЫ ЖЕР АСТЫ СУЛАРЫНЫҢ ЖАҒДАЙЫНА ТЕРІС ӘСЕРІ**

**Аннотация.** Қоршаған ортаға антропогендік әсердің ұлғайуына байланысты оның күйінде сандық және сапалық өзгерістер, соның ішінде сулы қабаттар мен кешендердің гидрогеологиялық параметрлері болады. Антропогендік қысымдардың әсерінен пайда болатын және жер асты суларына, соның ішінде олардың қалыптасуына теріс әсер ететін физикалық-географиялық жағдайлардың негізгі өзгерістері: ауылшаруашылық жұмыстары, тау-кен жұмыстары, елді мекендер салу және т. б жағдайларда жергілікті ландшафтардың өзгеруі; гидроэнергетикалық объектілерді салу нәтижесінде гидрографиялық желінің өзгеруі; атмосфералық

ауа құрамының өзгеруі, жер асты суларының деңгей режимінің өзгеруі, климаттық жағдайлардың өзгеруі. Жер асты суларының қалыптасу жағдайларының өзгеруінің, олардың ресурстары мен сапасына теріс әсер ететін маңызды факторы, жер асты суларының прогрессивті антропогендік ластануы болып табылады.

Жер үсті ағындарын антропогендік реттеудің әсері жер асты сулары ресурстарына айтарлықтай әсер етеді. Бір жағынан өзендерде резервуарларды құру су қоймасына іргелес жатқан аңғарлардың аллювиалды шөгінділерінде жер асты суларының ресурстарын көбейтеді, екінші жағынан, резервуарларды құру кезінде жер асты суларының жиналуы жер асты суларының деңгейінің жоғарылауына және су қоймаларының жағалауларында жер асты суларының тайыз пайда болуымен олардың бетінен буланудың жоғарылауына әкеледі, бұл жер асты сулары ресурстарының көлемін азайтады.

Жер асты суларының күйін өзгертудің маңызды факторы прогрессивті антропогендік ластану болып табылады, ол ресурстардың көлеміне тікелей әсер етпейді, бірақ кейбір жағдайларда судың сапалық сипаттамаларының санитарлық нормаларға сәйкес келмеуіне байланысты пайдалануға болатын жер асты суларының мөлшерін азайтады.

Қазақстан Республикасының аумағында яғни Ақтөбе, Ақмола, Алматы, Шығыс Қазақстан және Оңтүстік Қазақстан облыстарында пайдалану шектелуіне, демек, жер асты суларының пайдалану қорларының азаюына әкелетін жер асты суларының ластануы байқалады.

Қазақстан аумағының геологиялық, геоморфологиялық, климаттық және топырақ-өсімдік жағдайларының алуан түрлілігі ландшафттардың алуан түрлілігін анықтайды. Күн жылуы солтүстіктен оңтүстікке қарай көтеріліп, жауын-шашын азая бастаған сайын табиғи зоналарда тұрақты түрде өзгеріс болады: орманды дала, дала, шөлейт және шөл.

Қазақстанның ландшафттарына техногендік әсер айтарлықтай. Ландшафттардың өзгеруі жерлердің тым көп түсуінен, олардың батпақтануынан, табиғи өсімдіктердің өсуінен және оның гидроморфты түрлермен алмастырылуынан көрінеді.

Табиғатқа жан-жақты антропогендік әсер табиғи аймақтардың пайда болуына айтарлықтай өзгерістер әкеледі. Ауылшаруашылық өндірісі - бұл Қазақстанның табиғи-аумақтық кешендеріне әсер етудің негізгі түрі, ол жердің ландшафттық-экологиялық жағдайына айтарлықтай әсер етеді, ол елдің 85,3% құрайды. Ландшафттарға ауылшаруашылық әсерінің негізгі түрлері агрогендік, мелиоративті және жайылымдық болып табылады. Дала ландшафттары жоғалады, жергілікті орман ландшафттары туындыларға ауыстырылады, батпақты жерлер құрғап, шөлдер суарылады және т.б.

Жер асты суларының табиғи режиміне антропогендік араласу экожүйелердің күйіне айтарлықтай әсер етеді. Жер асты суларының ресурстық әлеуетіне техногендік жүктемелердің күшеюі Қазақстандағы экологиялық және гидрогеологиялық жағдайлардың біртіндеп нашарлауына әкеледі. Бұл, ең алдымен, жер асты сулары ресурстарының сарқылуымен, депрессиялық шұңқырлардың және судың су астындағы аймақтарының пайда болуымен, жер асты суларының ластануымен, табиғи ортаға (геологиялықты қоса алғанда) және адам қоршаған ортасына айтарлықтай әсер етеді.

Соңғы жылдары ластанудың анықталған және ықтимал көздерінің саны іс жүзінде өзгеріссіз қалды, бұл республикадағы экономикалық құлдырауға, өнеркәсіптік және ауылшаруашылық өндірістің өсуінің төмендеуіне, сондай-ақ осы процестермен байланысты ластанушы заттар мен сарқынды сулардың төгілуінің төмендеуіне байланысты. Сонымен қатар, су айдындарының ластану деңгейінің бірқатар ингредиенттер бойынша жоғарылауы байқалады, мүмкін мұндай ошақтарды залалсыздандыру бойынша жүйелі, мақсатты жұмыстардың болмауынан судың ағып кетуі бар су объектілеріне ластанудың таралған көздерін таратудың ұлғаюы.

Зерттеу әдісінің әдістемесі ретінде жер асты суларына антропогендік экологиялық өзгерістердің әсерін анықтау үшін Қазақстан аумағындағы гидрогеологиялық материалдарға кешенді талдау жасау қолданылды.

**Түйін сөздер:** Жер асты сулары, антропогендік өзгерістер, жер асты суларының ластануы.

**С. В. Осипов<sup>1</sup>, А. М. Ерменбай<sup>1</sup>, А. Ж. Ақылбекова<sup>1</sup>, Ю. Н. Ливинский<sup>1</sup>, Ойторе Анарбеков<sup>2</sup>**

<sup>1</sup>Satbayev University, Институт гидрогеологии и геоэкологии им. Ахмедсафина, Алматы, Казахстан;

<sup>2</sup>ИВМИ-Центральная Азия, Ташкент, Узбекистан

## **НЕГАТИВНОЕ ВОЗДЕЙСТВИЕ АНТРОПОГЕННЫХ ФАКТОРОВ НА СОСТОЯНИЕ ПОДЗЕМНЫХ ВОД КАЗАХСТАНА**

**Аннотация.** Вследствие всевозрастающего антропогенного воздействия на окружающую среду в ее состоянии происходят количественные и качественные изменения, в том числе гидрогеологических параметров водоносных горизонтов и комплексов. Основными изменениями физико-географических условий, происходящими под воздействием антропогенных нагрузок и наиболее сильно влияющими на состояние

подземных вод, а также оказывающими негативное воздействие на условия их формирования, являются: изменение ландшафта местности при сельхозработках, разработке полезных ископаемых, строительстве населенных пунктов и др.; изменение гидрографической сети в результате строительства объектов гидроэнергетики; изменение состава атмосферного воздуха, уровня режима подземных вод, климатических условий. Наиболее значимым фактором изменения условий формирования подземных вод, отрицательно влияющим на величину их ресурсов и качество, является прогрессирующее антропогенное загрязнение подземных вод.

Влияние антропогенного регулирования поверхностного стока в значительной степени влияет на ресурсы подземных вод. С одной стороны, создание водохранилищ на реках увеличивает ресурсы подземных вод в аллювиальных отложениях долин, примыкающих к водохранилищу, а с другой стороны – подпор подземных вод при создании водохранилищ вызывает повышение уровня подземных вод и увеличение испарения с их поверхности при неглубоком залегании подземных вод по берегам водохранилищ, что уменьшает объем ресурсов подземных вод.

Наиболее значительным фактором изменения состояния подземных вод является прогрессирующее антропогенное загрязнение, не влияющее непосредственно на объем ресурсов, но, в ряде случаев, сокращающее объем доступных для использования ресурсов подземных вод из-за несоответствия качественных характеристик воды санитарным нормам.

На территории Республики Казахстан загрязнение подземных вод, вызывающее ограничение использования и, следовательно, уменьшение эксплуатационных запасов подземных вод, отмечается в Актюбинской, Акмолинской, Алматинской, Восточно-Казахстанской, Южно-Казахстанской областях.

Разнообразие геолого-геоморфологических, климатических и почвенно-растительных условий территории Казахстана обуславливает многообразие ландшафтов. По мере увеличения солнечного тепла с севера на юг и уменьшения осадков происходит последовательная смена природных зон: лесостепи, степи, полупустыни и пустыни.

Техногенное воздействие на ландшафты Казахстана довольно значительное. Изменение ландшафтов выражается в переувлажнении земель, их заболачивании, угнетении естественной растительности и замещении её гидроморфными видами.

Разностороннее антропогенное воздействие на природу приводит к существенным изменениям облика природных зон. Сельскохозяйственное производство является основным видом воздействия на природно-территориальные комплексы Казахстана, оно существенно влияет на ландшафтно-экологическое состояние земель, охватывая 85,3% земель страны. Основными видами сельскохозяйственного воздействия на ландшафты являются агрогенный, мелиоративный и пастбищный. Исчезают ландшафты степей, коренные лесные ландшафты заменяются производными, осушаются болота, орошаются пустыни и так далее.

Антропогенное вмешательство в естественный режим подземных вод оказывает существенное влияние на состояние экосистем. Интенсификация техногенной нагрузки на ресурсный потенциал подземных вод ведёт к прогрессирующему ухудшению эколого-гидрогеологических условий в Казахстане. Это связано, прежде всего, с истощением ресурсов подземных вод, образованием депрессионных воронок и зон подпора вод, загрязнением подземных вод, существенно влияющим на окружающую природную среду (в том числе на геологическую) и среду обитания человека.

В последние годы количество выявленных и потенциальных источников загрязнения остается практически неизменным, что обусловлено экономическим спадом в республике, снижением роста промышленного и сельскохозяйственного производства и связанным с этими процессами снижением сброса массы загрязняющих веществ и объемов сточных вод. Вместе с тем, наблюдается рост уровня загрязненности водных объектов по ряду ингредиентов, что, вероятно, обусловлено ростом поступления в водные объекты с поверхностным стоком рассеянных источников загрязнения в связи с отсутствием планомерных, целенаправленных работ по нейтрализации таких очагов.

В качестве методологии исследований использовался комплексный анализ гидрогеологических материалов по территории Казахстана с целью определения влияния антропогенных изменений окружающей среды на подземные воды.

**Ключевые слова:** подземные воды, антропогенные изменения, загрязнение подземных вод.

#### **Information about authors:**

Osipov S.V., Leading Researcher, Head of the Laboratory of groundwater resources, candidate of geological and mineralogical sciences, Satbayev University, Ahmadsafin Institute of Hydrogeology and Environmental Geoscience, Almaty, Kazakhstan; osvovs@rambler.ru; <http://orcid.org/0000-0002-2935-5046>

Ermenbay A.M., Researcher, Satbayev University, Ahmadsafin Institute of Hydrogeology and Environmental Geoscience, Almaty, Kazakhstan; [ms.ermenbay@mail.ru](mailto:ms.ermenbay@mail.ru); <http://orcid.org/0000-0002-1751-0280>

Akylbekova A.Zh., Scientific secretary, Satbayev University, Ahmetsafin Institute of Hydrogeology and Environmental Geoscience, Almaty, Kazakhstan; aigul\_igg@mail.ru; <https://orcid.org/0000-0002-1055-1987>

Livinsky Yu.N., Leading Researcher, candidate of geological and mineralogical sciences, Satbayev University, Ahmetsafin Institute of Hydrogeology and Environmental Geoscience, Almaty, Kazakhstan; livinskii\_yur@mail.ru; <https://orcid.org/0000-0002-1268-6914>

Anarbekov Oytur, Researcher, Acting Country Manager, Regional Office of International Water Management Institute for Central Asia, Tashkent, Uzbekistan; anarbekov@yahoo.com; <https://orcid.org/0000-0003-0622-5940>

## REFERENCES

[1] Osipov S.V., Livinsky Yu.N., Yermenbai A.M. Influence of anthropogenic environmental changes on the groundwater formation in Kazakhstan // XIX International Multidisciplinary Scientific GeoConference SGEM 2019. Albena. Vol. 19. P. 337-342. ISBN978-619-7408-77-5. ISSN 1314-2704. doi: 10.5593/sgem2019/1.2 (in Eng.). Issue 2.2.

[2] Absametov M.K., Adenova D.K., Nusupova A.B. Assessment of the impact of antropogenic factors water resources of Kazakhstan //News of the National Academy of Sciences of the Republic of Kazakhstan. Series of geology and technical sciences. Almaty, 2019. Vol. 1. N 433 (2019). P. 248-254. ISSN 2518-170X (Online). ISSN 2224-5278(Print). Scopus, IF 0.067. <https://doi.org/10.32014/2019.2518-170X.30>

[3] Absametov M.K., Osipov S.V., Livinsky Yu.N., Murtazin Ye.Zh., Yermenbai A.M. Identification of prospective areas and assessment of groundwater resources of North and Central Kazakhstan for water supply of settlements. Almaty. P. 2017-277.

[4] National report on the environmental condition and on the use of natural resources for 2015. <http://www.ecodoklad.kz>

[5] Murtazin E., Miroshnichenko O., Trushel L. Structure of geoinformational and analytical system “groundwater resources and reserves of the republic of Kazakhstan” // News of the Academy of sciences of the Republic Kazakhstan. Series of geology and technical sciences. 2019. Vol. 3. N 435 (2019), P. 21-29. ISSN 2518-170X (Online), ISSN 2224-5278 (Print). (2019), Scopus, IF 0.067. <https://doi.org/10.32014/2019.2518-170X.63>

[6] Smolyar V.A., Burov B.V., Veselov V.V. and others. Water resources of Kazakhstan (surface and underground waters, current state). Directory. Almaty: Research Center “Gylym”, 2002. P. 499-566.

[7] Mustafayev S.T., Smolyar V.A., Burov B.V. Hazardous geological processes in the territory of South-East Kazakhstan. Almaty: Research Center “Gylym”. 2008. 258 p.

[8] Osipov S.V., Livinsky Yu.N., Yermenbay A.M., Gafurov Zafar. Change of formation conditions of groundwater of Kazakhstan under the influence of anthropogenic changes of the environment // News of National Academy of Sciences. Series of Geology and Technical Sciences, 2019. Vol. 3. N 435 (2019). P. 36-41. ISSN 2518-170X (Online), ISSN 2224-5278 (Print). (2019), Scopus, IF 0.067. <https://doi.org/10.32014/2019.2518-170X.65>

[9] Smolyar V.A. The impact of changes in the hydrogeodynamic regime of groundwater on the environment. Geology and subsurface protection. Almaty: KazGEO, 2017. N 1 (62). P. 54-62.

[10] Environmental dictionary, 2001. <http://www.ecosystema.ru>

[11] Onlasynov Zh., Akylbekova A., Sotnikov E., Rakhimov T., Kanafin K., Balla Dagmar. Implementation of the ersforyield analyzing of irrigated lands of South Kazakhstan // News of National Academy of Sciences. Series of Geology and Technical Sciences, Almaty, 2019. Vol. 4, N 436 (2019). P. 113-120. ISSN: 2224-5278 (Print). ISSN: 2518-170X (Online) Scopus, IF 0.067. <https://doi.org/10.32014/2019.2518-170X.104>

**NEWS**

OF THE NATIONAL ACADEMY OF SCIENCES OF THE REPUBLIC OF KAZAKHSTAN

**SERIES OF GEOLOGY AND TECHNICAL SCIENCES**

ISSN 2224-5278

Volume 2, Number 440 (2020), 141 – 147

<https://doi.org/10.32014/2020.2518-170X.41>

UDC 622.276.4; 622.276.6

**S. R. Rasulov<sup>1</sup>, G. T. Hasanov<sup>1</sup>, A. N. Zeynalov<sup>2</sup>**<sup>1</sup>Azerbaijan State Oil and Industry University, Baku, Azerbaijan Republic;<sup>2</sup>SRI “Geotechnical problems of oil, gas and chemistry”, Baku, Azerbaijan Republic.

E-mail: rasulovsakit@gmail.com

**ACOUSTIC TESTING OF RHEOLOGICAL PROPERTIES  
OF OIL IN BOREHOLE**

**Abstract.** The article considers the pulsed wave effect as more efficient and environmentally expedient in comparison with other influence methods. The effectiveness of the applied acoustic wave significantly depends on the correct choice of the mathematical model, taking into account the basic physical processes. When setting up mathematical model for removal of sand plug in bottom hole zone by acoustic influence it is necessary to consider variation of rheological parameters of oil versus depth. Physically, it means that it is necessary to study propagation of acoustic waves in non-homogeneous medium, as rheological parameters of fluid vary with depth. The problem in this statement has not been solved yet.

It was determined that particles of solids remaining in the well in suspension are in the gravitational field of the Earth and therefore, they are subject to the Boltzmann distribution over the depth of the well. In this case, the model proposed by Einstein for determining the viscosity of two-phase systems was used. The volume viscosity of oil changes when there is a particle of solids in it.

The dependence of changes in the rheological parameters of oil from the depth of the well mathematically comes down to solving the inverse problem for the equation proposed by Landau-Livshits. The inverse problem is to determine the desired value from the solution of the above equation with known information about the change in the acoustic waves of the front in time in two sections of the well.

Applying the Landau-Livshits model on the propagation of acoustic waves in a homogeneous fluid, a mathematical model of the propagation of acoustic waves in a heterogeneous fluid in oil wells is developed, where the rheological parameters of the fluid are subject to change at the changing of depth of borehole.

The hydrostatic pressure measurements in three drilling wells by depth gauges have shown that the deviation of the measured value of the hydrostatic pressure from the calculated to the depth of 2000-2500 m occurs according to linear law, after which there is a nonlinear law.

Based on the conducted researches of the diagnosis of rheological parameters of the fluid in the well, a graphical dependence of the change in relative density of oil on the depth of the well is constructed.

**Key words:** acoustic testing, rheology, oil, well, sand plug, acoustic waves, mathematical model.

**Problem statement.** Analysis of complications and emergency situations taking place while drilling and development of oil fields displays that many of them is related to variation of rheological parameters of oil [1,9]. Therefore, for the last years in order to avoid complications in production process, in particular to cleaning of bottom hole area from sand plug, the possibility of physical fields such as magnetic field, acoustic impact and others application is discussed in periodical press [1, 10-13]. We consider that pulsed wave effect is more efficient and environmentally appropriate for removal of sand plug from bottom hole area (the height of which constitutes 660000m each year) [14-16]. It is explained by exhaustion of layers in mature fields of Azerbaijan and due to this sand plug removal by traditional tools is not possible. That is why the repair works capacity each year involves over 100000 wells. The efficiency of applied acoustic wave field significantly depends on the correct choice of mathematical model taking into account the major physical processes.

When designing mathematical model of sand plug removal in bottom hole zone by use of acoustic effect the rheological parameters of oil variation versus depth must be taken into account. Physically this means the necessity to study propagation of acoustic waves in in homogeneous environment.

Therefore, the problem of bottom hole zone cleaning from sand plug by acoustic effect mathematically is reduced to resolution of equation of acoustic wave propagation in in homogeneous environment. It should be noted that the problem in such statement has not been solved.

**Problem resolution.** Various mathematical models are designed to describe acoustic waves propagation in the real fluid. For this case the Landau-Lipschitz model [1] is considered as appropriate:

$$\frac{\partial P}{\partial x} = -\frac{1}{c} \frac{\partial P}{\partial t} + a(x) \frac{\partial^2 P}{\partial t^2}$$

$$a(x) = \frac{1}{2\rho c^3} \left[ \left( \xi + \frac{4}{3}\eta \right) + k \left( \frac{1}{c_v} - \frac{1}{c_p} \right) \right] \quad (1)$$

where  $c$  – is acoustic wave propagation velocity;  $P$  – is field of acoustic pressure;  $\eta$  – is shearing viscosity;  $\xi$  – is bulk viscosity;  $\rho$  – is fluid density;  $c_p$  and  $c_v$  – are fluid heat absorption capacity at the constant pressure and capacity, respectively.

If acoustic pressure field is known, then from (1) we define the required value  $a(x)$ :

$$a(x) = \left( \frac{\partial P}{\partial x} + \frac{1}{c} \cdot \frac{\partial P}{\partial t} \right) \cdot \left( \frac{\partial^2 P}{\partial t^2} \right)^{-1} \quad (2)$$

In cases of unknown acoustic pressure field, it is required to derive the required  $a(x)$  from resolution of equation (1).

Therefore, variation of rheological parameters of oil versus well depth is mathematically reduced to resolution of reverse problem for equation (1). The reverse problem consists in defining of  $a(x)$  from solution of equation (1) in case of known variation of acoustic wave front in time at two sections of well.

Due to this the initial and boundary conditions are given as the following:

$$P(x, 0) = 0, \quad \frac{\partial P}{\partial t}(x, 0) = 0, \quad P(0, t) = \Phi(t), \quad P(\ell, t) = \varphi(t) \quad (3)$$

Resolving differential equation (1) applying Laplace transformation, we will have:

$$\frac{d\tilde{P}}{dx} = \left[ -\frac{s}{c} + s^2 a(x) \right] \tilde{P}; \quad \tilde{P}(x, s) = \int_0^\infty P(x, t) e^{-st} dt \quad (4)$$

Applied conditions in (3) will be as the following:

$$\tilde{P}(0, s) = \tilde{\Phi}(s) = \int_0^\infty \Phi(t) e^{-st} dt; \quad \tilde{P}(\ell, s) = \tilde{\varphi}(s) = \int_0^\infty \varphi(t) e^{-st} dt \quad (5)$$

In the process of acoustic waves propagation in the fluid the compression and dilation of fluid takes place causing the second viscosity  $\xi$ , named as bulk viscosity.

Oil viscosity is evaluated according to data of testing of samples acquired at the output from well. These data on oil viscosity and rheological parameters in general do not correspond to parameters under real conditions.

The particles of solid bodies incoming from layer into the well are brought to the surface not in a whole amount. Particles of solid bodies left in well in suspended form are unevenly distributed along the hole depth. Their amount is maximal in bottom hole while it decreases towards well mouth. It can be regarded that solid body particles suspended in the well are the subject of Boltzmann distribution. If to match the origin of coordinates to the well mouth, then:

$$n = n_0 \exp(kx), \quad \rho(x) = \rho_0 \exp(kx) \quad (6)$$

The viscosity coefficient for such two-phased fluids as crude oil can not be defined by the method applied for homogeneous fluids. Several rheological models exist for description of internal friction of oil. In case under the study it would be appropriate to use the model offered by Einstein for evaluation of viscosity of two-phase flow [17, 18]:

$$\eta = \eta_0(1 + 2,5n) \quad (7)$$

where  $\eta_0$  – is viscosity of pure fluid;  $n$  – is ratio of particles of hard bodies volume to total volume of fluid in the well.

Taking into account formula (6), the formula (7) is written as below

$$\eta = \eta_0 \left(1 + 2,5n_0 e^{kx}\right) \quad (8)$$

Similar to shear viscosity the bulk viscosity  $\xi$  of oil varies in case of solid body particles presence. Variation of bulk viscosity due to the presence of particles of solid bodies is calculated by Brenner [3] and is in the form shown below:

$$\xi = \xi_0 \left[ 1 + n_0 \left( 1 + \frac{4}{3} \cdot \frac{\eta_0}{\xi_0} \right) e^{kx} \right] \quad (9)$$

The constant coefficient « $k$ » in formulae (6), (8) and (9) characterizes variation degree of  $\rho$ ,  $\eta$ ,  $\xi$  from point to point versus variation of well depth and is a measure of diagnosis. It must be noted that for fluids  $c_p \approx c_v$  and therefore

$$a(x) = \frac{1}{2\rho c^3} \left( \xi + \frac{4}{3} \cdot \eta \right) = \alpha_0 \cdot e^{kx} + \beta_0 \quad (10)$$

$$\alpha_0 = \frac{1}{2\rho_0 c^3} \left( \xi_0 + \frac{4}{3} \cdot \eta_0 \right); \quad \beta_0 = \frac{1}{2\rho_0 c^3} \left[ \xi_0 n_0 \left( 1 + \frac{4}{3} \cdot \frac{\eta_0}{\xi_0} \right) + \frac{4}{3} \cdot \eta_0 \cdot 2,5n_0 \right]$$

Resolution of equation (4) while boundary conditions (5) is as the following:

$$\tilde{\varphi}(s) = \tilde{\Phi}(s) \exp \left\{ -\frac{s}{c} \ell + s^2 \left[ \beta_0 \ell + \frac{\alpha_0}{k} (1 - e^{-k\ell}) \right] \right\} \quad (11)$$

To define « $k$ » from equation (11) we apply the method of determined moments. For this, we expand the functions  $\tilde{\varphi}(s)$  and  $\tilde{\Phi}(s)$  in series by degrees of  $s$ , i.e.:

$$\tilde{\varphi}(s) = \phi_0 + s\phi_1 + s^2\phi_2 + \dots; \quad \tilde{\Phi}(s) = \Phi_0 + s\Phi_1 + s^2\Phi_2 + \dots \quad (12)$$

While  $\phi_n$  and  $\Phi_n$  are derived from the following:

$$\phi_n = \int_0^\infty \left[ \phi_n(\tau) - \phi_\infty \right] \frac{\tau^n}{n!} d\tau; \quad \Phi_n = \int_0^\infty \left[ \Phi_n(\tau) - \Phi_\infty \right] \frac{\tau^n}{n!} d\tau \quad (13)$$

Substituting (12) in (11) to define « $k$ » by diagnostic measure we derive transcendental equation:

$$\frac{\alpha_0}{k} (1 - e^{-k\ell}) = \frac{\phi_2}{\Phi_0} - \frac{1}{2} \left( \frac{\Phi_1}{\Phi_0} - \frac{\phi_1}{\Phi_0} \right)^2 + \frac{\Phi_1}{\Phi_0} \left( \frac{\Phi_1}{\Phi_0} - \frac{\phi_1}{\Phi_0} \right) - \frac{\Phi_2}{\Phi_0} - \beta_0 \ell \quad (14)$$

Taking into account that  $k\ell < 1$ , expand  $\exp(-k\ell)$  in series and we are restricted by initial three expansion terms. While doing this we have:

$$k = \frac{2}{\ell} \left\{ 1 - \frac{1}{\alpha_0 \ell} \left[ \frac{\phi_2}{\Phi_0} - \frac{1}{2} \left( \frac{\Phi_1 - \phi_1}{\Phi_0 - \Phi_0} \right)^2 + \frac{\Phi_1}{\Phi_0} \left( \frac{\Phi_1 - \phi_1}{\Phi_0 - \Phi_0} \right) - \frac{\Phi_2}{\Phi_0} - \beta \ell \right] \right\} \quad (15)$$

At present it is considered as complicated to hold direct experiments to study acoustic wave front variation versus time in two deep oil wells. Due to this we have limited our studies by indirect, experimental data evidencing necessity to test rheological parameters of oil along well depth.

The oscillogram of acoustic wave front for two oil samples acquired from various depths of active wells in “Neft dashlary” field is shown in figure 1.

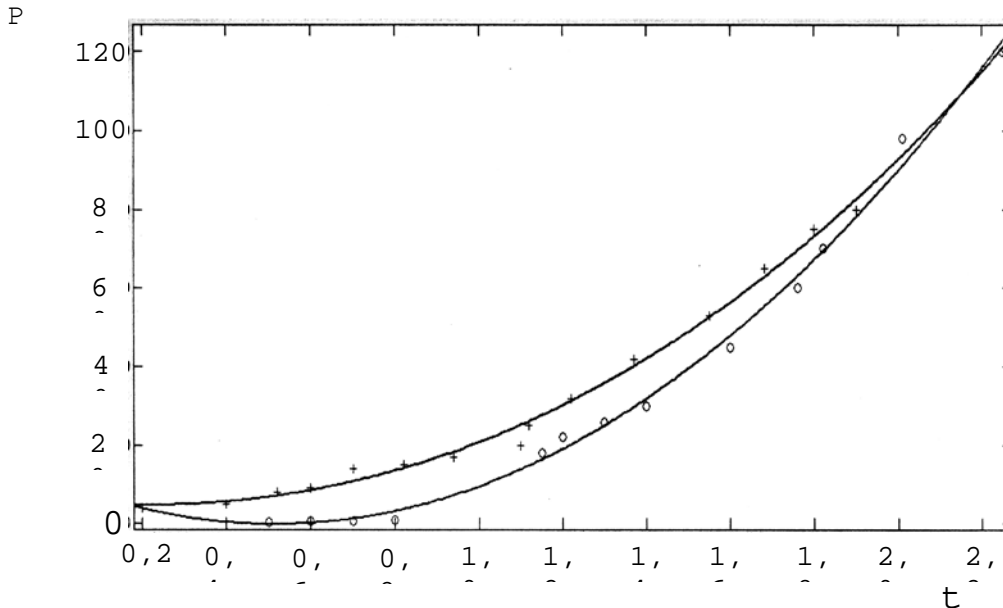

Figure 1 – Acoustic wave variation versus time

Computer processing of testing data displayed that these curves can be described by formulae below:

$$\Phi(t) = A_1 t \exp(-B_1 t^2), \quad \varphi(t) = A_2 t \exp(-B_2 t^2) \quad (16)$$

Rheological parameters of studied oil samples, according to laboratory testing were as the following:  $\rho_o = 780 \text{ kg/m}^3$ ,  $\eta_o = 0,002 \text{ Pa}\cdot\text{c}$ ,  $\rho_o = 820 \text{ kg/m}^3$ ,  $\eta_o = 0.003 \text{ Pa}\cdot\text{c}$ . Bulk viscosity value  $\xi_o$  has been evaluated as equal to the shear viscosity  $\eta_o$ .

Oil samples were acquired from the depths 2200 m and 3500 m. Computing solution of equation (14) taking into account processing results of tests [19] according to “MATLAB” software allowed us to define the average value of  $k = 1.25 \cdot 10^{-4} \text{ m}^{-1}$ .

To define the degree of correspondence of calculated value of «k» to reality we have measured in-situ the hydrostatic pressure by depth gauge while drilling of oil well in “Neft Dashlary” field.

Hydrostatic pressure measured by depth gauge in three wells displayed that down to 900-1000 m depths the hydrostatic pressure values are approximately coincide with those calculated according to formula  $P = \rho_o g H$ , where  $\rho_o$  – is the density of drilling mud at output.

At depths below than 900-1000 m the discrepancy is observed between calculated and measured values of hydrostatic pressure. Processing of hydrostatic pressure values measured down to 2000-2500 m depths showed that measured hydrostatic pressure value can be accurately defined by the formula below [20]:

$$P = \rho_o g H (1 + k H) = P_o (1 + k H) \quad (17)$$

where  $g$  - is acceleration of free pressure,  $k \approx 2 \cdot 10^{-4} \text{ m}^{-1}$ .

Starting from depths of 2000-2500 m the deviation of measured hydrostatic pressure from calculated value corresponds to quadratic law, i.e. the non-linear law.

Formula (17) represents the sum of initial two expansion terms in series of more general formula,  $k \ll 1$ :

$$P = P_0 \exp(kH), \quad \rho = \rho_0 \exp(kH) \quad (18)$$

Derived average value of the constant « $k$ » corresponds to the value of diagnosing measure calculated according to the proposed algorithm.

The diagram below (figure 2) is drawn on the basis of studied rheological parameters of fluid in the well.

Based on these theoretical and experimental studies we may derive the following **conclusions**:

- it has been established that the particles of solid bodies left in well in a suspended condition are distributed unevenly along the borehole depth. Concentration of these particles increases with depth;
- hydrostatic pressure values measured in wells under the drilling are almost coincide for depths down to 900-1000 m with those calculated according to formula  $P = \rho_0 g H$ , where  $\rho_0$  is density of drilling mud at well output;

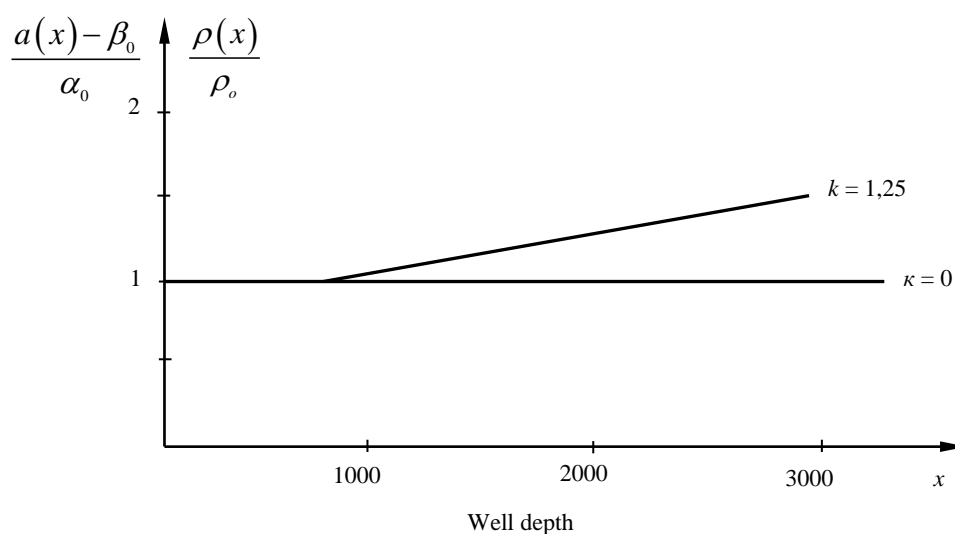

Figure 2 – Relative density of oil variation versus well depth

- starting from 900 – 1000 m depths and below the measured hydrostatic pressure values deviate from calculated values. Hydrostatic pressure measured in three wells under the drilling process displayed that deviation of measured hydrostatic pressure value from calculated value down to 2000-2500m takes place according to linear law;

– particles of solid bodies left in well in a suspended condition are in the gravity field of Earth and therefore they are the subject of Boltzmann distribution along the depth of borehole;

– applying Landau-Lipschitz model of acoustic waves propagation in homogeneous fluid the mathematical model of acoustic waves propagation in inhomogeneous fluid has been developed for oil wells where rheological parameters of fluid vary with depth.

**С. Р. Расулов<sup>1</sup>, Г. Т. Гасанов<sup>1</sup>, А. Н. Зейналов<sup>2</sup>**

<sup>1</sup>Әзірбайжан мемлекеттік мұнай және өнеркәсіп университеті, Баку, Әзірбайжан;

<sup>2</sup>«Мұнай, газ және химияның геотехнологиялық мәселелері» ҒЗИ, Баку, Әзірбайжан

### МҰНАЙ ҰНҒЫМАСЫНДАҒЫ РЕОЛОГИЯЛЫҚ МЕНШІКТЕРДІҢ АКУСТИКАЛЫҚ ДИАГНОСТИКАСЫ

**Аннотация.** Мақалада ұңғыма түбіндегі құм тығындыларының аймағын тазартуға арналған импульсті толқын әрекеті басқа әсер ету әдістерімен салыстырғанда тиімдірек және экологиялық таза екендігі көрсетілген. Қолданылатын акустикалық толқындық әсердің тиімділігі негізгі физикалық процестерді ескере

отырып, математикалық үлгіні дұрыс таңдауға байланысты болады. Ұңғыма түбіндегі құм тығындыларының аймағын акустикалық әсермен жоюдың математикалық моделін құрастыру кезінде ұңғыманың тереңдігімен байланысты мұнайдың реологиялық параметрлерінің өзгеруін ескеру қажет. Физикалық тұрғыдан алғанда, бұл біртектес емес ортадағы акустикалық толқындардың таралуын зерттеу керек екенін білдіреді. Ұңғымадағы мұнайдың реологиялық параметрлері тереңдікке байланысты өзгереді. Айта кетейік, бұл мәселе мұндай тұжырымда шешілмеген.

Ұңғымада суспензияда қалған қатты заттар Жердің тартылыс өрісінде болатындығы анықталды, сондықтан олар ұңғыманың тереңдігі бойынша Больцманға таралуы керек. Қарастырылған жағдайда Эйнштейн ұсынған модель екі фазалы жүйелердің тұтқырлығын анықтауға арналған. Майдың көлемді тұтқырлығы қатты денелерде болған кезде өзгереді.

Мұнайдың реологиялық параметрлері өзгерісінің ұңғыманың тереңдігіне тәуелділігі Ландам - Лифшиц ұсынған теңдеу үшін кері есепті шешуге математикалық түрде азаяды. Кері мәселе жоғарыда келтірілген теңдеудің шешімінен құндықтың екі учаскесінде уақытында акустикалық толқынның алдын-ала өзгеруі туралы белгілі ақпараттармен керекті шаманы анықтау болып табылады.

Ландау-Лифшиц моделін біртекті сұйықтықта акустикалық толқындардың таралуында қолдана отырып, мұнай ұңғымаларында гетерогенді сұйықтықта акустикалық толқындардың таралуының математикалық моделі жасалды, мұнда сұйықтықтың реологиялық параметрлері ұңғыманың тереңдігінің өзгеруімен өзгеруі керек.

Терең манометрлермен бұрғыланған ұңғымалардағы гидростатикалық қысымды өлшеу гидростатикалық қысымның есептелген мәнінен 2000-2500 м тереңдікке ауытқуы сызықтық заңға сәйкес жүретінін, содан кейін сызықтық емес заң пайда болатындығын көрсетті.

Ұңғымадағы сұйықтықтың реологиялық параметрлерін диагностикалау зерттеулерінің негізінде мұнайдың салыстырмалы тығыздығы өзгерісінің ұңғыманың тереңдігіне графикалық тәуелділігі құрылды.

**Түйін сөздер:** акустикалық диагностика, реология, мұнай, ұңғыма, құм ашасы, акустикалық толқындар, математикалық модель.

**С. Р. Расулов<sup>1</sup>, Г. Т. Гасанов<sup>1</sup>, А. Н. Зейналов<sup>2</sup>**

<sup>1</sup>Азербайджанский государственный университет нефти и промышленности, Баку, Азербайджан;

<sup>2</sup>НИИ «Геотехнологические проблемы нефти, газа и химия», Баку, Азербайджан

## **АКУСТИЧЕСКОЕ ДИАГНОСТИРОВАНИЕ РЕОЛОГИЧЕСКИХ СВОЙСТВ НЕФТИ В СКВАЖИНЕ**

**Аннотация.** В статье показано, что импульсное волновое действие для очистки призабойной зоны от песчаной пробки является более эффективным и экологически целесообразным по сравнению с другими методами воздействия. Эффективность применяемого акустического волнового воздействия существенно зависит от правильного выбора математической модели с учетом основных физических процессов. При составлении математической модели ликвидации песчаной пробки в призабойной зоне акустическим воздействием необходимо учесть изменение реологических параметров нефти, связанных с глубиной скважины. Физически это означает, что необходимо исследовать распространение акустических волн в неоднородной среде, так как реологические параметры нефти в скважине изменяется с изменением глубины. Отметим, что этот вопрос в такой постановке не решён.

Определено, что частицы твердых тел, оставшихся в скважине во взвешенном состоянии, находятся в поле тяготения Земли и поэтому по глубине скважины они подчиняются распределению Больцмана. В рассматриваемом случае использовалась модель, предложенная Эйнштейном для определения вязкости двухфазных систем. Объемная вязкость нефти изменяется при наличии в ней частицы твердых тел.

Зависимость изменения реологических параметров нефти от глубины скважины математически сводится к решению обратной задачи для уравнения, предложенного Ландау-Лифшицам. Обратная задача заключается в определении искомой величины из решения вышеуказанного уравнения при известных информациях об изменении фронта акустической волны во времени на двух сечениях скважины.

Применяя модель Ландау-Лифшиц о распространении акустических волн в однородной жидкости, разработана математическая модель распространения акустических волн в неоднородной жидкости в условиях нефтяных скважин, где реологические параметры жидкости подлежат изменению при изменении глубины скважины.

Измерения гидростатического давления в трех бурящихся скважинах глубинными манометрами показали, что отклонение измеренного значения гидростатического давления от вычисленного до глубины 2000-2500 м происходит по линейному закону, после чего имеет место нелинейным закон.

На основании проведенных исследований диагностирования реологических параметров жидкости в скважине построена графическая зависимость изменения относительной плотности нефти от глубины скважины.

**Ключевые слова:** акустическое диагностирование, реология, нефть, скважина, песчаная пробка, акустические волны, математическая модель.

#### Information about authors:

Rasulov Sakit Rauf, doctor of technical sciences, professor, head of the department, Azerbaijan State Oil and Industry University, Baku, Azerbaijan Republic; rasulovsakit@gmail.com; <https://orcid.org/0000-0002-1548-3143>

Hasanov Ghafar Teymur, doctor of physical and mathematical sciences, professor, Azerbaijan State Oil and Industry University, Baku, Azerbaijan Republic; gasanov\_1940@mail.ru; <https://orcid.org/0000-0002-3132-5524>

Zeynalov Anar Naib, candidate of technical sciences, SRI “Geotechnical problems of oil, gas and chemistry”, Baku, Azerbaijan Republic; anar.zeynalov13@hotmail.com; <https://orcid.org/0000-0002-4872-7255>

#### REFERENCES

[1] Iskenderov D.A., Mamed-zadeh A.M., Yarmamedov S.Kh., Mamedzadeh M.A. Oil-field experience for enhanced efficiency of sand plug cleaning in oil well // Azerbaijan Oil Industry. 2018. N 10. P. 27-32.

[2] Kelbaliyev G.I., Tagiyev D.B., Rasulov S.R. Transport Phenomena in Dispersed Media. Taylor & Francis Group. Boca Raton-London-New York, 2019. 434 p.

[3] Kelbaliyev G.I., Rasulov S.R., Tagiyev D.B., Mustafayeva G.R. Mechanics and Rheology of oil Disperse Systems. Moscow, Russia: Maska, 2017. 478 p.

[4] Matveenko V.I. and Kirsanov S.V. The Viscosity and Structure of Dispersed Systems // Moscow Univ. Chem. Bull., 2011. Vol. 66, N 4. P. 199-228.

[5] Kelbaliyev G.I., Rasulov S.R., Rzaev A.G., Mustafayeva G.R. Rheology of structured oils // Journal of Engineering Physics and Thermophysics, 2017. Vol. 90, N 4. P. 996-1002.

[6] Shenoy A. Heat Transfer to Non-Newtonian Fluids: Fundamentals and Analytical Expressions, New Jersey: Wiley – VCH, 2018, 388 p.

[7] Kelbaliyev G.I., Rasulov S.R., Mustafayeva G.R. Viscosity of structured disperse systems // Theoretical Foundations of Chemical Engineering, 2018. N 3. P. 404-411.

[8] Pirvalova V.V., Prosviryakov E.Yu. Couette-Hiemenz exact solutions for the steady creeping convective flow of a viscous incompressible fluid, with allowance made for heat recovery // Vestn. Sam. State tech. university. Ser. Phys.-mat. Science. 22: 3, 2018. P. 532-548.

[9] De Souza M.P. Modeling the Thixotropic behavior of Structured Fluids // J. Non-Newtonian Fluid Mech., 2009. Vol. 164, N 1. P. 66-75.

[10] Kuznetsov O.L., Yefimova S.A. Application of ultrasound in petroleum industry. M.: Nedra. 1983. 192 p.

[11] Biletsky M., Nifontov I., Ratov B., Deliskesheva D. The problem of drilling mud parameters continuous monitoring and its solution at the example of automatic measurement of its density // News of the National Academy of Sciences of the Republic of Kazakhstan. Series of geology and technical sciences. 2019. Vol. 6 (438). P. 46-53. ISSN 2224-5278. <http://www.geolog-technical.kz/images/pdf/g20196/46-53.pdf>

[12] Masanov Z., Kozhabekov Zh., Tugelbayeva G. and st. Wave spreading in resilient viscous-plastic layer with cavity on rigid base // News of the National Academy of Sciences of the Republic of Kazakhstan. Series of geology and technical sciences. 2019. Vol. 4 (436). P. 62-69. ISSN 2224-5278. <http://www.geolog-technical.kz/images/pdf/g20194/62-69.pdf>

[13] Ganiyev R.F., Ukrainskiy L.E. Non-linear wave mechanics and technologies. Wave and oscillating phenomena in the basis of high technologies. M.: Scientific-Publishing Center “Regular and Chaotic Dynamics”. 2011. 780 p.

[14] Abramov V.O., Mullakayev M.S., et al. The experience of ultrasound effect for restoration of productivity of oil wells. “Neftepromislovoye delo”. 2013. N 6. P. 26-32.

[15] Khojibergenov D., Yanyushkin A., Ibragimova Z.A. and st. Drilling tool with negative drilling force value // News of the National Academy of Sciences of the Republic of Kazakhstan. Series of geology and technical sciences. 2019. Vol. 1 (433). P. 169-175. ISSN 2224-5278. <http://www.geolog-technical.kz/images/pdf/g20191/169-175.pdf>

[16] Hasanov Kh.G. Hydrodynamic researches of interrelation of acoustic and laser radiation with fluid. Baku, publishing house «Stake», 2002. 384 p.

[17] Landau L.D., Lipschitz E.M. Static physics. M.: Nauka, 1990. 568 p.

[18] Volarovich M.P., Tolstoy D.M. Magnetic field effect on fluid viscosity // Physical chemistry journal, 2011. Vol. VIII, issue 4. P. 374-403.

[19] Loskutova Y.V., Prozorova I.V., Yudina N.V., Rikkanen S.V. Change in the Properties of oil Disperse Systems Upon a Vibrational Treatment // Colloid Journal, 2005. Vol. 67, N 5. P. 602-611.

[20] Kelbaliyev G.I., Rasulov S.R. Hydrodynamics and Mass Transfer in Disperse Medium. Sankt-Petersburg, Russia: Chemizdat, 2014, 568 p.

NEWS

OF THE NATIONAL ACADEMY OF SCIENCES OF THE REPUBLIC OF KAZAKHSTAN

SERIES OF GEOLOGY AND TECHNICAL SCIENCES

ISSN 2224-5278

Volume 2, Number 440 (2020), 148 – 155

<https://doi.org/10.32014/2020.2518-170X.42>

UDC 624.21:620.178

V. G. Solonenko<sup>1</sup>, N. M. Makhmetova<sup>1</sup>, V. A. Nikolaev<sup>2</sup>,  
M. Ya. Kvashnin<sup>1</sup>, I. A. Bazanova<sup>1</sup>, K. K. Joldassova<sup>1</sup>

<sup>1</sup>Kazakh Academy of Transport and Communications named by M. Tynyshpaev, Almaty, Kazakhstan;

<sup>2</sup>Omsk State Transport University, Omsk, Russia.

E-mail: v.solonenko@mail.ru, makhmetova\_n1958@mail.ru, NikolaevVA@omgups.ru,  
kvashnin\_mj55@mail.ru, inna\_bazanova@mail.ru, bekkur73@mail.ru

## INFLUENCE OF APPENDIX POINT LOAD TRAINING ON MAGNITUDE OF SIDE POWER

**Abstract.** An alternative method of restoring the force factors acting on the rail during operation is proposed. The method is based on the use of influence matrices that bind the forces acting on the rail with stresses in the places where the strain gauges stick. As elements of the basic set of power factors restored by the proposed method, the vertical force (FZ), lateral force (FY) and moment (M) from the displacement of the vertical force away from the center of the rail head are selected.

**Key words:** rail, stress, strain, vertical and lateral forces, stress-strain state, influence matrix.

In the general case, the resultant force acts on the rail head on the wheel side at the point of contact, which is usually laid out on the vertical, lateral and longitudinal components. The method of measuring (restoring) lateral forces acting from a wheel on a rail, stated in [1], does not specifically describe the positions of the contact point on the surface of the head, i.e. points of application of vertical force relative to the center of the rail head, thereby implying the independence of the values of lateral forces on the rail obtained by the Schlumpf method from the position of the conditional center of the contact patch on the rail head.

This paper outlines the method for determining the force factors (including lateral forces) acting on the rail during operation, allowing you to perform the appropriate field tests at any position of the contact point in a pair of "wheel-rail". In the course of the work, mathematical models of a fragment of a rail-sleeper grid on sleepers with elastic intermediate rail fastenings in a ballast layer, models for carrying out virtual gauge (calibration) rail loads were built. The constructed computational models allow, by computation, to obtain mathematical matrices (influence matrices) necessary to restore vertical and lateral loads from the wheel to the track, as well as to obtain the value of the displacement of the contact point in a pair of "wheel-rail".

Calibration tests were carried out by stepwise loading of the rail section of the track with vertical and horizontal jacks (rods). During the tests, the readings of strain gauges (figure 1), mounted directly on the rods of the loading jacks, and the readings of the strain gauge circuit on the rail neck (figure 2), collected by the Schlumpf method, were recorded. The rail was loaded with a vertical force  $F_Z$  in the middle of the head and when the point of application of force was displaced from the center of the head inward (force  $F_B$ ) and out (force  $F_Z$ ) by 25 mm in the path curve. A comparison of the experimental values of the lateral forces  $F_Y$  in the rods with the restored values of the lateral forces according to the Schlumpf method is presented in figure 3.

As a result of the experiments, graphs of the lateral force on the rail head were obtained obtained by the Schlumpf method and directly from the loading jacks (figure 1-3), with a different position of the point of application of vertical force on the rail head.

From the results obtained in the experiment:

- when a vertical force is applied in the middle of the rail head a relatively acceptable degree of deflection of the restored lateral force is observed according to Schlumpf's indications;
- when a vertical force is applied with a deviation from the center of the rail head and in the absence of lateral force, a non-zero lateral force is restored according to the indications of Schlumpf's scheme;
- when a vertical force is applied with a deviation from the center of the rail head by 25 mm in/out of the curve, there is a substantial discrepancy between the lateral force restored by the Schlumpf method and the lateral force applied.

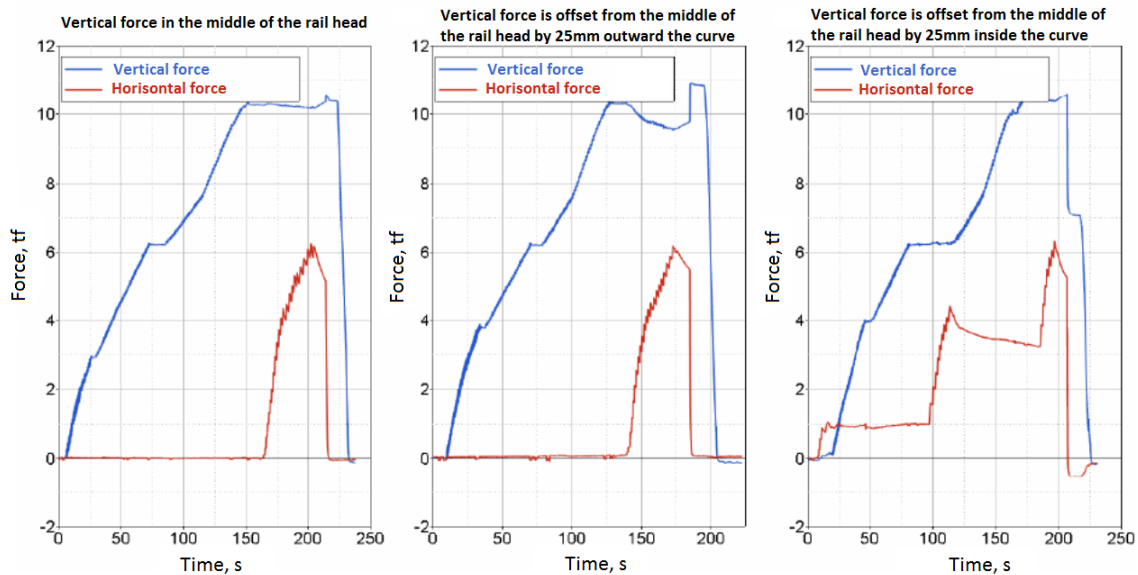

Figure 1 – Change of forces in loading rams jacks at different positions of the point of application of vertical force, tf

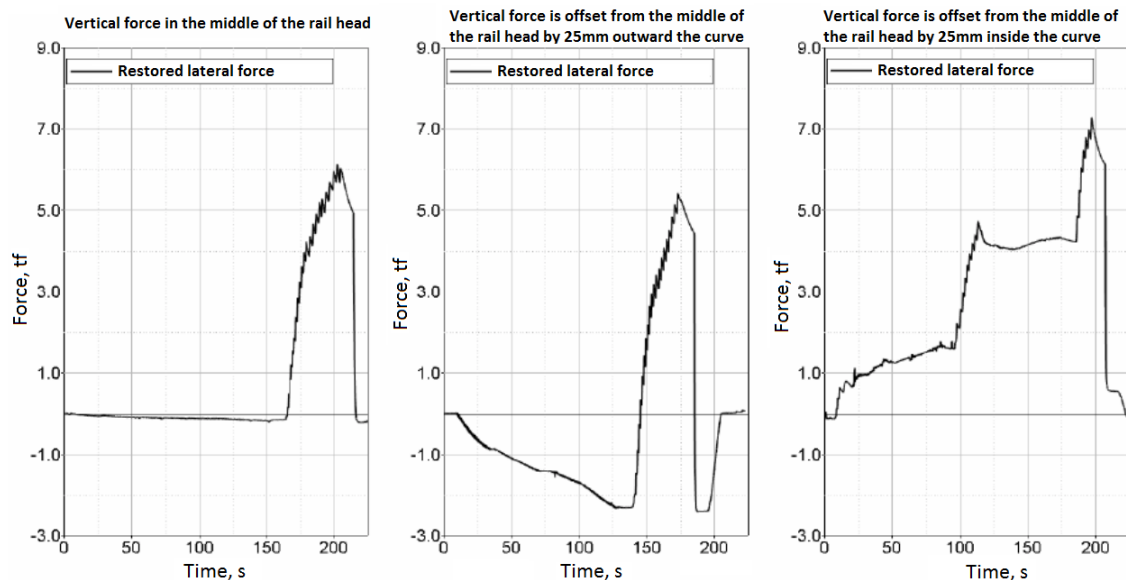

Figure 2 – Change of lateral forces restored by the Schlumpf method at various positions of the point of application of vertical force, tf

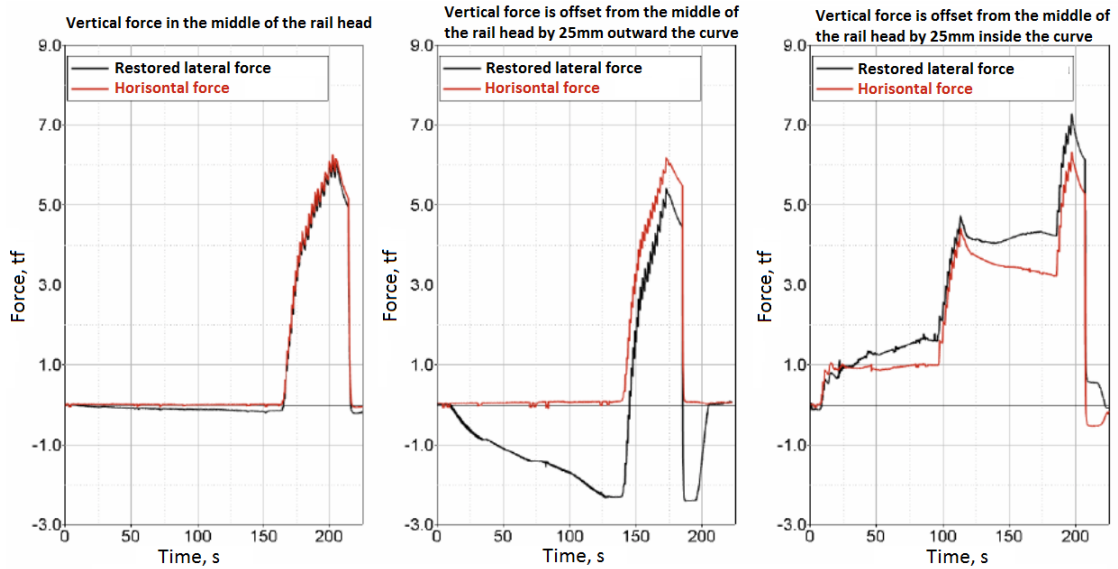

Figure 3 – Change of forces in the jack, creating lateral loading of the rail, and lateral forces reconstructed by the Schlumpf method at different positions of the vertical force application point

The findings of the results of experimental studies require the establishment of the limits of applicability of the Schlumpf method as a means for restoring forces from the wheel to the rail. For this purpose, calculated finite element models of a rail loaded with vertical ( $F_Y = 120 \text{ kN}$ ) and lateral ( $F_Y = 45 \text{ kN}$ ) concentrated forces in various combinations in sections above the support and between the supports were developed.

The stress-strain states of the rail were studied at different positions of the point of application of vertical force to its head: along the axis of the rail and displaced from the axis by  $d=24.5 \text{ mm}$ . The values of stresses in the control points on the rail neck, corresponding to the installation sites of strain gauges for determining lateral forces from the wheel to the rail in accordance with GOST 55050-2012, were recorded. A diagram of the rail section with the location of the points of application of concentrated forces and control points is shown in figure 4.

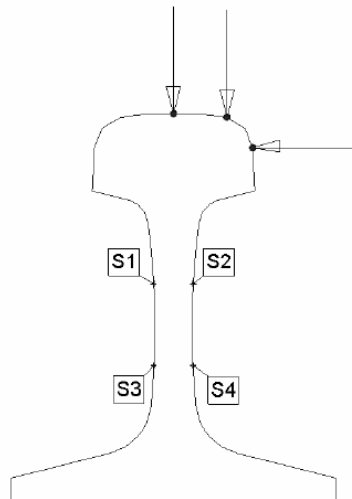

Figure 4 – Scheme of the rail section with the location of points of concentrated application forces and control points

The data obtained show a clear dependence of the distribution of the bending moment along the height of the neck both on the position of the point of application of the vertical force and on the factor of the presence of a support under the loaded rail section.

The stress values at the control points for loading the rail between the supports at the same time with vertical force without displacement and lateral force made the difference  $(S1-S2) - (S3-S4) = \underline{48.6MPa}$ . Considering the value of  $\underline{51.3MPa}$ , it can be concluded that relatively close values of bending moments in the control sections of the neck, i.e. close values of lateral force. In this case, the lateral force was absent in the loading scheme.

Table 1 shows the stress values at the test points on the rail neck in accordance with GOST 55050-2012. Changes of the bending moment along the rail neck height, in general, can be associated with the application of a lateral force to the rail head or with a displacement of the vertical force on the rail head away from the rail axis. Therefore, the method of restoring lateral forces from the wheel to the rail by the Schlumpf method can be used only in cases of absence relative to a significant displacement of the center of the contact patch from the rail section axis.

Table 1 – Values of normal vertical stresses (MPa) at the control points on the rail neck for various design schemes

Design parameters	Control points				S1-S2	S3-S4	S1-S2-S3+S4
	S1	S2	S3	S4			
$\left. \begin{matrix} F_z \neq 0 \\ F_y = 0 \end{matrix} \right\}$ between supports $d = 0$	-35.1	-35.2	-17.7	-17.7	-0.003	0.002	-0.01
$\left. \begin{matrix} F_z \neq 0 \\ F_y = 0 \end{matrix} \right\}$ above the support $d \neq 0$	7.1	-115.2	1.2	-101.8	122.4	102.9	19.2
$\left. \begin{matrix} F_z \neq 0 \\ F_y = 0 \end{matrix} \right\}$ between supports $d \neq 0$	24.9	-95.7	16.8	-52.5	120.6	69.3	51.3
between supports $d \neq 0$	-54.1	-15.7	-61.1	26.1	-38.4	-87.1	48.6

In this case, it is necessary to choose the cross section of the rail above the sleeper as the measuring one. The data and conclusions obtained as a result of computational and experimental studies are in complete agreement [2-9]. The identified limitations of the Schlumpf method for restoring lateral forces from a wheel to a rail require the development of a more universal method that takes into account possible deviations of the center of the contact patch from the axis of the rail section.

The need to introduce an additional factor that takes into account the displacement  $d$  of the point of application of forces from the contact of the wheel with the rail is shown by the experiment described above. It would be logical to associate this factor with the difference in the values of the forces  $F_B$  and  $F_H$  - by the vertical forces when the point of its application moves inwards and outwards of the path curve, respectively. Taking into account the deviations from the center of the rail head  $d$ , we obtain the physical meaning in the form of the momentum  $M = (F_B - F_H) \cdot d$ . The vertical force applied at any point of the rail head over the cross section with load cells can be replaced by a force  $F_Z$  in the middle of the rail head and a moment  $M$ .

To obtain a connection between the readings of the load cells and the loads, calibration experiments are carried out. From a technical point of view, four loading options would be appropriate: 1) A vertical force in the middle of the rail head; 2) Simultaneously with the vertical force in the middle of the rail head  $F_Z^{T2}$  and the lateral force  $F_Y^{T2}$ ; 3) A vertical force shifted  $d$  outwards from the center of the rail head  $F_Z^{T3}$ ; 4) Vertical force, shifted by  $d$  inward from the middle of the rail head  $F_Z^{T4}$  the results of the load cells are recorded in table 2. Using linear superposition, we obtain the matrix  $[G]$  for the desired strength factors (table 3).

Table 2 – Indications of strain gauges

Number of the strain gauge	$\overline{F_Z^{T1} = \dots tf}$	$\overline{\frac{F_Z^{T2} = \dots tf}{F_Y^{T2} = \dots tf}}$	$\overline{F_{Z_H}^{T3} = \dots tf}$	$\overline{F_{Z_B}^{T4} = \dots tf}$
1	$S_1^{T1}$	$S_1^{T2}$	$S_1^{T3}$	$S_1^{T4}$
2	$S_2^{T1}$	$S_2^{T2}$	$S_2^{T3}$	$S_2^{T4}$
3	$S_3^{T1}$	$S_3^{T2}$	$S_3^{T3}$	$S_3^{T4}$
4	$S_4^{T1}$	$S_4^{T2}$	$S_4^{T3}$	$S_4^{T4}$

Table 3 – Matrix coefficients [G] with 4 calibration experiments

Number of the strain gauge	$\overline{F_Z = 1 tf}$	$\overline{F_Y = 1 tf}$	$\overline{M = 1 tf \cdot mm}$
1	$g_{11} = s_1^{T1}/F_Z^{T1}$	$g_{21} = (s_1^{T2} - g_{11} \cdot F_Z^{T2})/F_Y^{T2}$	$g_{31} = (s_1^{T3}/F_{Z_H}^{T3} - s_1^{T4}/F_{Z_B}^{T4})/d/2$
2	$g_{12} = s_2^{T1}/F_Z^{T1}$	$g_{22} = (s_2^{T2} - g_{12} \cdot F_Z^{T2})/F_Y^{T2}$	$g_{32} = (s_2^{T3}/F_{Z_H}^{T3} - s_2^{T4}/F_{Z_B}^{T4})/d/2$
3	$g_{13} = s_3^{T1}/F_Z^{T1}$	$g_{23} = (s_3^{T2} - g_{13} \cdot F_Z^{T2})/F_Y^{T2}$	$g_{33} = (s_3^{T3}/F_{Z_H}^{T3} - s_3^{T4}/F_{Z_B}^{T4})/d/2$
4	$g_{14} = s_4^{T1}/F_Z^{T1}$	$g_{24} = (s_4^{T2} - g_{14} \cdot F_Z^{T2})/F_Y^{T2}$	$g_{34} = (s_4^{T3}/F_{Z_H}^{T3} - s_4^{T4}/F_{Z_B}^{T4})/d/2$

In matrix form, we can write:

$$\begin{Bmatrix} S_1(t) \\ S_2(t) \\ S_3(t) \\ S_4(t) \end{Bmatrix} = \begin{bmatrix} g_{11} & g_{21} & g_{31} \\ g_{12} & g_{22} & g_{32} \\ g_{13} & g_{23} & g_{33} \\ g_{14} & g_{24} & g_{34} \end{bmatrix} \cdot \begin{Bmatrix} F_Z(t) \\ F_Y(t) \\ M(t) \end{Bmatrix} = [G] \cdot \{F(t)\}$$

By calculating the pseudo inverse to [G] matrix  $[G]^+ = ([G]^T \times [G])^{-1} \times [G]^T$  obtain the possibility of determining (restoring) force factors according to the indications of strain gauges:

$$\begin{Bmatrix} F_Z(t) \\ F_Y(t) \\ M(t) \end{Bmatrix} = [G]^+ \cdot \{S(t)\}.$$

In case of technical difficulties in loading the rail with a vertical force on the inside of the head, the first three calibration tests are sufficient. Then the coefficients of the matrix [G] will be made of table 4.

According to the results of the performed computational studies, a technique is proposed for the experimental determination (restoration) of the force factors acting on the rail during operation.

Table 4 – Matrix coefficients [G] with 3 calibration experiments

Number of the strain gauge	$\overline{F_Z = 1 tf}$	$\overline{F_Y = 1 tf}$	$\overline{M = 1 tf \cdot mm}$
1	$g_{11} = s_1^{T1}/F_Z^{T1}$	$g_{21} = (s_1^{T2} - g_{11} \cdot F_Z^{T2})/F_Y^{T2}$	$g_{31} = (s_1^{T3}/F_{Z_H}^{T3} - g_{11})/d$
2	$g_{12} = s_2^{T1}/F_Z^{T1}$	$g_{22} = (s_2^{T2} - g_{12} \cdot F_Z^{T2})/F_Y^{T2}$	$g_{32} = (s_2^{T3}/F_{Z_H}^{T3} - g_{12})/d$
3	$g_{13} = s_3^{T1}/F_Z^{T1}$	$g_{23} = (s_3^{T2} - g_{13} \cdot F_Z^{T2})/F_Y^{T2}$	$g_{33} = (s_3^{T3}/F_{Z_H}^{T3} - g_{13})/d$
4	$g_{14} = s_4^{T1}/F_Z^{T1}$	$g_{24} = (s_4^{T2} - g_{14} \cdot F_Z^{T2})/F_Y^{T2}$	$g_{34} = (s_4^{T3}/F_{Z_H}^{T3} - g_{14})/d$

At each instant of time t, the power factors to be restored are determined by the formulas:

$$F_Z(t) = 0.009582 \cdot s_1(t) + 0.007845 \cdot s_2(t) + 0.009878 \cdot s_3(t) + 0.00804 \cdot s_4(t),$$

$$F_Y(t) = 0.00123 \cdot s_1(t) + 0.002916 \cdot s_2(t) + 0.001529 \cdot s_3(t) - 0.00275 \cdot s_4(t),$$

$$M(t) = 0.182746 \cdot s_1(t) + 0.038209 \cdot s_2(t) - 0.18386 \cdot s_3(t) - 0.04411 \cdot s_4(t).$$

wheres<sub>1</sub>, s<sub>2</sub>, s<sub>3</sub>, s<sub>4</sub>, are the readings of the strain gauges.

Figure 5-6 show the recovered proposed method of implementing the vertical and lateral forces superimposed on the recording of the load cells on the loading jacks (rods). It can be seen that the method gives errors in determining the lateral force (at the time of reaching the maximum values of the experiment) with the application of vertical force:

- In the middle of the rail head 0.28%;
- With a deviation from the middle of the rail head by 25 mm outwardly, the curve path is 4.22%;
- With a deviation from the middle of the rail head by 25 mm inside the curve path 2.58%.

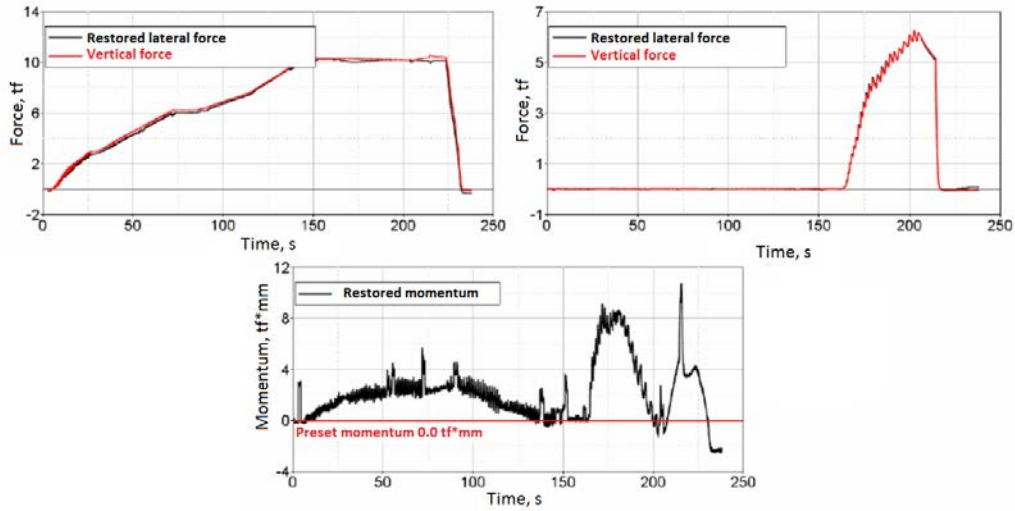

Figure 5 – Calibration loading T1. Power factors and reconstructed using the influence matrix

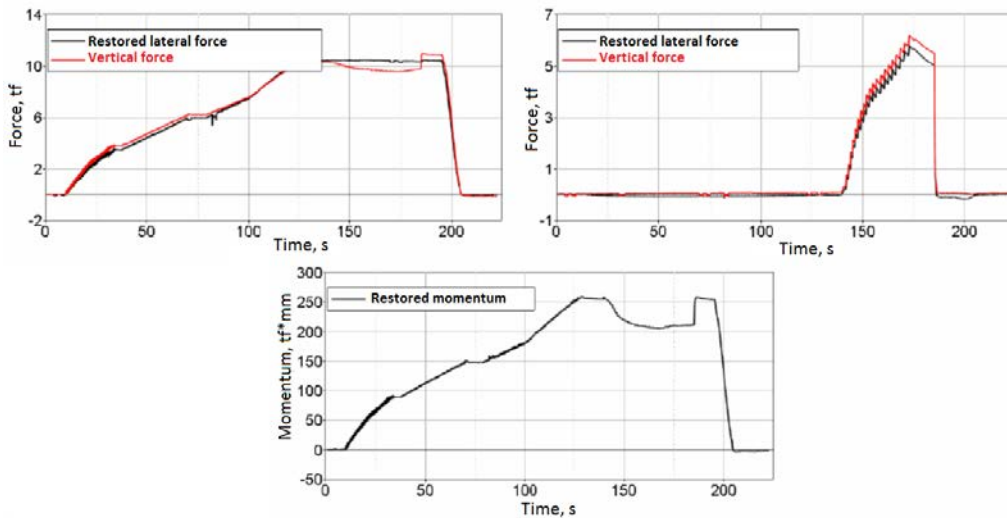

Figure 6 – Calibration loading T2. Power factors and reconstructed using the influence matrix

**Conclusions** can be drawn from the results of the above studies:

- When a vertical force is applied in the middle of the rail head, the applied lateral force is restored according to the indications of the Schlumpf scheme;
- When a vertical force is applied with a deviation from the center of the rail head and in the absence of lateral force, a nonzero lateral force is restored according to the indications of the Schlumpf scheme;
- When a vertical force is applied with a deviation from the center of the rail head by 25 mm inside / outside of the curve, the lateral force is not restored according to the Schlumpf scheme indications.

В. Г. Солоненко<sup>1</sup>, Н. М. Махметова<sup>1</sup>, В. А. Николаев<sup>2</sup>,  
М. Я. Квашнин<sup>1</sup>, И. А. Базанова<sup>1</sup>, К. К. Джолдасова<sup>1</sup>

<sup>1</sup>М. Тынышбаев атындағы Қазақ көлік және коммуникациялар академиясы, Алматы, Қазақстан;

<sup>2</sup>Омбы мемлекеттік жол қатынасы университеті, Омбы, Ресей

### ПОЕЗД САЛМАҚ КҮШІНІҢ ТҮСУ НҮКТЕСІНІҢ БҮЙІР КҮШТІҢ ШАМАСЫНА ӘСЕРІ

**Аннотация.** Пайдалану кезінде рельске түсетін күш факторларын қалпына келтірудің балама әдісі ұсынылған. Әдіс тензорезистор желімделген орындардағы рельске түсетін кернеу мен күшті байланыстыратын әсер ету матрицасына негізделген. Ұсынылған әдіс бойынша қалпына келтіруде, күш факторларының базистік жиынтығының элементі ретінде таңдалды: көлденең күш (FZ), бүйірлік күш (FY) және рельс басынан көлденең күштің ортадан шетке қарай ауысуынан пайда болатын момент (M).

Бұл жұмыста «доңғалақ-рельс» жұптаса отырып түйісу нүктесінің кез келген жерінде дала сынақтарын өткізуге мүмкіндік беретін және пайдалану кезінде рельске әсер ететін, күш факторларын (соның ішінде бүйірлік күштер) анықтау әдістемесін сипатталады.

Жылжымалы құрам рельстің бойымен қозғалған кезде жүктемелерді алуға (қалпына келтіруге) арналған әмбебап тәсіл әзірленді. Ұсынылған тәсілдегі жүктемелер рельс деформацияларымен анықталады (қалпына келтіріледі). Зерттеу нәтижелерін рельс жолының жүктелуін бағалау және нормативтік-құқықтық базаны жақсарту үшін пайдалануға болады.

Жұмыс барысында балласты қабаттағы серпімді аралық бекітпелері бар шпалдағы рельс-шпал торының фрагменттерінің математикалық үлгілері, рельсті виртуалды калибрлеу (таралау) жүктеуге арналған модельдер жасалды.

Құрылған есептеу модельдері доңғалақтан рельс жолына тік және бүйірлік жүктемелерді қалпына келтіруге, сонымен қатар «доңғалақ-рельс» жұбының түйісу нүктесінің ығысу көлемін алуға қажетті математикалық матрицаларды (әсер ету матрицаларын) алуға мүмкіндік береді.

Зерттеу нәтижелері бойынша қорытынды жасалды: рельс басының ортасында тік күш қолданылған кезде, Шлюмпф диаграммасына сәйкес қолданылатын бүйірлік күш қалпына келтіріледі; рельс басының ортасынан ауытқумен тік күш қолданылғанда және бүйірлік күш болмағанда, Шлюмпф диаграммасына сәйкес нөлдік емес бүйірлік күш қалпына келтіріледі; рельс басының ортасынан ішке/сыртқа 25 мм ауытқумен тік күш қолданылған кезде, бүйірлік күш Шлюмпф диаграммасына сәйкес қалпына келтірілмейді.

**Түйін сөздер:** рельс, кернеу, деформация, көлденең және бүйір күш, кернеулі-деформациялық кезең (КДК), әсер ету матрицасы.

В. Г. Солоненко<sup>1</sup>, Н. М. Махметова<sup>1</sup>, В. А. Николаев<sup>2</sup>,  
М. Я. Квашнин<sup>1</sup>, И. А. Базанова<sup>1</sup>, К. К. Джолдасова<sup>1</sup>

<sup>1</sup>Казахская академия транспорта и коммуникаций им. М. Тынышпаева, Алматы, Казахстан;

<sup>2</sup>Омский государственный университет путей сообщения, Омск, Россия

### ВЛИЯНИЕ ПОЛОЖЕНИЯ ТОЧКИ ПРИЛОЖЕНИЯ ПОЕЗДНОЙ НАГРУЗКИ НА ВЕЛИЧИНУ БОКОВОЙ СИЛЫ

**Аннотация.** Предложен альтернативный способ восстановления силовых факторов, действующих на рельс в ходе эксплуатации. Способ основан на использовании матриц влияния, связывающих действующие на рельс силы с напряжениями в местах наклейки тензорезисторов. В качестве элементов базисного набора силовых факторов, восстанавливаемых предлагаемым способом, выбраны вертикальная сила (FZ), боковая сила (FY) и момент (M) от смещения вертикальной силы в сторону от середины головки рельса.

В настоящей работе излагается методика определения силовых факторов (в том числе боковых сил), действующих на рельс в ходе эксплуатации, позволяющая выполнять соответствующие натурные испытания при любом положении точки контакта в паре «колесо-рельс».

Выработан универсальный подход к получению (восстановлению) нагрузок на рельсовый путь при движении по нему подвижного состава. Нагрузки в предлагаемом подходе определяются (восстанавливаются) по деформациям рельса. Результаты проведенных исследований могут быть использованы для проведения работ по оценке нагруженности рельсового пути и совершенствования нормативной базы.

В ходе работы построены математические модели фрагмента рельсошпальной решетки на шпалах с упругими промежуточными рельсовыми скреплениями в балластном слое, модели для проведения виртуальных калибровочных (тарировочных) нагружений рельса.

Построенные расчетные модели, позволяют расчетным путем получать математические матрицы (матрицы влияния), необходимые для восстановления вертикальных и боковых нагрузок от колеса на рельсовый путь, а так же получать величину смещения контактной точки в паре «колесо-рельс».

Из результатов исследований сделаны выводы: при приложении вертикальной силы в середине головки рельса прикладываемая боковая сила восстанавливается по показаниям схемы Шлюмпфа; при приложении вертикальной силы с отступлением от середины головки рельса и при отсутствии боковой силы по показаниям схемы Шлюмпфа восстанавливается ненулевая боковая сила; при приложении вертикальной силы с отступлением от середины головки рельса на 25 мм внутрь/наружу кривой не восстанавливается боковая сила по показаниям схемы Шлюмпфа.

**Ключевые слова:** рельс, напряжения, деформации, вертикальные и боковые силы, напряженно-деформированное состояние, матрицы влияния.

#### Information about authors:

Solonenko V.G., Professor, Doctor of Technical Sciences, Kazakh Academy of Transport and Communications named by M. Tynyshpaev, Almaty, Kazakhstan; v.solonenko@mail.ru; <https://orcid.org/0000-0001-6503-6598>

Mahmetova N.M., Professor, Doctor of Technical Sciences, Kazakh Academy of Transport and Communications named by M. Tynyshpaev, Almaty, Kazakhstan; makhmetova\_n1958@mail.ru; <https://orcid.org/0000-0001-7324-5832>

Nikolaev V.A., Professor, Doctor of Technical Sciences, Omsk State Transport University, Omsk, Russia; NikolaevVA@omgups.ru; <https://orcid.org/0000-0002-0850-1796>

Kvashnin M.Ya., Professor, Ph.D., Kazakh Academy of Transport and Communications named by M. Tynyshpaev, Almaty, Kazakhstan; kvashnin\_mj55@mail.ru; <https://orcid.org/0000-0002-3969-9299>

Bazanova I.A., Professor, Doctor of Technical Sciences, Kazakh Academy of Transport and Communications named by M. Tynyshpaev, Almaty, Kazakhstan; inna\_bazanova@mail.ru; <https://orcid.org/0000-0003-1899-0092>

Joldassova K.K., senior lecturer, Kazakh Academy of Transport and Communications named by M. Tynyshpaev, Almaty, Kazakhstan; bekkur73@mail.ru; <https://orcid.org/0000-0001-6272-9567>

#### REFERENCES

[1] GOST R 55050-2012 Railway rolling stock. Norms of permissible impact on the path and test methods [Zheleznodorozhnyy podvizhnoy sostav. Normy dopustimogo vozdeystviya na put' i metody ispytaniy] [Tekst] / M.: Standartinform, 2013. 29 p. (in Russ.).

[2] Kvashnin M.Ya., Burombayev S.A., Bondar' I.S., Zhangabylova A.M. The vibrodynamic effects of locomotives with high axial loads on the railway track and beam bridge spans [Vliyaniye vibrodinamicheskogo vozdeystviya lokomotivov s vysokimi osevmi nagruzkami na zh.d. put' i balochnyye zh.b. proletnyye stroyeniya mostov] // Trudy KHII Mezhdunarodnoy nauchno-tekhnicheskoy konferentsii «Sovremennyye problem proyektirovaniya, stroitel'stva i ekspluatatsii zheleznodorozhnogo puti». Chteniya, posvyashchennyye pamyati professora G.M. Shakhunyantsa. M.: MGUPS (MIIT), 2015. P. 163-166 (in Russ.).

[3] Kvashnin M.Ya., Bondar' I.S., Rystygulov P.A., Kystaubayev S.B. Experimental studies of the construction of railway bridges reinforced with composite material [Eksperimental'ny yeissledovaniya konstruktivnykh zheleznodorozhnykh mostov, usilivayemykh kompozitnym materialom] // Trudy Shestnadtsato ynauchno-prakticheskoy konferentsii «Bezopasnost' dvizheniyapoyezdov». M.: MGUPS (MIIT), 2015. P. 43-47 (in Russ.).

[4] Burombayev S.A., Kvashnin M.Ya. Diagnostika i monitoring iskusstvennykh sooruzheniy magistral'nykh liniy AO «NK «K, TZH» // Vestnik KazATK. N 3 (98), 2016. P. 38-57 (in Russ.).

[5] Bondar' I.S. Vliyaniye podvizhnoy nagruzki na deformatsii proletnogo stroyeniya zheleznodorozhnogo mosta // Sbornik trudov s Mezhdunarodnym uchastiyem. Vypusk 7 – «Inzhenernyye sooruzheniya na transporte», M.: MGUPS (MIIT), 2016. P. 64-67.

[6] Makhmetova N.M., Solonenko V.G., Bekzhanova S.E. The calculation of free oscillations of an anisotropic three-dimensional array of underground structures // News of the National Academy of Sciences of the Republic of Kazakhstan / Series of geology and technical sciences. Iss. 2. N 422. 2017. P. 175-184.

[7] Solonenko V.G., Makhmetova N.M., Bekzhanova S.E., Kvashnin M.Ya. Determination of rail voltages after impact of mobile composition // News of the National Academy of Sciences of the Republic of Kazakhstan / Series of geology and technical sciences. Iss. 5. N 425. 2017. P. 262-269.

[8] Solonenko V.G., Makhmetova N.M., Musayev J.S., Bekzhanova S.E., Kvashnin M.Ya. The method of limiting speed when passing turnouts of railway vehicles with bogies of model zk1 // News of the National Academy of Sciences of the Republic of Kazakhstan / Series of geology and technical sciences. Iss. 1. N 433. 2019. P. 151-162 (in Eng.) <http://doi.org/10.32014/2019.2518-170X.19>

[9] Solonenko V.G., Makhmetova N.M., Musayev J.S., Bekzhanova S.E., Kvashnin M.Ya. Stresses in elements of metal railway bridges under the action of the crew // News of the National Academy of Sciences of the Republic of Kazakhstan / Series of geology and technical sciences. Iss.2. N 434. 2019. P. 151-162 (in Eng.). <http://doi.org/10.32014/2019.2518-170X.50>

**NEWS**

OF THE NATIONAL ACADEMY OF SCIENCES OF THE REPUBLIC OF KAZAKHSTAN

**SERIES OF GEOLOGY AND TECHNICAL SCIENCES**

ISSN 2224-5278

Volume 2, Number 440 (2020), 156 – 161

<https://doi.org/10.32014/2020.2518-170X.43>

UDC 343.846

**R. N. Klyuchko<sup>1</sup>, G. S. Dzhumashev<sup>2</sup>**

<sup>1</sup>Head of the Department of criminal law, criminal procedure and criminalistics  
of the Grodno state University named after Ya. Kupala, Republic of Belarus;

<sup>2</sup>Applicant for the Department of criminal law of Ya. Kupala Grodno state University  
(Republic of Belarus), Astana, Kazakhstan.

E-mail: [g\\_djumashev@mail.ru](mailto:g_djumashev@mail.ru)

**PROBATIONAL CONTROL FOR PERSONS SUBJECT  
TO CONDITIONAL-EARLY EXEMPTION**

**Abstract.** Since January 1, 2015, the criminal Executive inspections Of the Committee of the criminal Executive system of the Ministry of internal Affairs of the Republic of Kazakhstan have been transformed into the probation service with the expansion of the function of assistance in obtaining social and legal assistance and the implementation of probation control. In this regard, the issues of formation and development of the Institute of probation in the Republic of Kazakhstan are revealed.

Due to the fact that a significant part of crimes among persons released on parole from places of deprivation of liberty is committed due to social problems, it is necessary to carry out work on their re-socialization for persons subject to release on parole, as established by law in relation to convicts serving a sentence of imprisonment, which remained until one year of their sentence. In addition, it is planned to expand the use of penitentiary control in relation to persons subject to parole.

The article also analyzes the criteria for correcting prisoners convicted from the perspective of factors that affect the degree of reduction of a person's public danger, taking into account the analysis of the practice of conditional release, domestic law, and the opinions of leading lawyers – scientists. Based on the results of this analysis, a scientific and legal description of the term “correction” is proposed, as well as the procedure and conditions for the implementation of probationary control.

The analysis of materials on conditional release from punishment also indicates that by refusing to satisfy petitions and representations, judges basically motivate their decision by a combination of necessary circumstances characterizing the personality of the convicts. In addition, the court is based only on information provided by the administration of institutions on convicts, which, in our opinion, is formal in nature and is not sufficient to resolve the issue of parole. In this regard, it is proposed to provide the conclusion on the correction of the convicted person and the possibility of applying conditional early release to him to the employees exercising probation control in this institution. Then the court, having studied the materials of the probation services and the administration of the institution, will take an appropriate decision.

**Key words:** probationary control, parole, peer control, correction of a convict, social adaptation of a convict, resocialization of a convict, correction of a convict, probation service.

**Introduction.** Correction of convicts is one of the purposes of applying criminal punishment, and the possibility of parole from serving a sentence is the most important incentive for convicts in their positive behavior. At the same time, in order to consolidate the results of the correction, assistance should be provided to persons subject to release from prison. In this direction, a significant role is played by probationary monitoring of the behavior of persons subject to parole.

When conducting probation control in Kazakhstan due to the presence of features on the subject and scope of powers of participants in probation control, there are a number of problems of a theoretical, legal and organizational nature that were not the subject of a special and independent scientific study. Accordingly, consideration of these problems, ways to solve them, as well as the features of probationary

control over the behavior of persons subject to parole, their essence, are among the important tasks whose solution is associated with the need to carry out appropriate theoretical developments.

Recent domestic and foreign research conducted, often devoted to certain aspects of probation in the Republic of Kazakhstan, in particular, with respect to persons sentenced to probation or to sentences not related to deprivation of liberty.

Many scientific papers also consider other problematic probation issues related to the application of forms and methods of its implementation. At the same time, until now, such aspects of probation control as its implementation in relation to persons subject to parole, the essence of the concept of “degree of correction”, have not been fully investigated and developed.

The probationary activity in Kazakhstan is also not uniform, especially when it comes to organization approaches, forms of implementation, and evaluation of the effectiveness of probationary control. There is a need to improve the legal foundations of this area of activity.

The circumstances outlined indicate the need to study a number of theoretical and applied and applied problems of probationary control over the behavior of persons subject to parole.

Thus, the relevance of the topic of this article is determined by the need to study and analyze the legal foundations of probationary control over the behavior of persons subject to parole.

All this predetermined the choice of topic, the nature and direction of our research, in which an attempt was made to set forth our own vision of further law-making activity in the direction under consideration.

In writing this article, extensive analytical material has been used on the regulatory framework for probationary monitoring of the behavior of individuals subject to parole, contained in the writings of modern legal scholars, and analysis of law enforcement practice.

**Methodology.** The theoretical basis of the study was the scientific works of domestic and foreign legal scholars regarding the problematic aspects of parole of convicts and probationary control in relation to these individuals.

The empirical base of the study is the statistical data of the Committee on Legal Statistics and Special Records of the General Prosecutor's Office of the Republic of Kazakhstan, as well as practical materials on the facts of non-fulfillment by persons released on parole of their duties, as well as information on the improper performance of their official duties by law enforcement officials.

During the study, periodical press materials and Internet sources were used, which discussed issues of probation control and parole. The author conducted a legal analysis of the norms of the criminal and penal legislation of the Republic of Kazakhstan, regulating the procedure for conducting probationary monitoring of persons subject to parole, and also studied the law enforcement practice.

When writing this article, extensive analytical material was used on the legal foundations of probationary control over the behavior of parole in Kazakhstan.

**Results.** In order to increase the effectiveness of probation control aimed at correcting the convict and preventing them from committing new criminal offenses, it is necessary to improve certain aspects of the probationary institution:

1. The application of probationary control should be extended to individuals subject to parole;
2. The conclusion on the correction of the convict and the possibility of applying conditional early release in relation to him must be provided by the employees exercising probation control in this institution.

**Discussion.** For the first time the concept of “probation” in Kazakhstani legislation was introduced by the Law of February 15, 2012 “On Amendments and Additions to Some Legislative Acts of the Republic of Kazakhstan on the Issues of Probation Service” [1].

In accordance with this, on the basis of the order of the Prime Minister of the Republic of Kazakhstan dated April 4, 2012 № 65 on measures to implement the above-mentioned Law, a number of regulatory legal acts were prepared and published, including the Decree of the Government of the Republic of Kazakhstan dated October 23, 2014 № 1131 “On approval of the Rules for the provision of social and legal assistance to persons registered with the probation service” [2] and Order of the Minister of Internal Affairs of the Republic of Kazakhstan dated August 15, 2014 № 511 “On approval of the Rules for the organization of activities of the probation service”, designed for direct regulation of probationary activity [3].

An analysis of the content of these documents shows that probation was controlled only by probation, and the legislator regulated only the control and supervisory and punitive functions in the implementation of probation control, including established forms of accounting and reporting, reconciliations and verification of information regarding data on the category of convicts.

Given these circumstances, in the future, with the adoption of the new Criminal Executive Code of the Republic of Kazakhstan in 2014, the powers of the probation services were expanded, as well as the categories of persons with respect to whom probation control is established [4].

According to Art. 3 PEC RK under probation should be understood as a set of measures of a social and legal nature, developed and implemented individually in relation to a person under probationary control, to correct his behavior in order to prevent him from committing new criminal offenses.

It should be noted that from January 1, 2015, the criminal-executive inspections of the Committee on the Criminal Executive System of the Ministry of Internal Affairs of the Republic of Kazakhstan were transformed into a probation service with an expansion of the function to facilitate the receipt of social and legal assistance and probation, and those sentenced to restricted freedom.

One of the important documents aimed at implementing probation control in the Republic of Kazakhstan, where the activities of probation services are specifically indicated, in the form of tools, is an independent Law of the Republic of Kazakhstan "On Probation", adopted on December 30, 2016 [5].

As the authors of the Commentary on the Law of the Republic of Kazakhstan "On Probation" rightly noted, this law is a new direction in the development of the legal system, gives the Kazakhstani probation model a harmonious system and logical connection between the state and the citizen, lays down the basic humanistic ideas of the state [6, p.15].

In accordance with paragraph 2) of Art. 1 of the Law of the Republic of Kazakhstan "On Probation", "the purpose of probation is to help ensure public safety by: correcting the behavior of the suspect, the accused; resocialization of the convict; social adaptation and rehabilitation of a person released from the institution of the penal system."

Currently, there are four types of probation: pre-trial probation; sentencing probation; penitentiary probation; post-prison probation, which allows us to talk about the continuity of the process of re-socialization of people who find themselves in the field of criminal proceedings, which mainly affects the dynamics of the prison population and the rate of relapse, that is, the repetition of crimes by persons who have served their sentences [7, p.326].

Thus, it can be stated that the establishment of a probationary institution has taken place in Kazakhstan and the entire probationary cycle has been finally formed. Voluntary participation in the re-education of convicts has turned into a professional service with all duties and rights.

One of the most important types of probationary control capable of providing the necessary assistance to prisoners sentenced to prison is probation.

According to Article 72 of the Criminal Code of the Republic of Kazakhstan, a person serving a sentence of restraint of liberty or imprisonment, after the actual serving of the time prescribed by law, may be released by the court on parole, if the court finds that he does not need to complete the sentence for his correction. In this case, a person serving a restraint of liberty or imprisonment, after the actual departure of the deadlines stipulated by law, shall be released on parole in the event of full compensation for the damage caused by the crime and the absence of malicious violations of the established procedure for serving the sentence [8].

When applying this norm, it is difficult for the court to determine the fact that the convicted person does not need to fully serve the sentence for his correction.

Legislative regulation in paragraph 10 of Art. 3 PEC RK the degree of correction of the convict as the formation of his law-abiding behavior, a positive attitude to the person, society, work, norms, rules and ethics of behavior in society does not contribute, in our opinion, to eliminate the "formal" approach to its definition.

Among scholars, there are various opinions on the content side of the concept of "correction of convicts". So, from the point of view of BB Cossack correction of convicts is a complex national task, in the solution of which all government bodies and public organizations related to its implementation should take part [9, p.254].

A.I. Zubkov talks about the correction that he sees in the formation of the personality of convicts in accordance with the “positive, socially useful rules and traditions of human society and the promotion of their law-abiding behavior through educational work, socially useful work, general education, training and public influence carried out in conditions created by the established procedure for the execution and serving of punishment (regime)” [10, p.25].

Thus, the above definitions clearly indicate the difficulties in assessing the degree of correction. As rightly notes I.V. Shmarov “correction can be understood not only as a goal, but also as a process, as well as the result of the application of punishment and corrective action on convicts” [11, p.37-38].

In our opinion, the institution of penitentiary probation can play a significant role in solving this problem.

According to Article 12, 16 of the Law of the Republic of Kazakhstan “On Probation”, penal probation is the activity of the administration of the correctional institution within the framework of the requirements of the PEC from the moment the convicted person is sentenced to imprisonment in this institution, and one year before his release from prison, it also works together with the probation officer to prepare convicted to release.

At the same time, the probation service for their re-socialization is not carried out in relation to convicts on parole, as established by law, in respect of convicts serving a sentence of imprisonment who are left for one year before serving their sentence.

The main task in the preparation of convicts serving deprivation of liberty for parole is the creation of a system of interconnected elements aimed at resolving issues of successful social adaptation of a convicted person after release. First of all, it is necessary to assist in the restoration of socially useful ties; organize vocational and labor training of convicts, which will serve for the convict as a real source of income after release, etc.

As practice shows, a significant portion of crimes among persons on parole from places of deprivation of liberty are committed due to social problems. Among persons released on parole and having committed crimes again, 78% are unemployed. So, parole A. and N. needed employment, however, the probation service, where they were registered, was limited only to sending an individual program for the help of a psychologist. As a result, these persons committed repeated crimes (theft, robbery).

Thus, penitentiary probation should also apply to persons subject to parole.

An analysis of the materials on conditional release from punishment also indicates that by refusing to satisfy applications and representations, judges basically motivate their decision by a combination of necessary circumstances characterizing the personality of the convicted.

The grounds for determining “no correction” and subsequent refusal of parole from serving a sentence by the courts indicate unstable behavior, lack of degree of behavior, a small number of rewards, etc. In addition, the court is based only on information provided by the administration of institutions on convicts, which, in our opinion, is formal in nature and is not sufficient to resolve the issue of parole.

In this regard, we consider it necessary to provide a conclusion on the correction of a convicted person and the possibility of applying conditional early release to him to employees exercising probation control in this institution. Then the court, having studied the materials of the probation services and the administration of the institution, will take an appropriate decision.

**Conclusion.** The above results obtained during the study in the scope of this article allow us to conclude that imperfect penitentiary control of persons subject to parole, which in our opinion requires further study and reflection.

Consideration of the legal problems of probationary activity allows us to conclude that the implementation of the state anti-crime policy can be most effective only through coordinated measures aimed at the re-socialization of prisoners and their social adaptation of crime and other offenses.

It seems that the obtained author's results, on the one hand, can expand the boundaries of scientific knowledge in this area, will contribute to further increase the effectiveness of probationary control, and, on the other, serve as a starting point for further study of these problems.

Р. Н. Ключко<sup>1</sup>, Ғ. С. Джумашев<sup>2</sup>

<sup>1</sup>Қылмыстық құқық, қылмыстық іс жүргізу және криминалистика кафедрасының меңгерушісі, Янка Купала атындағы Гродно мемлекеттік университеті, Беларусь Республикасы;  
<sup>2</sup> Талапкер, қылмыстық құқық кафедрасы, Янка Купала атындағы Гродно мемлекеттік университеті (Беларусь Республикасы), Астана, Қазақстан

### ШАРТТЫ-ЕРТЕ СЫНАҚТАН ӨТЕТІН ЖЕКЕ ТҮЛҒАЛАРҒА АРНАЛҒАН ПРОБАЦИЯ БАҚЫЛАУЫ

**Аннотация.** 1 қаңтарынан бастап 2015 жылғы қылмыстық-атқару инспекциясы қылмыстық-атқару жүйесі Комитеті Қазақстан Республикасы ішкі істер Министрлігінің қайта құрылды пробация қызметіне кеңейтуге жәрдемдесу жөніндегі функциялар алу әлеуметтік-құқықтық көмек көрсетуді жүзеге асырумен, пробациялық бақылау. Осыған байланысты ашылады қалыптасу және даму мәселелері институтының пробация Қазақстан. Сонымен қатар, ашылады қылмыстық-құқықтық табиғаты пробационного бақылау және ұсынылған өз көзқарасын институтының пенитенциарлық пробация мәні өзінен өзі қажетті көмек көрсету бас бостандығынан айыруға сотталған.

Осыған байланысты, қылмыстардың айтарлықтай бөлігі адамдар арасында шартты түрде мерзімінен бұрын босатылған, бас бостандығынан айыру орындарынан жасалатын әлеуметтік проблемаларды қажет жататын адамдарға қатысты мерзімінен бұрын шартты түрде босатылуға бойынша жұмыс жүргізу, оларды қайта әлеуметтендіру де қатысты сотталған, жазасын өтеп бас бостандығынан айыру түрінде тағайындалған жазалау мерзімін өтегенге дейін қалған бір жыл. Одан әрі жетілдіру мақсатында пробациялық бақылау көзделеді қолдану аясын кеңейту, пенитенциарлық бақылау жататын адамдарға қатысты шартты-мерзімінен бұрын босатуға.

Мақалада сондай-ақ, талдау өлшемдерін сотталғандарды түзеу тұрғысынан факторлар әсер етеді төмендеу дәрежесі қоғамдық қауіп тұлға, талдауды ескере отырып, құқық қолдану іс-тәжірибесін шартты түрде мерзімінен бұрын босату, отандық заңнаманың пікірлерін жетекші заңгер – ғалымдар. Аталған талдау нәтижелері бойынша ұсынылған ғылыми-құқықтық сипаттамасы термин "түзету", сондай-ақ тәртібі мен шарттарын пробациялық бақылауды жүзеге асыру.

Жүргізілген талдау туралы материалдарды шартты түрде мерзімінен бұрын жазадан босату, сондай-ақ дәлелдейді отқазывая өтінішхаттарды қанағаттандырудан мен ұсынымдардың, судьялар негізінен ынталандырады өз шешімін жиынтығымен қажетті мән-жайлар жеке басын сипаттайтын сотталған. Үшін негіз ретінде анықтау емес "түзету", кейіннен бас тарту шартты түрде-мерзімінен бұрын жазаны өтеуден босату соттардың көрсетіледі тұрақсыз мінез-құлық болмауы, мінез-құлық дәрежесі, саны аз көтермелеу және т.б. бұдан Басқа, сот негізделеді ғана мәліметтер ұсынылған мекеменің әкімшілігі сотталғандардың, бұл біздің ойымызша, сипатқа ие және болып табылады жеткілікті мәселені шешу үшін шартты түрде мерзімінен бұрын босату. Осыған байланысты туралы қорытындыны түзету сотталған және қолдану мүмкіндіктерін, оған қатысты шартты түрде мерзімінен бұрын босатуға ұсыну қызметкерлеріне, пробациялық бақылауды жүзеге асыратын осы мекемеде. Содан кейін сот материалдарын зерделеп, пробация қызметтері мен мекеменің әкімшілігі, тиісті шешім қабылдайды.

**Түйін сөздер:** пробациялық бақылау шартты түрде-мерзімінен бұрын босату, пенитенциарный бақылау, сотталған адамның түзелуіне, әлеуметтік бейімдеу сотталған адамның ресолициация сотталушының, сотталған адамның түзелуіне, пробация қызметі.

Р. Н. Ключко<sup>1</sup>, Ғ. С. Джумашев<sup>2</sup>

<sup>1</sup>Заведующий кафедрой уголовного права, уголовного процесса и криминалистики Гродненского государственного университета им. Купала, Республика Беларусь;  
<sup>2</sup>Соискатель кафедры уголовного права Гродненского государственного университета им. Янки Купалы (Республика Беларусь), Астана, Казахстан

### ПРОБАЦИОННЫЙ КОНТРОЛЬ В ОТНОШЕНИИ ЛИЦ, ПОДЛЕЖАЩИХ УСЛОВНО-ДОСРОЧНОМУ ОСВОБОЖДЕНИЮ

**Аннотация.** С 1 января 2015 года уголовно-исполнительные инспекции Комитета уголовно-исполнительной системы Министерства внутренних дел Республики Казахстан были преобразованы в службу пробации с расширением функции по содействию в получении социально-правовой помощи и осуществ-

лением пробационного контроля. В этой связи раскрываются вопросы становления и развития института пробации в Республике Казахстан.

В связи с тем, что значительная часть преступлений среди лиц, условно-досрочно освобожденных из мест лишения свободы, совершается из-за социальных проблем, необходимо в отношении лиц, подлежащих к условно-досрочному освобождению проводить работу по их ресоциализации, как это установлено законодательством в отношении осужденных, отбывающих наказание в виде лишения свободы, которым до отбытия срока наказания остался один год. Кроме того, предполагается расширения применения пенитенциарного контроля в отношении лиц, подлежащих, условно-досрочному освобождению.

В статье также проведен анализ критериев исправления осужденных с позиции факторов, которые влияют на степень снижения общественной опасности лица, с учетом анализа практики правоприменения условно-досрочного освобождения, отечественного законодательства, мнений ведущих юристов – ученых. По результатам данного анализа предложены научно-правовое описание термина «исправление», а также порядка и условий осуществления пробационного контроля.

Проведенный анализ материалов об условно-досрочном освобождении от наказания также свидетельствует о том, что отказывая в удовлетворении ходатайств и представлений, судьи, в основном, мотивируют свое решение совокупностью необходимых обстоятельств, характеризующих личность осужденных. Кроме того, суд основывается только на сведениях, представленных администрацией учреждений на осужденных, что, на наш взгляд, носит формальный характер и является недостаточным для решения вопроса об условно-досрочном освобождении. В этой связи предлагается заключение об исправлении осужденного и возможности применения в отношении него условно-досрочного освобождения предоставить сотрудникам, осуществляющим пробационный контроль в данном учреждении. Тогда суд, изучив материалы служб пробации и администрации учреждения, примет соответствующее решение.

**Ключевые слова:** пробационный контроль, условно-досрочное освобождение, пенитенциарный контроль, исправление осужденного, социальная адаптация осужденного, ресоциализация осужденного, исправление осужденного, служба пробации.

#### Information about authors:

Klyuchko R. N., candidate of law, associate Professor, Head of the Department of criminal law, criminal procedure and criminalistics of the Grodno state University named after ya. Kupala, Republic of Belarus.

Dzhumashev G. S., Applicant for the Department of criminal law of Yanka Kupala Grodno state University (Republic of Belarus), Astana, Kazakhstan; g\_djumashev@mail.ru; <https://orcid.org/0000-0002-8144-3828>

#### REFERENCES

[1] The Law of the Republic of Kazakhstan dated February 15, 2012 “On Amendments and Additions to Some Legislative Acts of the Republic of Kazakhstan on the Probation Service // (electronic resource) <http://adilet.zan.kz/rus/docs/Z1200000556> (date appeals 01.03.2020).

[2] Decree of the Government of the Republic of Kazakhstan dated October 23, 2014, N 1131 “On approval of the Rules for the provision of social and legal assistance to persons registered with the probation service” // (electronic resource) <http://adilet.zan.kz/rus/docs/P1400001131> (accessed date 01.03.2020).

[3] Order of the Minister of Internal Affairs of the Republic of Kazakhstan dated August 15, 2014, N 511 “On approval of the Rules for the organization of activities of the probation service” // (electronic resource) <http://adilet.zan.kz/rus/docs/V14C0009738> .2020).

[4] The Penal Code of the Republic of Kazakhstan dated July 5, 2014, N 234-V ЗПК // (electronic resource) <http://adilet.zan.kz/rus/docs/K1400000234> (accessed 01.03.2020).

[5] The Law of the Republic of Kazakhstan dated December 30, 2016, N 38-VI “On Probation” // (electronic resource) <http://adilet.zan.kz/rus/docs/Z1600000038> (accessed 01.03.2020).

[6] Commentary on the Law of the Republic of Kazakhstan “On Probation”. Kostanay: Kostanay Academy of the Ministry of Internal Affairs of the Republic of Kazakhstan named after S. Kabybaeva, 2017. 240 p.

[7] Skakov A.B. Criminal executive law of Kazakhstan: current status and development prospects // Criminal executive law. 2017. N 3. P. 326-330.

[8] The Criminal Code of the Republic of Kazakhstan dated July 3, 2014. N 226-V // (electronic resource) <http://adilet.zan.kz/rus/docs/K1400000226> (accessed 01.03.2020).

[9] Cossack B. B. Security of the penal system / ed. S.N. Ponomareva, S.A. Dyachkovsky. Ryazan: Academy of Law and Management of the Ministry of Justice of Russia, 2002. 324 p.

[10] Zubkov A.I. The legal significance of the goal of correction of prisoners sentenced to imprisonment // Crime and Punishment. 1998. N 4. P. 37-38.

[11] Shmarov I.V. Prevention of crimes among those released from punishment. M., 1974. 136 p.

**NEWS**

OF THE NATIONAL ACADEMY OF SCIENCES OF THE REPUBLIC OF KAZAKHSTAN

**SERIES OF GEOLOGY AND TECHNICAL SCIENCES**

ISSN 2224-5278

Volume 2, Number 440 (2020), 162 – 169

<https://doi.org/10.32014/2020.2518-170X.44>

UDC 332.12(075.8)

IRSTI: 73.01.73

**Taisarinova Aislu<sup>1,4</sup>, Teltaev Bagdat<sup>2</sup>, Guiseppe Loprensipe<sup>3</sup>, Ibragimova Nailya<sup>4</sup>**

<sup>1</sup>Kazakh Academy of Transport and Communications  
named after M. Tynyshpayev, Almaty, Kazakhstan;

<sup>2</sup>Kazakhstan Highway Research Institute, Almaty, Kazakhstan;

<sup>3</sup>Sapienza University, Rome, Italy;

<sup>4</sup>German Kazakh University, Almaty, Kazakhstan.

E-mail: taisarinova@gmail.com, bagdatbt@yahoo.com,  
giuseppe.loprencipe@uniroma1.it, nailya.73@mail.ru

**ANALYSIS OF ENTERRELATION BETWEEN ECONOMIC,  
ROAD, TRANSPORT AND LOGISTIC INDICATORS**

**Abstract.** The purpose of this research is to identify interrelation analysis between economic, road, transport and logistics indicators. Retrospective research of the freight turnover dynamics was conducted, as well as roads length, number of transport companies and the Gross National Product (GDP) from 1993 to 2017 in the Republic of Kazakhstan. For transport field freight turnover was chosen as economic indicator, for logistics service - the number of transport companies and the length of the motorway - for the infrastructure development. The qualitative analysis of the condition of the road surface showed unevenness of the infrastructure development along the corridor. It was revealed that the increase of freight turnover and the number of companies lead to the growth of the regional economic indicator GDP. However, the transport criteria are significantly lagging behind of the GDP growth rate. The lag was caused by the prolonged period of logistics infrastructure formation. Given the positive dynamics at the time of the route launch, it can be assumed that the development of regional economics is associated with the process of region integration into the international transport system, where the corridor «WE-WC» can be one of integration mechanisms.

**Key words:** Gross national product (GDP), cargo turnover, road length, regional logistics indicator, international transport corridor "Western Europe-Western China."

**Introduction.** Due to the increasing globalization and the strengthening of the labor division process, logistics, as an integration management system, began to increase its strategic position in economic development of the region [1]. In these circumstances, new practices management are needed at the local level [2]. We can assert that the identification of the main mechanisms of interaction between the economy and logistics at the regional level can reflect the current state of development of the regions of the republic and predict their future [3].

Thus, logistics can influence the state and growth of the regional economy, optimize existing economic relations, promote the formation of new industries and agriculture.

International transport corridors can be seen as a means of economic development of the region, within the geographical area, and stimulation of national economic growth through the infrastructure development [4]. With the launch of transit corridors, the procedures of trade, people movement, goods and services, as well as the investment climate, are simplified. The development of corridors involves modernization and development of transport routes that physically connect the regions [5,6].

The geography of world trade shift towards Asia [7]. One of the largest projects on the Asian-European continent is the international project "Belt Road Initiative"[8], which brings together 126 participating countries [9], which account for 46% of world trade and about 38.5% of world GDP [10,11]. Part of the BRI initiative is the "Western Europe - Western China" (WE - WC) transport corridor,

which goes from China to Europe through Kazakhstan [12]. At the same time, the five regions of the Republic of Kazakhstan (Turkestan, Almaty, Jambyl, Kyzylorda and Aktobe), that are involved in the WE - WC transit corridor system, differ in the level of their economic development. The issue of how regions plan to cope with the freight volumes is still unclear. On the other hand, significant turnover growth requires verification [13].

The purpose of this research is to identify interrelation analysis between economic, road, transport and logistics indicators.

**Research methods.** Several factors were analyzed such as the long-term dynamics of cargo turnover, the length of roads, the number of transport companies and GDP for the period 1993-2017. The official data of the Statistics Committee of Kazakhstan Ministry of National Economy were the source for the analysis [13]. The following mathematical and statistical methods were used: regression analysis and evaluation of changes by means of determination and approximation usage.

**Results.** Figure 1 shows a consolidated description of roads development, located in the areas along the WE-WC corridor [14]. Thus, 37% of Kazakhstan part of the international transport corridor goes through the territory of Jambyl region, 32% - Kyzylorda, 23% - Aktobe, 18% - Almaty and about 12% - Turkestan. Despite of the fact that the largest share of the road length in KZ belongs to Almaty region and makes up to 36.4% of the total road length of the republic, in terms of quality it ranks last among the areas involved in the international transport corridor called WE-WC. The highest density per square kilometer is observed in Turkestan region that is 54.3%. Heterogeneity of road density of all the five regions, that constitute the international transport corridor, is observed on the figure 1. This fact proves unbalanced development of road and transport infrastructure in the regions of the Republic of Kazakhstan.

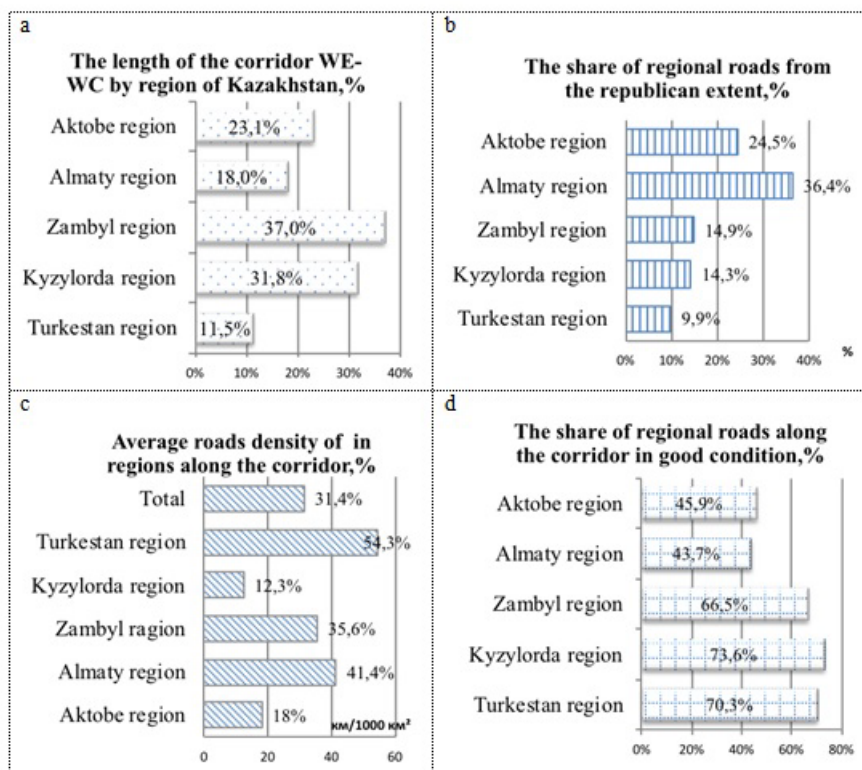

Figure 1 – Transport characteristics of roads involved in the international transport corridor «WE-WC» [15]

As you know, one of the indicators of region economic development and the national economy as a whole is the freight turnover, that in turn is influenced by fluctuations of GDP. See figure 2, that shows the rate of GDP growth and freight turnover from 1993 to 2017.

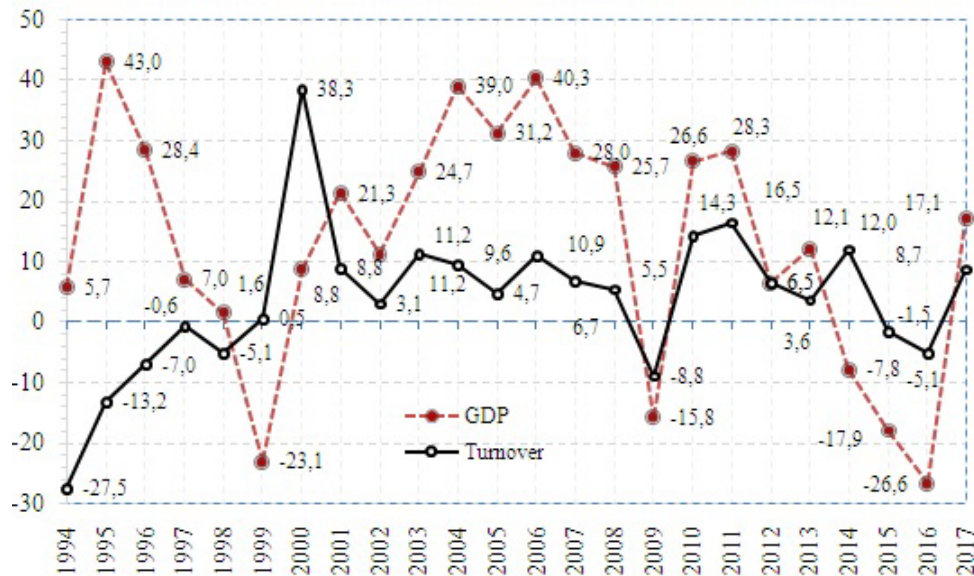

Figure 2 – GDP and turnover growth rates in the Republic of Kazakhstan, 1993-2017

In the early stages of economic development of sovereign Kazakhstan (1993-1998), freight traffic and GDP development had contradictory behavior. Between 1995 and 1998, freight turnover had been recovering by an average of 7.2% annually. Over the next 10 years, both freight turnover and GDP behaved synchronously and their indicators develop with close change per cent age (GDP on average 11.2%, cargo turnover 8.1%).

Clearly marked two crisis periods of 1999 and 2009 coincide with the periods of world economic crises. In 1999 there was a sharp drop of GDP to -23.1% and a decrease in freight turnover up to -5.1%, whereas in 2009 GDP fell down to -15.8% with freight turnover at -7.8%.

Since 2010, the growth rate of freight traffic has been slowing, it was lower than the GDP growth rate. The level of GDP has increased by 41.2% and the freight turnover - by 34.6% during these 7 years, i.e. approximately 1% of freight turnover growth accounts for 1% of GDP growth (figure 2).

Figure 3 shows a correlation between GDP and road transport turnover between 1993 and 2017. According to the analysis, there is a direct correlation between GDP and freight turnover, here the rate of determination R<sup>2</sup> is equal to 0.94.

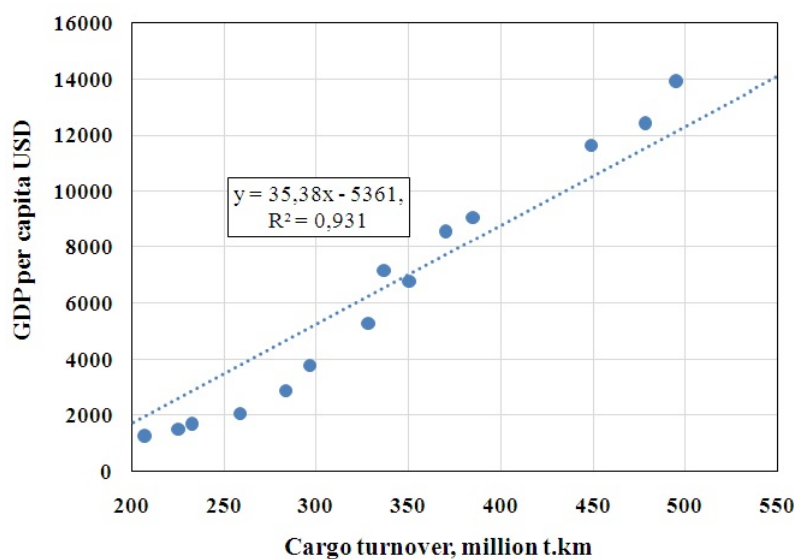

Figure 3 – Correlation between GDP and freight turnover in the Republic of Kazakhstan, 1993-2017

GDP growth is accompanied by an increase in freight turnover, however, the growth rate of the transport industry lags behind. In general, the turnover acts as a sensitive marker of the country macroeconomic development, which is initiated or reduced due to the development of the transport industry.

Figure 4 shows the rate of GDP growth and the road length in the Republic of Kazakhstan. It is evident that the level of GDP does not lead to significant changes in the length of roads.

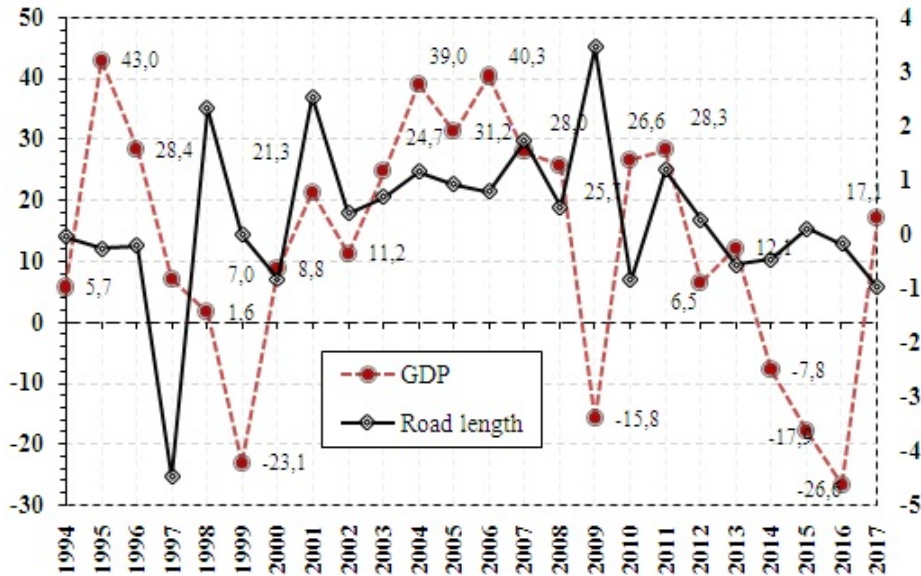

Figure 4 – The growth rate of GDP and the length of roads in the Republic of Kazakhstan, 1993-2017

Although the interdependence between GDP growth and road length is weak, there is a sufficiently close correlation between these indicators ( $R^2 = 0,939$ ), which can relate to the international transport corridor "WE-WC" impact (figure 5).

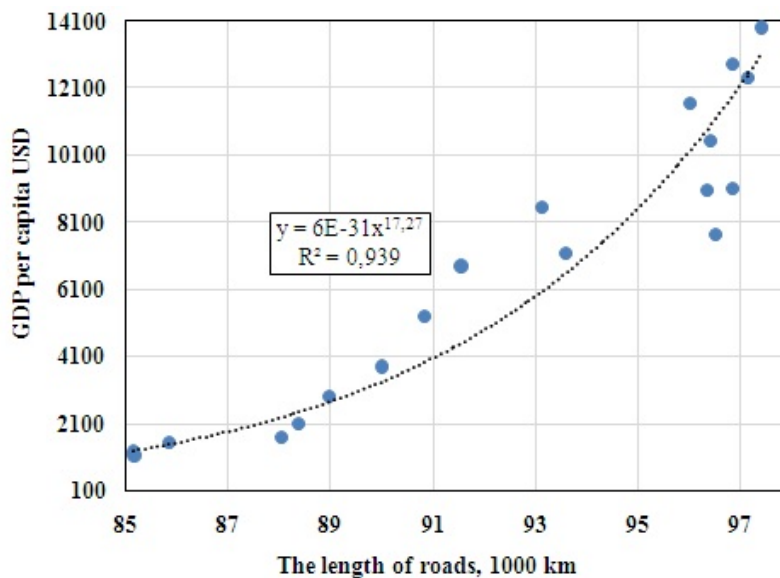

Figure 5 – The correlation between GDP and the long-distance roads in the Republic of Kazakhstan, 1993-2017

In studying the dependence of GDP on the number of companies engaged in the transport industry, companies with vehicles and storage facilities were taken into account. Since 2000, there has been a direct correlation between the increase in GDP and the number of companies however, their growth rate lags slightly behind GDP growth, for example, from 2.2 to 4.7% by 2007 (figure 6). The growth of transport companies, which may be due to the operation of the international transport corridor "WE-WC" (figure 6).

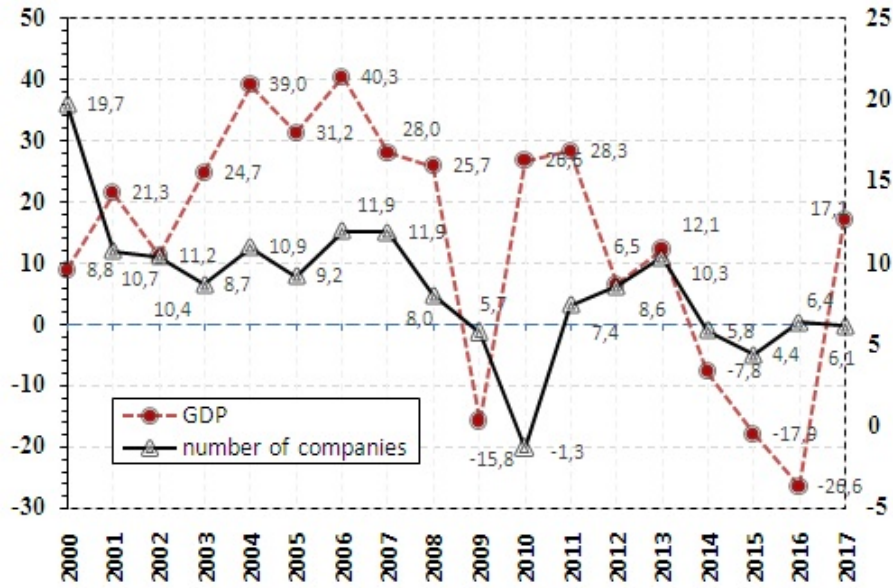

Figure 6 – GDP growth rates and the number of transport companies in the Republic of Kazakhstan, 1993-2017

Figure 7 shows the correlation between GDP and the number of transport companies in the Republic of Kazakhstan.

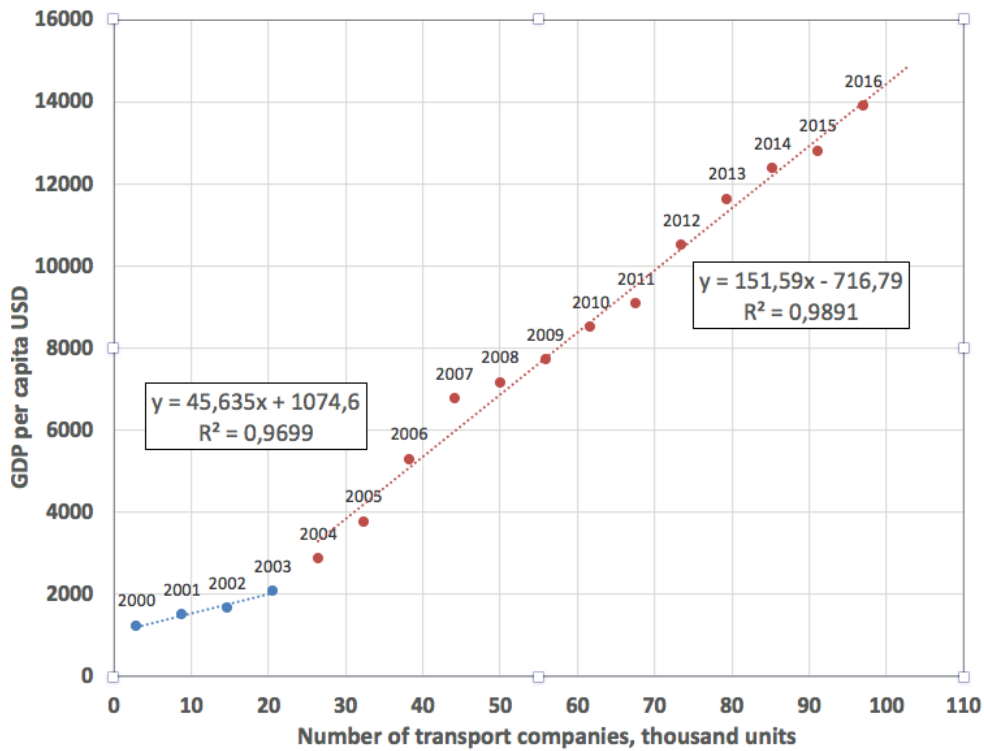

Figure7 – Correlation between GDP and the number of transport companies in the Republic of Kazakhstan, 1993-2017

The strength analysis of the link between the GDP and number of transport companies revealed tipping point in 2003. From 2000 to 2003 years, the relationship is quite pronounced and can be described by  $y=45.635x+1075.6$  dependence. From 2004 to 2017 years relation changed to  $y=151.59x-716.79$  dependence. We believe that this change is connected with change in transport and road infrastructure which in turn influenced the formation of a logistical regional system.

**Conclusion.** As a result of the statistical analysis between GDP, freight turnover, roads length and the number of companies operating in the transport industry, was established:

- growth of the regional economy stimulates increase the freight turnover and the number of companies in the transport industry;
- the rate of freight turnover response to GDP outpace rate roads length changes, which significantly hinders the reaction of the transport sector;
- road infrastructure development in 5 (Aktobe Kyzylorda, Zhambyl, Turkestan, Almaty) WE-WC corridor region is heterogeneous;
- the correlation between GDP and the number of companies employed in the transport industry revealed two periods from 2001-2003, and 2012-2017. In 2001 was approved the program of road industry development, in 2012 initiated the international "WE -WC" project. Restructuring caused by corridor has had a sensitive impact to logistics change, in our case expressed in the number of transport companies.

Consequently, improving of region economic climate generate a new logistical links, that help regional producers are finding new distribution channels. According to the analysis, the growing of a regional logistics system along the corridor can push the economic development of Kazakhstan oblasts. Accordingly, essential to established the indicators describing of regional logistics system development and include them in strategic development plan.

**А. С. Тайсарина<sup>1,4</sup>, Б. Б. Телтаев<sup>2</sup>, Д. Лопренчипе<sup>3</sup>, Н. А. Ибрагимова<sup>4</sup>**

<sup>1</sup>М. Тынышпаев атындағы Қазақ көлік және коммуникациялар академиясы, Алматы, Қазақстан;

<sup>2</sup>«Қазақстан жол ғылыми-зерттеу институты» акционерлік қоғамы, Алматы, Қазақстан;

<sup>3</sup>«Сапиенса университеті», Рим, Италия;

<sup>4</sup>«Қазақстан неміс университеті», Алматы, Қазақстан

### **ЭКОНОМИКАЛЫҚ, АВТОМОБИЛЬ ЖОЛЫ, КӨЛІК ЖӘНЕ ЛОГИСТИКАЛЫҚ КӨРСЕТКІШТЕР АРАСЫНДАҒЫ ӨЗАРА БАЙЛАНЫСТЫ ТАЛДАУ**

**Аннотация.** Зерттеудің мақсаты экономика, автомобиль жолдарының ұзындығы, көлік және логистика көрсеткіштері арасындағы өзара байланысты анықтау болып табылады.

«Belt Road Initiative» BRI жобасын өз уақытының белгілі және ауқымды жобаларының бірі деп санауға болады. Егер оған әлемдік сауданың 46%-ы және әлемдік ЖІӨ-нің шамамен 38,5% - ы 126 қатысушы ел енегінін назарға алсақ, таяу жылдары ол әлемдік сауда орталығын алмастыра алады деп айтуға болады. BRI бастамасының бір бөлігі Қытайдан Еуропаға Қазақстан арқылы өтетін "Батыс Еуропа – Батыс Қытай" көлік дәлізі (БЕ-БК) болып табылады. Сонымен қатар, (БЕ-БК) транзиттік дәліздер жүйесіне қатысатын, бір-бірінен өзінің экономикалық даму деңгейімен айтарлықтай ерекшеленетін Қазақстан Республикасының бес өңірі (Түркістан, Алматы, Жамбыл, Қызылорда және Ақтөбе). Аймақтардың жүк тасымалының көлемін орындап шығуын жоспарлауы әзірге түсініксіз болып тұр. Екінші жағынан, тауар айналымының айтарлықтай өсуі де тексеруді талап етеді.

Қазақстан Республикасында 1993 жылдан бастап 2017 жылға дейін жүк айналымының серпініне, сондай-ақ, жолдардың ұзындығына, көлік компанияларының санына және жалпы ішкі өнімге (ЖІӨ) ретроспективті зерттеу жүргізілді. Тасымалдауды сипаттау үшін жүк айналымы таңдалды. Логистикалық сервис көрсеткіші ретінде көлік компанияларының саны пайдаланылды. Автомагистральдың ұзындығы инфрақұрылымдық дамудың көрсеткіші ретінде таңдалды. Жол жамылғысының жай-күйін сапалы талдау дәліз бойындағы инфрақұрылымның біркелкі дамымағанын көрсетті. Жүк айналымы мен компаниялар санының артуымен ЖІӨ экономикалық көрсеткіштерінің өсуі байқалады. Алайда көлік критерийлері ЖІӨ өсу қарқынынан айтарлықтай артта қалып отыр. Артта қалу логистикалық инфрақұрылымды қалыптастырудың ұзақ кезеңінен туындады. Бағытты іске қосу сәтіндегі оң динамиканы ескере отырып, аймақтық экономиканың дамуы «Батыс Еуропа-Батыс Қытай» дәлізі (БЕ-БК) интеграциялық тетіктердің бірі бола алатыны аймақтардың халықаралық көлік жүйесіне кірігу үрдісімен байланысты деп болжауға болады.

Көлік саласында жұмыс істейтін компаниялар саны мен жол ұзындығы, жүк айналымы, ЖІӨ статистикалық талдауының нәтижесінде:

- аймақтық экономиканың өсуі жүк айналымын және көлік саласындағы компаниялар санын арттыруды ынталандырады;
- ЖІӨ-ге жүк айналымының әсер ету қарқыны жол ұзындығының өзгеру қарқынын басып озуда, бұл көлік секторының реакциясын елеулі қиындатады;

– (БЕ-БК) дәлізінің 5 аймағында (Ақтөбе Қызылорда, Жамбыл, Түркістан, Алматы) жол инфрақұрылымының дамуы біркелкі емес;

– ЖІӨ мен көлік саласында жұмыс істейтін компаниялар саны арасындағы корреляция екі кезенді 2001-2003 және 2012-2017 анықтады. 2001 жылы жол саласын дамыту бағдарламасы бекітілді, 2012 жылы (БЕ-БК) халықаралық жобасы бастау алды. Дәлізден туындаған қайта құрылымдау, біздің жағдайда, көлік компаниялары санымен айқындалатын логистиканың өзгеруіне елеулі әсер етті.

Демек, аймақтағы экономикалық климаттың жақсаруы аймақтық өндірушілерге сауда жасаудың жаңа арналарын табуға көмектесетін логистикалық байланыстар құрады. Талдауға сәйкес, дәліз бойында аймақтық логистикалық жүйені дамыту қазақстандық облыстардың экономикалық дамуын арттыра алады. Сәйкесінше, аймақтық логистикалық жүйенің дамуын сипаттайтын көрсеткіштерді белгілеу және оларды стратегиялық даму жоспарына енгізу қажет.

**Түйін сөздер:** жалпы ішкі өнім (ЖІӨ), жүк айналымы, автомобиль жолдарының ұзындығы, логистиканың аймақтық индикаторы, «Батыс Еуропа-Батыс Қытай» халықаралық көлік дәлізі.

**А. С. Тайсарина**<sup>1,4</sup>, **Б. Б. Телтаев**<sup>2</sup>, **Д. Лопренчипе**<sup>3</sup>, **Н. А. Ибрагимова**<sup>4</sup>

<sup>1</sup>Казахская Академия транспорта и коммуникаций им. М. Тынышпаева, Алматы, Казахстан;

<sup>2</sup>АО «Казахстанский дорожный научно-исследовательский институт», Алматы, Казахстан;

<sup>3</sup>«Сапиенса университеті», Рим, Италия;

<sup>4</sup>«Казахстанско-Немецкий университет», Алматы, Казахстан

#### **АНАЛИЗ ВЗАИМОСВЯЗИ МЕЖДУ ЭКОНОМИЧЕСКИМИ, АВТОМОБИЛЬНЫМИ, ТРАНСПОРТНЫМИ И ЛОГИСТИЧЕСКИМИ ПОКАЗАТЕЛЯМИ**

**Аннотация.** Целью данного исследования является выявление взаимосвязи между показателями экономики, автомобильных дорог, транспорта и логистики.

Одним известных и масштабных проектов своего времени можно считать BRI “Belt Road Initiative”. Если принять во внимание, что в него входит 126 стран-участниц, на которые приходится 46% мировой торговли и около 38,5% мирового ВВП, то можно утверждать, что в ближайшие годы он способен сместить центр мировой торговли. Частью инициативы BRI является транспортный коридор «Западная Европа – Западный Китай» (ЗЕ-ЗК), который проходит из Китая в Европу через Казахстан. В то же время пять регионов Республики Казахстан (Туркестан, Алматы, Жамбыл, Кызылорда и Актөбе), которые участвуют в системе транзитных коридоров (ЗЕ-ЗК), значительно различающихся друг от друга уровнем своего экономического развития. Вопрос о том, как регионы планируют справиться с объемами грузоперевозок, пока остается неясным. С другой стороны, значительный рост товарооборота так же требует проверки.

В частности, было проведено ретроспективное исследование динамики грузооборота, протяженности дорог, количества транспортных компаний и валового национального продукта (ВВП) с 1993 по 2017 года в Республике Казахстан. Для описания перевозки был выбран грузооборот. В качестве индикатора сервисной логистики использовалось количество транспортных компаний. Протяженность автомагистрали была выбрана в качестве индикатора развития инфраструктуры. Качественный анализ состояния дорожного покрытия показал неравномерность развития инфраструктуры вдоль коридора. Выяснилось, что с увеличением грузооборота и количества компаний наблюдается рост экономических показателей, выраженных в ВВП. Однако транспортные критерии значительно отстают от темпов изменения ВВП. Отставание вызвано длительным периодом формирования логистической инфраструктуры. Учитывая положительную динамику на момент запуска маршрута, можно предположить, что развитие региональной экономики связано с процессом интеграции в международную транспортную систему. Связующим звеном такой интеграции может стать коридор "Западная Европа - Западный Китай" (ЗЕ-ЗК).

В результате статистического анализа ВВП, грузооборота, протяженности дорог и количества компаний, работающих в транспортной отрасли, было установлено:

– рост региональной экономики стимулирует увеличение грузооборота и количества компаний в транспортной отрасли;

– темпы реагирования грузооборота на ВВП опережают темпы изменения длины дорог, что существенно затрудняет реакцию транспортного сектора;

– развитие дорожной инфраструктуры в 5 (Ақтөбе, Қызылорда, Жамбыл, Түркістан, Алматы) регионах коридора (ЗЕ-ЗК) является неоднородным;

– корреляция между ВВП и числом компаний, занятых в транспортной отрасли, выявила два периода 2001-2003 и 2012-2017. В 2001 году была утверждена программа развития дорожной отрасли, в 2012 году инициирован международный проект (ЗЕ-ЗК). Реструктуризация, вызванная коридором, оказала чувствительное влияние на изменение логистики, в нашем случае выраженное в количестве транспортных компаний.

Следовательно, улучшение экономического климата в регионе создает логистические связи, которые помогают региональным производителям находить новые каналы сбыта. Согласно анализу, развитие региональной логистической системы вдоль коридора может подтолкнуть экономическое развитие казахстанских областей. Соответственно, необходимо установить показатели, описывающие развитие региональной логистической системы, и включить их в стратегический план развития.

**Ключевые слова:** валовой национальный продукт (ВВП), грузооборот, длина дороги, региональный индикатор логистики, международный транспортный коридор «Западная Европа-Западный Китай».

#### Information about authors:

Taisarinova Aislu, Phd researcher, teacher of Kazakh German University, Kazakh Academy of Transport and Communications named M. Tynyshepayev; taisarinova@gmail.com; <https://orcid.org/0000-0002-2348-009X>

Teltayev Bagdat Burkhanbaiuly, Doctor of Technical Sciences, Professor, President of JSC “Kazakhstan Highway Research Institute”; bagdatbt@yahoo.com; <https://orcid.org/0000-0002-8463-9965>

Giuseppe Loprencipe, Doctor of Technical Sciences, Professor, Sapienza University of Rome, giuseppe.loprencipe@uniroma1.it; <https://orcid.org/0000-0003-1003-8849>

Ibragimova Nailya, Doctor of biological science, Kazakh German University; nailya.73@mail.ru; <https://orcid.org/0000-0002-1618-900X>

#### REFERENCE

[1] Kajal L., Yao W., 2012. Should Transportation output be included as part of the coincident indicators system. *Journal Cycle Measurement and Analysis*, 1. P. 1-24 (in Eng.).

[2] Niyzbekova R.R., Yessirkepova A.M., Aliyeva Zh. T., Jawoeska M. Typology of small cities in the South Kazakhstan region // *Bulletin of the National Academy of Sciences of the Republic of Kazakhstan*. ISSN 1991-3494. Vol. 1, N 372 (2018). P. 23–31 (in Eng.).

[3] <http://mfa.gov.kz/ru/bern/content-view/strategia-kazahstan-2050-12>

[4] Nazarko J, Kuźmicz KA, Czerewacz-Filipowicz K. The New Silk Road – Analysis of the potential of new Eurasian transport corridors. (in Eng.).

[5] Rikard Engström, 2016. 6th Transport Research Arena April 18-21, Transportation Research Procedia The roads' role in the freight transport system 14, 2016. P. 1443–1452 (in Eng.).

[6] Chan M.H.T. The Belt and Road Initiative – The New Silk Road: A research agenda. *J. Contemp. East Asia Stud.* 2018, 7, 104–123 (in Eng.).

[7] Panzabekova A., Kolbayev M., Nyurlikhina G., Velesco S. Current trends of direct foreign investment in the world // *Bulletin of National Academy of Sciences of the Republic of Kazakhstan*. ISSN 1991-3494. Vol. 4, N 380 (2019). P. 201–207 (in Eng.).

[8] Li Y., Schmerer H.J. Trade and the New Silk Road: Opportunities, challenges, and solutions. *J. Chin. Econ. Bus. Stud.* 2017, 15, 205–213 (in Eng.).

[9] Yuee Gao, Yaping Zhanga, Hejiang Lia, Ting Penga, Siqi Haoa, Study on the Relationship Between Comprehensive Transportation Freight Index and GDP in China *Procedia Engineering* 137, 2016. P. 571–580 (in Eng.).

[10] Zhang One Belt, One Road: A Chinese View // *Global Asia*. 2015. Vol. 10, N 3. 8 p. (in Eng.).

[11] Li Yongquan The greater Eurasian partnership and the Belt and Road Initiative: Can the two be linked? *Journal of Eurasian Studies* 9, 2018. P. 94–99 (in Eng.).

[12] <https://www.europe-china.kz/info/86>

[13] Naribayev M. The economic belt of the Silk Road: opportunities and risks for Kazakhstan // *Bulletin of National Academy of Sciences of the Republic of Kazakhstan*. ISSN 1991-3494 Vol. 6, N 376 (2018). P. 188–191 (in Eng.).

[14] [http://stat.gov.kz/faces/homePage/homeDinamika.pokazateli?\\_afzLoop=4153874997908858#%40%3F\\_afzLoop%3D4153874997908858%26\\_adf.ctrl-state%3Dmc4k2yyy8\\_37](http://stat.gov.kz/faces/homePage/homeDinamika.pokazateli?_afzLoop=4153874997908858#%40%3F_afzLoop%3D4153874997908858%26_adf.ctrl-state%3Dmc4k2yyy8_37)

[15] <https://www.stat.gov.kz/>

**NEWS**

OF THE NATIONAL ACADEMY OF SCIENCES OF THE REPUBLIC OF KAZAKHSTAN

**SERIES OF GEOLOGY AND TECHNICAL SCIENCES**

ISSN 2224-5278

Volume 2, Number 440 (2020), 170 – 177

<https://doi.org/10.32014/2020.2518-170X.45>

UDC 528; 551.4

**S. A. Tarikhazer**

Institute of Geography of ANAS, Baku, Azerbaijan.

E-mail: kerimov17@gmail.com

**MORPHOMETRIC ANALYSIS OF THE RELIEF  
OF THE NORTH-EASTERN SLOPE OF THE GREAT CAUCASUS  
FOR THE PURPOSE OF TOURISM POTENTIAL  
(using GIS technologies)**

**Abstract.** Considering that to date, the scientific, theoretical and methodological basis of the use of GIS technologies in tourist geomorphology is not sufficiently developed, the article carried out a morphometric study of the north-eastern slope of the Greater Caucasus in order to develop tourism. The morphometric analysis of the study area we carry out with using a digital relief model (DEM) using the ArcGIS package. The initial data were the results of a Shuttle radar topographic mission (SRTM) radar survey, designed to create a high-precision network of global DEM. Its root-mean-square error is estimated at a height of about 16 m, and the clarity of the position of the nodes of the three-second grid is about 20 m, while in conditions of mountainous relief these indicators become larger. An SRTM image with a resolution of approximately 60 m is useful for implementing morphometric analysis and creating proper maps in a GIS. Image editing related to identification and elimination of minor errors was performed using the ArcGIS package and its Spatial Analyst module.

To establish the general background of the fragmentation of the modern relief, a 5-point scale for assessing morphometric tension was developed and adopted, which includes the degree of horizontal and vertical fragmentation of the territory, the decline of the slopes, etc. The results can be used to create investment projects for the development of tourism on the north-eastern slope of the Greater Caucasus.

**Key words:** tourism, morphometric analysis, morphometric tension, exogenous processes, ecogeomorphological region, danger, GIS technologies.

**Introduction.** One of the fastest developing fields in the world in economy is tourism at the moment. In the scope of Azerbaijan tourism is considered as one of the most demanded field as a new form of property for our republic. It is worth to emphasize that having high economic potential, tourism is promoting development of other mixed fields of economy: transport, trade, communication, production of goods of wide consumption, agriculture and etc. Expansion of range of fields in this sector has a number of positive moments, however, the absence of scientific based methodology and corresponding control is definitely reflected in condition of natural environment. Implementation of tourism activities is obliged to be in line with the current legislation in the field of protection of natural environment, and it is important to pursue corresponding scientific based evidences taking into account certain territory in order to be in line with this or other types of tourism and recreation [1]. The given system is consisted of several parts where among them the formation of system of environmental geomorphological criteria which is discovering the landscape, tourism zoning of the territory and identification of level of environmental risk [2].

We think that the morphometric analysis of landscape of the territory is the main element of similar studies which can provide an opportunity to evaluate geomorphological touristic resources of North Eastern slope of the Greater Caucasus.

**Materials and methodology of study.** In Geomorphological achievements they have been analyzed as the main features of the landscape, which can allow us to assess the landscape to which we can include: morphometrics (morphology), dynamic, genesis and age that is also divided to approximately specific

features (the absolute and comparative height, angle of slopes, vertical and horizontal distribution, exposition of slopes and etc.). The above mentioned morphometric condition of accelerated ecogeomorphological state can impact on different level [3,4]. Position and hypsometry of slopes are influencing to ecogeomorphological situation through macro and climate conditions. Horizontal distribution is characterizing the level of differentiation of ecogeomorphological conditions in the spaces, the repeating of slopes of frontal exposition, periods of reformation of landscape complexes. In development ecogeomorphological condition the angles of surface of slopes are defining energy of landscape, activeness and speed of slope processes, also influence to physical, chemical and mechanical features of soil surface, development and productivity of plants, to amount of solar radiation, infiltration of atmosphere precipitations, transformation of energy and elements and other processes which in different levels can impact to organization of landscape complexes and ecosystems [5,6].

Morphometrics is putting certain objectives which are formulating the group of tasks: 1. Description of landscape 2. Explanation of landscape 3. Forecast of formation of landscape [7,8].

One of the important problems for north eastern slope of Great Caucasus which is traditionally used for recreation and tourism is evaluation and appropriate application of tourism resources. Especially important in this issue is the task of evaluation of psychological esthetic features of landscape, which are contributing to strengthening moral and physical state and potential of population [9].

To our opinion, it is desirable to use AKS, air photo plans and photographic maps and sometimes their applications for studying geometry of slopes. The advantage of AKS is that in with them possible to see in details the boundaries of slopes of mountainous territories than in topographic maps. Having forest cover AKS is less informative than topographic maps. That's why it is better to identify the regions where desirable AKS can be applied and where is better to use topographical map [6].

The morphometric analysis of north eastern slope of Greater Caucasus had been conducted by us with the help of digital elevation model (DEM) through using their ArcGIS package. Baseline data were used as a result of radio location shot of shuttle radar topographic mission (SRTM) considered for creation of high resolution network of global DEM. The average square error of it is evaluated on the height approximately equal to 16 meters and resolution of state of three second cell is around 20 meters with the fact that in condition of mountainous landscape the data is becoming higher or larger. SRTM with the resolution approximately 60 meters is useful for realization of morphometric analysis and development of corresponding maps in GIS. Editing image related with identification and eradication of insignificant errors had been conducted with the help of the package ArcGIS and its model Spatial Analyst [10]. The map of angles of slopes of surface of ground (drastic slopes) had been developed by us using the function of Spatial Analyst and its option of surface analysis (figure 1).

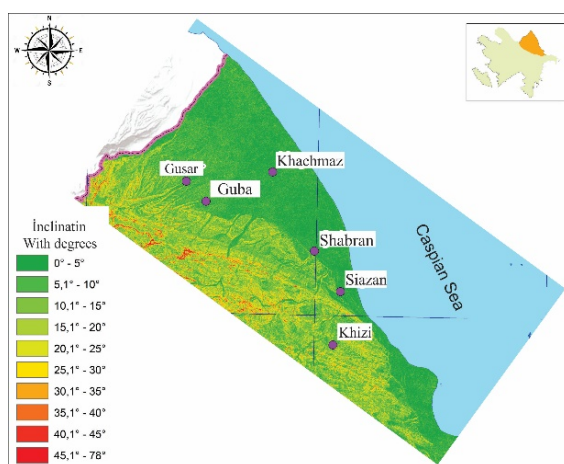

Figure 1 – The map of tilt angles

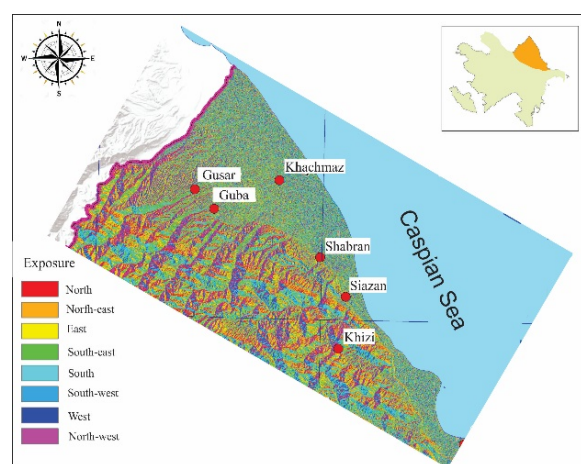

Figure 2 – The map of slope exposure

Initially the map was presented in raster format and later it was converted to vector format. In conclusion there had been developed the polygons of various drastic slopes of vector format maps with angles of slopes. Initially there had been created a hypsometric map with identified elevation levels, then there was calculated maximum and minimum sizes of slopes as well as squares of polygons on elevation

level [7]. At the same place with the same methodology on the bases of digital elevation model there was developed maps of exposition of slopes (figure 2), maps of horizontal and vertical breakdowns (figure 3, figure 4). There had been applied to them geometrical layers such as geological (lithology of rocks), hydrographic network, climate parameters (humidity, atmospheric precipitation, temperature etc.).

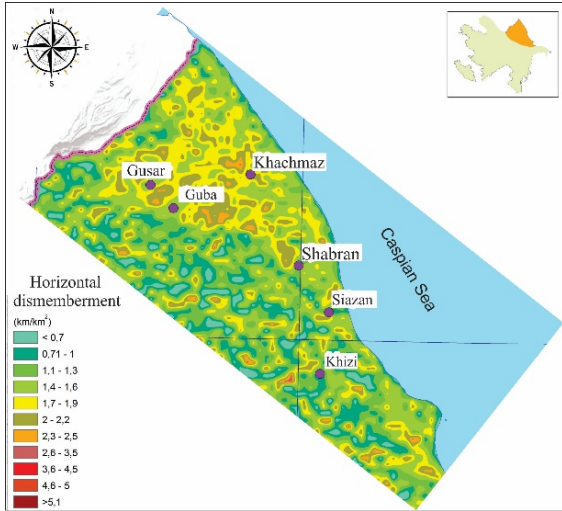

Figure 3 – The Map horizontal partition

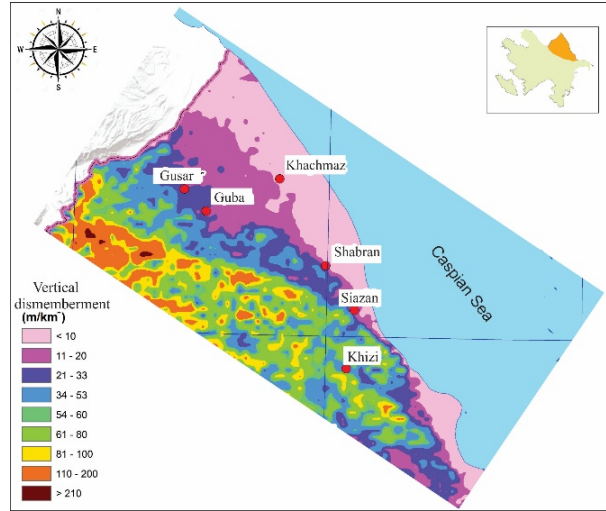

Figure 4 – The map of vertical partition

There had been used by us LANDSAT 8 ASTER GLOBAL DEM (DEM files) on development of maps dated to October 17, 2011 and KS. The works had been conducted in UTM\_WGS\_1984\_UTM\_Zone\_39N coordination system (Universal Transverse Mercator Coordinate System). There had been conducted analysis using the software ArcGIS 10.5, on the basis of which had been created corresponding maps. One to another had been applied the maps of vertical and horizontal distribution with the help of ArcGIS software (tool boxes) and waited overlay functions, map of angles of slopes, where at the end had been achieve the map of morphometric acceleration (figure 5).

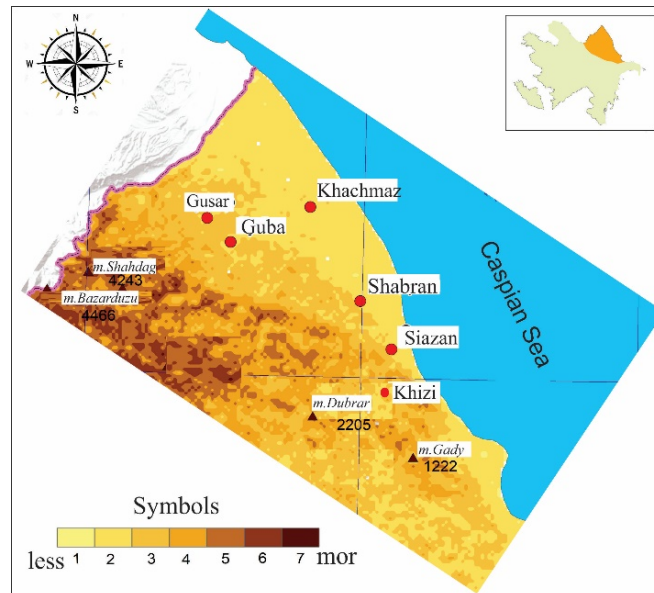

Figure 5 – The map of morphometric tension

With the aim to identify the general background of division of existing landscape there had been developed and accepted 5 scale assessment gradation of morphometric tension (table 1).

Table 1 – Morphometric tension rating scale

Vertical partition (m)	Tilt angles (°)	Horizontal partition (km/m <sup>2</sup> )	Scoring in points
>1000	>40	>2,5	V
500-1000	30-40	1,5-2,5	IV
200-500	20-30	1-1,5	III
100-200	10-20	0,5-1	II
0-100	<10	<0,5	I

The calculation of slope is required for evaluation of group of slope processes and it has to be taken in to account in engineering geomorphological studies and etc. Exposition of slope is expressing its relation to processes oriented trough space in equal schedule (insolation, circulation, gravitation): in analysis of interaction directed to lithological, hydrological, geochemical, and aerodynamic flows to landscape differentiation (direct and indirect impact to exogenic processes, sand formulation, plant cover and etc.). The orientation of slopes to influences of erosion denudation activities is characterizing the morphological features of land cover [7].

**The results of studies.** Mountain geo-system of North eastern slope of Great Caucasus is characterized with intensive breakdown of landscape and they are different on their height, energetic capacity of formation of dangerous fluvioglacial, gravitation, erosion and other landscape forming processes. In given zone it is possible to mention horizontal movement through active disjunctive dislocation of rocks with different genesis and ages. The north eastern slope is characterized with high seismological activeness (7,8 points). Seismological dislocation had enormous impact to development of modern landscape. General tension of horizontal processes in Alpine period of formation of mountains in Great Caucasus in general and in studied region particularly identified in current period with intensive differentiated movements of geodynamic tensions. Multi – character and multi – vectoral alinements conditioned the space distribution and defined the boundaries of morphologically clearly identified steps morpho - structure of given territory. Through these alinement active dynamic zones (Main Caucasus, Siyazan Samur, Valvalichay, Garabulag etc.) is possible to characterize the intensive developing and exogenic landscape formulating processes with high differentiation [11].

The studied territory is divided into following ecogeomorphological regions taken into account the above mentioned data:

Main differentiated massive, Shahdag - Gizil Gaya massive, Tengi - Besh Barmagh massive, Gonagkend - Khaldan series of inter mountain lowlands, Gusar lowland and Samur Davachi lowland. Each of those emphasized ecogeomorphological regions is in line with specific package of tourism resources.

The main Threshold massive is in line with Tufan anticlinoleum where it is consisted of Jurassic clay rocks, sand, limestone which is easily influenced with intensive freeze and physical impact of winds. Landslides and other processes are actively developed in Jurassic slopes of mountains. Also there can be observed soly-fluctuation and defluctuation processes. Main Threshold massive has a perspective on having different category and complexity (Bazarduzu, Tufandag and other mountains).

Shahdag Gizilgaya massive is characterized with the scope of density and depth of disfraction of surface which pre-identified by the intensity modern tectonic movements in line of formation of Samur and Western Caspian transfer zones as well as in a line of their crossing with active Threshold (Siyazan, southern and northern Shahdag, Main Caucasus etc.). Accordingly it is also developed the forms of exervation and modern forms of nivation as well as snow erosion. It has been also distributed the various modern and other types of movements. In drastic slopes it is also distributed mudflows also it is developed deflection and sloifluctuation processes as well as several spaces are occupied with amount flood sources where the areal of them are increased under the influence of technogen factors. Dominating gravitation processes are of different types of land slides and etc. Shahdag-Gizilgaya massive also has a perspective of being included to different category of complexity, and used for skiing sport types (Shahdag mountains, Gizilgaya and others).

The Tengi Besh Barmag massive is consisted of a number of strongly pressured structures among which it is situated similar synclinal zones. The massive is consisted of limestone, clay, sands of various periods and ages. The slopes are drastic and intensively disfracted. The territory has mid mountain and

lowland erosion - denudation landscape. Under the active influence of exomorphodynamic processes the massive is divided through threshold where different forms of landscape are formulated and also there are few waterfalls where is a high land slide risk here which is creating eco geomorphological thred in using the geo-system of given region. Also different types of landslides most developed as well in stone see. Tengi Besh Barmaq massive has a perspective on the point of view of establishment of ecological paths (Velvelechay valley, Laza and Kuzun waterfall and etc.) (figure 6, 7).



Figure 6 – Gorge Velvelechay river



Figure 7 – Laza Waterfall

Gonagkend Khaltan series of inner mountain depression is situated in all high levels and tied different squares of land. High mountainous parts are developed Shahnabat and Khinalig (figure 8) mid mountain and particular low mountain parts Efrin Jimin Gonagkend Altiagaj Khaltan Vostaf Dildilchay Vegver depressions. In depressions of high mountains all the fluvio-glacial erosion denudation and gravitation exodynamic processes are taking place. Also it is widely distributed the landslides and other processes [12]. Gonagkend Khaltan series of inner mountain depressions has a perspective on the point of view ecological paths, agricultural and balneological tourism (Altiagaj, Gonagkend and etc.).



Figure 8 – The road to the Khinalig village

In the Gusar lowland from morphotectonical point of view is in line with the developed deflection which had deflection in the recent stages and since late pleosen it was involved to the general process of escalation of Great Caucasus. Here it is highly distributed landslides which can be consisted of different rocks of scopes of values. Their formation is related with the neogen clay rocks in the basin of rivers Velvelechay, Agchay, Garachay, Gudyalchay.

The landslides also developed in the valleys of the rivers Velvelechay and Gilgilchay. The colorful lithological content of rocks, intensive cut of forests are leading to active formation of the network of sloppy mountains and formation of sources of mudflow and floods. In certain places it is possible to meet clay. The Gusar lowland has a perspective in developing agricultural tourism, horse sport and also gastronomy tourism (Gachres, Chilegir etc.).

Samur-Davachi lowland is consisted of alluvial and alluvial delluvial deposits, it is disfracted with ravines, beans, river values and river beds. It is also developed intensive abrasion processes, abrasion and accumulation processes (cost line sands). Samur-Davachi lowland has a perspective in development of seaside beach tourism, fishery and etc. (Nabran, Yalama, Gilazi, Zarat etc.).

**Conclusions.** From the above mentioned facts it is possible to conclude that morphometric analyses of landscape of north eastern slope of Greater Caucasus through application of GIS is giving an opportunity to conduct quantity assessment of parameters of landscape, e.g. giving appraisal to the level of erosion disfraction, identification of position of slopes, measuring the angles of slopes on earth surface. Besides analysis of multilateral quantity factors of landscape and the developed map of morphometric tension is allowing to reveal the likelihood of opening of conditional type intensity and direction of formation of modern dangerous exogenic processes with the equal scopes and characters of disfraction of landscape, high indicators of which can save the morphometric data. The complex morphometric analysis of the territory through application of GIS are giving opportunity efficiently and in fast way evaluate features of landscape negative features of landscape also for the purposes of forecasting landscape planning. The achieved data can be used and applied not only in several fields of landscape planning (agriculture, land use, construction, environmental activity) as well as in forecasting and functional zoning of territories. The package of morphometric features are allowing to give the assessment to tourism potential of north eastern slope of Greater Caucasus e.g. identifying opportunities of perspective use of various territories for feature development of recreational tourism.

The results of studies are going to provide an opportunity for developing the maps of attractiveness of landscape on conducting zoning for tourism activity. Within the above mentioned research the application of specialized programs which are releasing us from hard, more connected works is giving an opportunity to develop complex morphometric maps of various complexity of space scale and content.

**С. А. Тарихазер**

География институты ӘҰҒА, Баку, Әзірбайжан

**СОЛТУСТИК-ШЫҒЫС ДІНІНІҢ МОРФОМЕТРИКАЛЫҚ ТАЛДАУ  
ТУРИЗМ ПОТЕНТАЛДЫҚ МАҚСАТЫ ҮШІН ҰЛЫ КАУКАЗДЫҢ АЯСЫ  
(ГАЗ технологиясын қолдану)**

**С. А. Тарихазер**

Институт Географии НАНА, Баку, Азербайджан

**МОРФОМЕТРИЧЕСКИЙ АНАЛИЗ РЕЛЬЕФА СЕВЕРОВОСТОЧНОГО  
СКЛОНА БОЛЬШОГО КАВКАЗА С ЦЕЛЮ ТУРИСТИЧЕСКОГО ПОТЕНЦИАЛА  
(с использованием ГИС-технологий)**

**Аннотация.** Разработка концепции, а вслед за этим и Государственной программы реорганизации и развития туризма в Азербайджане послужили толчком к созданию региональных программ развития туризма. С точки зрения развития туризма северо-восточный склон Большого Кавказа известен своим выгодным географическим положением на берегу Каспийского моря и туристической привлекательностью (горнолыжный спорт, альпинизм, экологические тропы и др.). Учитывая то, что до сегодняшнего дня научно-теоретическая и методологическая основа применения ГИС-технологий в туристической геоморфологии разработана недостаточно, в статье было проведено морфометрическое исследование северо-восточного склона Большого Кавказа в целях развития туризма. Морфометрический анализ исследуемой территории нами проведен с помощью цифровой модели рельефа (ЦМР) с использованием пакета ArcGIS. Исходными данными явились результаты радиолокационной съемки Shuttle radar topographic mission (SRTM), рассчитанной для создания высокоточной сети глобальной ЦМР. Ее среднеквадратическая погрешность оценивается по высоте примерно 16 м, а четкость положения узлов трехсекундной сетки составляет примерно 20 м, при том что в условиях горного рельефа данные показатели становятся больше. Снимок SRTM с разрешением примерно 60 м полезен для реализации морфометрического анализа и создания надлежащих карт в ГИС. Редактирование снимка, связанное с идентификацией и устранением незначительных погрешностей, выполнено с помощью средств пакета ArcGIS и его модуля Spatial Analyst. Карта углов наклона земной поверхности (крутизны склонов) нами составлена с использованием функции Special Analyst и ее

опции Surface analysis. При создании карты вертикального расчленения поверхности изолинии проведены через 100 м. Применяя выбранную градацию 0-20 м, 20-50 м, 50-100 м... 1300-1400 м, 1400 м и более, проведен анализ карты и выявлено, что значения глубины расчленения меняются в широких пределах от 0 до 1900 м. Можно заключить, что максимальные показатели вертикальной расчлененности соответствуют гипсометрически самым высоким территориям. На основе анализа морфометрических карт северо-восточного склона Большого Кавказа выявлено, что глубина расчленения наблюдается в пределах высот от -28 м до 4466 м, т.е. с увеличением абсолютной высоты, увеличивается и глубина расчленения.

Был проведен и сопоставительный анализ карты осредненных уклонов поверхности, где изолинии проведены через 5°. Из карты осредненных уклонов поверхности видно, что количественные показатели осредненных уклонов поверхности меняются в пределах от 0°-1° (в пределах Самур-Девичинской низменности) до 42°-43° (в высокогорной полосе Главного Водораздельного хребта).

На карте горизонтального расчленения поверхности изолинии проведены через 0,5 км/км<sup>2</sup>, где количественные показатели меняются от 0,1 до 4,0 км/км<sup>2</sup>. Ясно выраженного определенного простираения изолинии не имеют, однако доминирует поперечное направление, т.е. густота расчленения подчинена поперечному морфологическому расчленению территории. Максимальное расчленение 3-4,5 км/км<sup>2</sup> встречается в высокогорной приводораздельной зоне северо-восточного склона Большого Кавказа. Направление изолиний совпадает с направлением главных долин рек. Максимальные значения приурочены к среднегорьям и местами конусам выноса речных долин – 4,5 км/км<sup>2</sup> и более. Минимальные величины горизонтального расчленения свойственны для Самур-Девичинской низменности – 0-0,5 км/км<sup>2</sup>.

Для установления общего фона раздробленности современного рельефа разработана и принята 5-ти балльная шкала оценки морфометрической напряженности, куда включены степень горизонтальной и вертикальной расчлененности территории, уклон склонов и др. Полученные результаты можно использовать для создания инвестиционных проектов по развитию туризма на северо-восточном склоне Большого Кавказа.

В процессе освоения территории северо-восточного склона в целях развития туризма немаловажное значение имеет и проблема изучения, оценки и прогнозирования формирования современных опасных природно-разрушительных процессов. Геодинамически активное, дифференцированное развитие набора эндогенно и экзогенно обусловленных процессов рельефообразования неизменно меняет морфологический (морфометрический) вид рельефа, что очень важно учитывать при освоении крайне неустойчивых горных геосистем в целях рекреации. Наряду с этим огромную опасность образуют неожиданно зарождающиеся и активно проявляющиеся угрожающие или катастрофические эндодинамические и экзодинамические процессы. В статье кратко отражены закономерности проявления современных опасных экзодинамических процессов в разных экогеоморфологических ареалах северо-восточного склона Большого Кавказа. Анализ современных опасных рельефообразующих процессов исследуемой территории, горные системы которого в настоящее время интенсивно осваиваются с целью развития горного, а именно зимнего туризма и др., дает возможность сделать вывод, что в данном регионе Азербайджана самыми опасными процессами являются землетрясения, обвалы, оползни, сели, речная и плоскостная эрозия и др. Все эти процессы формируют общую экодинамическую напряженность. Для целей снижения опасности жизнедеятельности людей, туристическим объектам и др. необходимо выполнять предварительную крупномасштабную экспертную оценку экогеоморфологической обстановки в пределах выделенных экогеоморфологических районах до начала освоения в целях рекреационно-туристического освоения.

**Ключевые слова:** туризм, морфометрический анализ, морфометрическая напряженность, экзогенные процессы, экогеоморфологический район, опасность, ГИС-технологии

#### **Information about author:**

Tarikhazer Stara Abulfas gyzi, candidate of geographical sciences, associate professor, leading research worker of Institute of Geography named by acad. H.A. Aliyev of ANAS, Baku, Azerbaijan; kerimov17@gmail.com; <https://orcid.org/0000-0001-5870-1721>

## REFERENCES

- [1] Valeyev A.G., Akiyanova F.Zh, Abitbayeva A.D., Khalykov Ye.Ye., Togys M.M. Development of abrasion shores of Alakol lake according to the field research materials // *News of the National Academy of sciences of the Republic of Kazakhstan series of geology and technical sciences*. Vol. 1, N 433 (2019). P. 195–205. <https://doi.org/10.32014/2019.2518-170X.24> (in Eng.).
- [2] Dumit J.A. Using satellite imagery to build morphometric maps of relief (by data of the Kuban river basin) // *Actual issues of ecology and nature conservation of ecosystems of the southern regions of Russia and adjacent territories (Materials of the XX interregional scientific-practical conference)*. Krasnodar: Publishing House of KubSU, 2007. P. 91-92 (in Russ.).
- [3] Li Z., Zhu Q., Gold C. *Digital Terrain Modeling: Principles and Methodology*. CRC Press, 2004. 323 p. (in Eng.).
- [4] Sanchez P. Using ArcScan for ArcGIS. *Red-lands : ESRI*, 2003. 140 p. 119. (in Eng.).
- [5] McCoy J. *Geoprocessing in ArcGIS*. Redlands : ESRI, 2004. 363 p. (in Eng.).
- [6] Shary P.A., Sharaya L.S., Mitusov A.V. Fundamental quantitative methods of land surface analysis // *Geoderma*. 2002, 107 (1-2). P. 1-32. DOI: [10.1016/S0016-7061\(01\)00136-7](https://doi.org/10.1016/S0016-7061(01)00136-7) (in Eng.)
- [7] Alizade E.K., Tarikhazer S.A. Ecogeomorphological danger and hazards at Major Caucasus (in limits of Azerbaijan). Moskva: "MaksPrecc", 2015. 207 p. (in Russ.)
- [8] Ismaylova L.A., Guliyeva S.Y. Morphometric analysis in gis based of relief parameters mudflow basins // *News of the National Academy of sciences of the Republic of Kazakhstan series of geology and technical sciences*. Vol. 4, N 436 (2019). P. 128–136. <https://doi.org/10.32014/2019.2518-170X.106> (in Eng.).
- [9] Antiptseva J.O., Dumit Z.A. GIS-based morphometric analysis for the assessment of the recreational potential of Lagonak highland. *Geomorfologiya*, 2009. N 1. P. 45-50. <https://doi.org/10.15356/0435-4281-2009-1-45-50> (in Rus.)
- [10] Alizade E.K., Tarikhazer S.A. Exomorphodynamic of the mountains relief and its estimation (on the example of the north-eastern slope of the Major Caucasus). Baku: «Viktoriya», 2010. 236 p. (in Russ.).
- [11] Guliyeva S.Yu., Kuchinskaya I.Ya., Tarikhazer S.A., Karimova E.J. Natural and anthropogenic factors in hazard assessment of the alpine-himalayan montane ecosystems (an the example of the Azerbaijan Caucasus) // *Comptes rendus de l'Academie bulgare des Sciences Contents*. 2019. Vol. 72, Issue № 9. P. 1227-1233 DOI:10.7546/CRABS.2019.09.10 (in Eng.).
- [12] Tarikhazer S.A. Complex morphometric analysis of the Greater Caucasian territory based on GIS // *Proceedings of the Azerbaijan Geographical Society geography and natural resources*. Baku, 2018. N 2 (8). P. 17-29 (in Russ.).

NEWS

OF THE NATIONAL ACADEMY OF SCIENCES OF THE REPUBLIC OF KAZAKHSTAN

SERIES OF GEOLOGY AND TECHNICAL SCIENCES

ISSN 2224-5278

Volume 2, Number 440 (2020), 178 – 186

<https://doi.org/10.32014/2020.2518-170X.46>

UDC 622.23.05

**D. T. Khojibergenov<sup>1</sup>, B. K. Uralov<sup>1</sup>, Ye. P. Voevodin<sup>1</sup>, A. Abdugarimov<sup>2</sup>, B. N. Absadykov<sup>3</sup>**

<sup>1</sup>M. Auezov South Kazakhstan State University, Shymkent, Kazakhstan;

<sup>2</sup>I. A. Karimov Tashkent State Technical University, Tashkent, Uzbekistan;

<sup>3</sup>A. B. Bekturov Institute of Chemical Sciences, Almaty, Kazakhstan.

E-mail: uralov-1973.2@mail.ru, mr.abdali@mail.ru, b\_absadykov@mail.ru

## FEATURES OF DRILLING PROCESS KINEMATICS

**Abstract.** The results of the work aimed at studying the kinematics of the drilling process to determine the drilling pattern are presented. The analysis of the principles of operation of drilling tools has been conducted. It was determined that when working on the proposed drilling tools with the drilling force evenly distributed around the cutting edge, where the bottom hole reaction leads to a pair of forces that determine the amount of torque on the drilling tool. It has been defined that the cutting tooth of a drilling tool processes the slaughtering along the trajectory of the Bernoulli lemniscate, and all teeth, in particular the cutting edges of the drilling tool, are simultaneously involved in the destruction of the rock. Based on the studies conducted, the constructive scheme of the drilling tool was adjusted to determine the geometrical parameters of the cutting edge. The application of the proposed design scheme should allow increasing the mechanical drilling rate and reducing the values of arising drilling forces.

**Key words:** drilling, drilling tool, destruction, impact, rock, durability, scheme, force, kinematics, cutting-splitting, rotational drilling, rotational frequencies.

**Introduction.** In existing drilling technologies, various drilling methods are used with appropriate drilling tools [1-4]. The drilling technology is improving and the geometry of the drilling tool is optimizing.

However, in widely used technologies, the drilling pattern is based on the mechanism of rock destruction, where the teeth of drilling tools under the impact of strong blows scrape the rock. To increase the durability of drilling tools, expensive solid alloys and diamonds [5-10] are increasingly used. Used drilling patterns do not allow full use of these materials resource strength as they are fragile and do not tolerate impact loads.

To solve this problem, a group of scientists on the project “AP0513118 Creating drilling tools for drilling wells in the extraction of solid, liquid and gaseous minerals (contract No. 164 of 03/15/2018)” are investigating a new drilling pattern [11,12].

**The relevance of research.** The proposed drilling pattern and the correspondingly developed geometry of the drilling tool are related to rotary drilling technologies. The geometry of the drilling tool is not complicated by manufacturability. Prototypes were made in six coordinate machines, but in mass production the teeth can be made in other cheaper ways. The essence of the drilling scheme used is that the cutting tooth has continuous contact with the drilled surface, excluding vibration during the drilling process. The drilling pattern is based on cutting the soil. Changing the geometry of the drilling tool, it appears through the kinematics of the process to change the direction and values of the drilling force. With the proper formation of the drilling pattern, it is possible to achieve the appearance of negative drilling forces that will not repel but rather draw in the drilling tool in the direction of drilling.

**Objective.** Studies of drilling kinematics by definition drilling pattern.

**Material and research results.** According to the principle of interaction on the rock we consider the drilling pattern belonging to the cutting-cleaving groups [13]. It can be seen from the diagram (figure 1) that the element of the chisel’s armament moving at a speed of  $V_f$  and the effects of  $P_x$ ,  $P_z$  forces to a depth of  $\delta$  cuts off (cleaves) the rock.

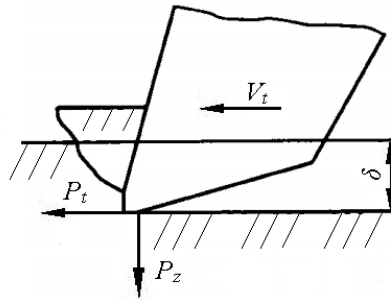

Figure 1 – Diagram of the impact of the rock-cutting tools armament elements on the rock when drilling

The dynamic process of destruction is determined by the equations of the kinetic energy  $T_k$  of the tool and the potential energy  $U$ . For this interaction pattern the condition  $P_z = 0$  (resistance of the rock to the introduction of a chisel) and indentation are considered as the main effect of the elements of the rock-breaking tools on the rock considered by researchers [13].

Other researchers believe [14] that during rotary drilling the destruction of rock at the bottom of a well occur due to the movement of a tool having the shape of a cutter along a helical line (figure 2). Such a movement is the result of a combination of rotational and translational movements. Rotational motion of the tool at the bottom of the hole is carried out by applying significant torque and large axial forces to the drilling tool a. There are no impact loads.

From the diagram it can be seen that from the side of the machine a pair of forces acts on the feather of the drill cutter (figure 2):  $P_y$  is the axial force and  $P_z$  is the cutting force [14]. Together they act on the mass destructible as the resultant force  $P$ . In turn, from the side of the rock the force is affected by the force  $P_y$  which characterizes the resistance of the rock to the introduction of the tool and  $P_z$  which characterizes the resistance of the rock to cutting [14]. As the result is force acting on the side of the rock mass on the tool  $R$ . When stresses are reached in the rock to be destroyed at a critical level, a cleavage will occur in the front face of the cutting tool. Then the tool will turn at a certain angle around its axis and stretch against the newly formed ledge and the process will repeat [14].

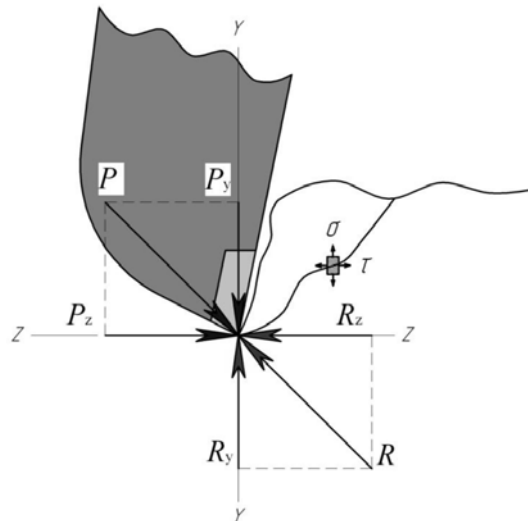

Figure 2 – Diagram of the operating forces at rotary drilling.  $P_y$  - axial force;  $P_z$  - cutting effort;  $P$  is the resultant force of the tool;  $R_y$  is rock resistance to penetration;  $R_z$  - rock cutting resistance;  $R$  is the resulting rock resistance;  $\sigma$ ,  $\tau$  - ultimate stress fracture

In the literature there are many materials on the research and application of drilling tools, but they are presented for specific cases, processing methods and geometry of drilling tools [15-21].

To study the kinematics of the drilling process, drilling tools were made of structural steel (figure 3). Experiments on drilling processes were carried out in soft and mixed soils since we needed to determine the kinematics without side effects.



Figure 3 – Drill tool with cutting teeth of 40X structural steel. 1 - body of the drilling tool; 2 - tip equipped with carbide plates of BK8 round shape; 3,4,5,6 - cutting teeth of the boring tool

The drilling process occurs due to the rotational  $\omega$  as well as the progressive action  $S$  of the drilling tool (figure 4):  $S=S_s+h_{tr}$ , where  $S_s$  is the stroke of the drilling tool;  $h_{tr}$  is a value of the stroke height of one tooth with one turn of the drilling tool

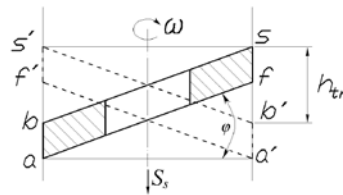

Picture 4 – Chart of moving of tooth of boring instrument

A tip 2 with round plates of hard alloy was designed for plunging into the ground. At the beginning of the process, cutting into the ground the tip equipped with round-shaped carbide plates from VK8 expands the hole to the diameter of the tooth 3 when bumping into a soil. Similarly, the 4, 5, 6 teeth will alternately bump into the soil. The values of the tooth inclination angle -  $\varphi$  was calculated to ensure a pure shear when cutting the soil. The distances between the teeth were selected in to ensure a continuous process of cutting the soil that is where the cutting of the soil ends with the first tooth the next one has time to bump into.

The conducted field tests showed that the process of bumping in and drilling occurs uniformly without jerks and jumps (figure 5).



Figure 5 – Drilling process at low speeds of the drilling tool

The cut soil volume of the initial drill hole did not have time to be removed from the drilling zone. In with connection, the holes were enlarged to the necessary appropriate dimensions in accordance with the geometrical parameters of the drilling tool.

The trajectory describing the edges of the cutting teeth  $a, b, s, f$  (figure 6, a) was investigated. When visually observed at small values of the drilling tool rotation, the points  $a, b, s, f$  during one turn describe the Cassini oval and occupy the position  $a', b', s', f'$  (figure 6, b) [22]. The kinematics of the drilling tool allows the cutting edge to move the bottom cut to the side in the direction of the drilling speed  $V_t$  tangentially to the cutting edge at that the first half of the tooth cutting edge is  $a, a_1, a_2, a_3, a_4$  and the second half of the tooth cutting edge  $a_4, a_5, a_6, a_7, a$  will form a resultant pair of forces. With an increase in the frequency of rotation of the drilling tool  $\omega$  the drilling force will probably decrease. The reason for this is the reduced volume of the cut soil layer.

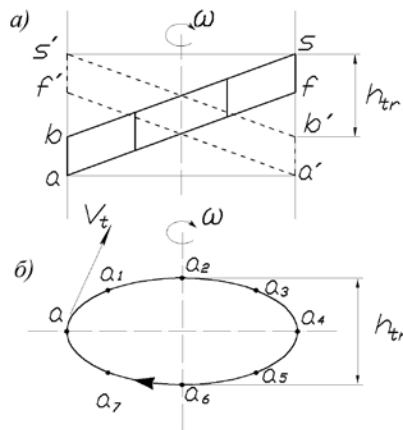

Figure 6 – Diagram for determining the trajectory of a cutting tooth of drilling tool at low turns

With an increase in the frequency of rotation of the boring tool  $\omega$  the trajectory of visual observation takes a different form (figure 7). It is assumed (figure 8) that in large values of the drilling tool rotation the points  $a, b, s, f$  during the half-turn describe the trajectory of the lemniscate and occupy the position  $a', b', s', f'$  (figure 8, b). The explanation for this is that in the particular case of the Cassini oval at a certain focal length is the trajectory of the Bernoulli lemniscate [23]. For large values of the rotational speed of the drilling tool, a part of the cutting edge of the tooth will act from below upwards  $a, a_1, a_2, a_5, a_4$  and will make a half turn moving the trajectory of the sinusoid when the second part of the cutting edge of a tooth is  $a_4, a_3, a_6, a_7, a, a$  will also move the trajectory of the sinusoid and close the lemniscate circle (figure 8, b). Divided into four parts in kinematics, cutting edge 1 part:  $a, a_1, a_2$ ; Part 2:  $a_2, a_5, a_4$ ; Part 3:  $a_4, a_3, a_6$ ; Part 4:  $a_6, a_7, a$  should significantly reduce the drilling force.



Figure 7 – Drilling process at high speeds of the drilling tool

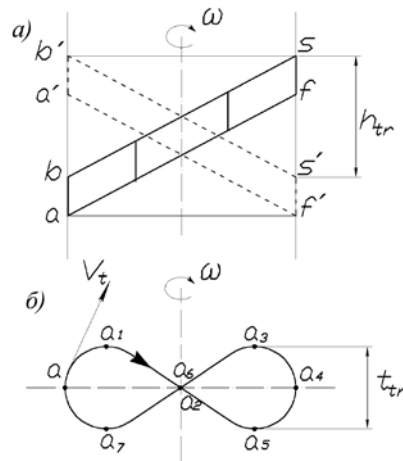

Figure 8 – Diagram for determining the trajectory of the cutting tooth of a drilling tool at high speeds

**Discussion of the drilling process with the use of the proposed drilling tool.** As a result of the field test data analysis the following recommendations were made to clarify:

Among drilling tools, screw or spiral drills [24-27] differ in cutting capacity and maneuverability. But the design of these drilling tools creates an accumulation of cut soil on the surface of the cutting blades or spirals. At high penetration rates, a process of jamming a drilling tool is created since the drilling fluid does not have time to raise the cut soil upwards.

In the proposed design, the drilling tool cuts the soil in portions, raises it upwards facilitating the removal of the cut soil from the drilling zone. The more turns of the drilling tool, the less the volume of the soil is cut off which increases the penetration of the drilling process.

Having studied the kinematics in the drilling tools made of structural steel which has convinced of the correctness of the drilling tool work it becomes possible to switch to the drilling of harder rocks. At the same time, as a cutting tooth for mixed soils we choose high-speed steel and carbide hard alloys for hard rocks.

Such studies will be sent to study the geometry of the cutting tooth, clarify the values of the working angles of the drilling tool, the front angle  $\gamma$ , the rear angle  $\alpha$ , the wedge angle  $\beta$ , and the angle of inclination of the cutting tooth  $\omega$ .

**Conclusions.** At this stage of research, summarizing the results, we draw the following conclusions:

1. It has been established that the proposed drilling tool and drilling pattern refers to the method of rotary drilling (figures 5,7).

2. It is determined that the drilling process is carried out by cutting and smoothly displacing the soil with the front surface of the cutting edge of the tooth of the drilling tool.

3. According to the proposed kinematics of the drilling pattern, the continuity of the trajectory of the cutting edge of the drill tool is provided (figure 8).

4. It has been established that the proposed kinematics of the drilling pattern significantly reduces the deviations of rotation from the axis of the drilling tool (figure 8).

5. It is assumed that the continuity of the contact of the cutting edges and the simultaneous participation of the teeth in the drilling process should reduce the drilling forces, as well as significantly reduce the vibration.

6. It is recommended to use the proposed technology of drilling and drilling tool teeth, which are made of high-speed steels in drilling wells for soft and mixed rocks. In this case, according to the proposed drilling scheme, the drilling tool is connected to standard drill pipes with transition sleeves.

Manufactured drilling tools for determining the kinematics of the drilling process have successfully passed field tests, and on the basis of the results obtained, it becomes possible to pass research by drilling for hard rocks.

**Д. Т. Ходжибергенов<sup>1</sup>, Б. К. Уралов<sup>1</sup>, Е. П. Воеводин<sup>1</sup>, А. Абдукаримов<sup>2</sup>, Б. Н. Абсадыков<sup>3</sup>**

<sup>1</sup>М. Өуезов атындағы Оңтүстік Қазақстан мемлекеттік университеті, Шымкент, Қазақстан;

<sup>2</sup>М. Улугбек атындағы Өзбекстан Ұлттық университеті, Ташкент, Өзбекстан;

<sup>3</sup>Ө. Б. Бектұров атындағы Химия ғылымдары институты, Алматы, Қазақстан

## **БҰРҒЫЛАУ ПРОЦЕСІ КИНЕМАТИКАСЫНЫҢ ЕРЕКШЕЛІКТЕРІ**

**Аннотация.** Жұмыста бұрғылау схемасын анықтау бойынша бұрғылау процесінің кинематикасын зерттеуге бағытталған нәтижелер берілген. Бұрғылау құралдарының жұмыс принциптеріне талдау жүргізілген. Жүргізілген зерттеулер негізінде кесу жиегінің геометриялық параметрлерін анықтау үшін бұрғылау құралының конструктивтік схемасы түзетілген. Ұсынылған конструктивтік схеманы қолдану бұрғылаудың механикалық жылдамдығын арттыруға және ұңғымаларды бұрғылаудың пайда болатын күштерінің мәнін төмендетуге мүмкіндік береді.

Қазіргі бұрғылау технологияларында тиісті бұрғылау құралдарымен бұрғылаудың әртүрлі әдістері қолданылады. Бұрғылау технологиясы жетілдірілуде, бұрғылау құралының геометриясы оңтайландырылуда. Алайда, кең қолданылатын технологияларда бұрғылау схемасы тау жыныстарының қирау механизміне негізделеді, онда бұрғылау құралдары тістерінің қатты соққыларының әсерінен тау жыныстарын ұсқынсыз қырады. Бұрғылау құралдарының беріктігін арттыру үшін қымбат тұратын қатты қорытпалар және алмаздар қолданылады. Бұрғылаудың қолданылатын схемалары осы материалдардың беріктілік ресурстарын толық пайдалануға мүмкіндік бермейді, өйткені олар өте нәзік болып келеді және соққы жүктемесін шығармайды.

Ұсынылған бұрғылау схемасы және бұрғылау құралының әзірленген геометриясы айналмалы бұрғылау технологияларына жатады. Бұрғылау құралының геометриясы дайындау технологиясы бойынша аса күрделі емес. Тәжірибелі үлгілер алты координаттық станокта жасалған, бірақ тістің сериялық өндірісінде басқа да неғұрлым арзан тәсілдермен дайындауға да болады. Қолданылатын бұрғылау схемасының мәні - кескіш тістің, бұрғылау бетімен үздіксіз байланыс жасай отырып, бұрғылау процесінде дірілді болдырмайды. Бұрғылау схемасы бұрғылау құралының геометриясын өзгерте отырып, топырақты кескілеуге негізделген, үрдістің кинематикасы арқылы бұрғылау күшінің бағыты мен мәнін өзгерту мүмкіндігі пайда болады. Бұрғылау сызбасын дұрыс қалыптастырған кезде оларды итермейтін бұрғылаудың теріс күштерінің пайда болуына қол жеткізуге болады, ал керісінше бұрғылау бағыты бойынша бұрғылау құралын созатын болады.

Басқа зерттеушілер айналмалы бұрғылау кезінде ұңғыманың кенжарында жыныстың бұзылуы кескіш формасы бар құралдың бұрамалы сызықпен қозғалуының арқасында болады деп есептейді. Мұндай қозғалыс айналмалы және үдемелі қозғалыстардың нәтижесі болып табылады. Теспенің кенжарында құралдың айналмалы-үдемелі қозғалысы бұрғылау құралына айтарлықтай айналдыру сәті мен үлкен осьтік күш жұмсау есебінен жүзеге асырылады. Бұл ретте соққы жүктемелері орын алмайды.

Әдебиетте бұрғылау құралдарын зерттеу және қолдану бойынша көптеген материалдар бар, алайда олар нақты жағдайлар мен өңдеу тәсілдері үшін ұсынылған. Бұрғылау процесінің кинематикасын зерттеу үшін конструкциялық болаттан жасалған бұрғылау құралдары дайындалды. Өрістік сынақтар BZC 600A өздігінен жүретін бұрғылау агрегатында жүзеге асырылды. Бұрғылау құралы Ø 190,5 мм өтпелі төлкесі бар бұрғылау құбырларына қосылды. Бұрғылау процестері бойынша эксперименттер жұмсақ және аралас топырақтарда жүргізілді, себебі жанама әсерсіз кинематиканы анықтау қажет болған. Өткізілген өрістік сынақтар кесу және бұрғылау процесі бірқалыпты, жұлқыпсыз және өзгеріссіз жүретінін көрсетті. Бұрғылау станогының бастапқы тесігі бұрғылау аймағынан кесілген топырақ көлемін шығаруға үлгермеді. Осыған байланысты тесігі бұрғылау құралының геометриялық параметрлеріне сәйкес қажет тиісті өлшемдерге дейін ұлғайған.

Өріс сынақтарының алынған деректерін талдау нәтижесінде нақтылау үшін келесідей ұсынымдар жүйеленген: Бұрғылау құралдарының арасында ойып алуы және өтімділігі жағынан шнекті немесе спираль тәрізді бұрғылары ерекшеленеді, бірақ осы бұрғылау құралдарының конструкциясы кесетін қалақтардың немесе спиральдың бетінде кесілген топырақты жинайды. Үңгілеу жылдамдығы жоғары болған кезде бұрғылау құралын сындыру процесі құрылады, өйткені бұрғылау ерітіндісі кесілетін топырақты жоғары көтере алмайды. Ұсынылып отырған конструкцияда бұрғылау құралы топырақты порциялармен кесіп, бұрғылау аймағынан қиылған топырақтың ағуын жеңілдетіп, оны жоғары көтереді. Бұрғылау құралының айналымы неғұрлым көп болған сайын, бұрғылау процесінің өтуін арттыратын топырақ көлемі соғұрлым аз

кесіледі.

Конструкциялық болаттан жасалған бұрғылау құралдарының кинематикасын зерттей отырып, бұрғылау құралының дұрыс жұмыс істеуіне көз жеткізген қатты тау жыныстарын бұрғылау мүмкіндігі пайда болады. Бұл ретте кескіш тістің материалы ретінде аралас топырақтар үшін тез кесетін болатты, ал қатты жыныстар үшін екі карбидті қатты қорытпалары таңдалған.

**Түйін сөздер:** бұрғылау, бұрғылау құралы, қирау, сокқы, тау жынысы, беріктік, схема, күш, кинематика, кесу-бөлу, айналмалы бұрғылау, айналу жылдамдығы.

**Д. Т. Ходжибергенов<sup>1</sup>, Б. К. Уралов<sup>1</sup>, Е. П. Воеводин<sup>1</sup>, А. Абдукаримов<sup>2</sup>, Б. Н. Абсадықов<sup>3</sup>**

<sup>1</sup>Южно-Казахстанский государственный университет им. М. Ауэзова, Шымкент, Казахстан;

<sup>2</sup>Ташкентский государственный технический университет им. И. А. Каримова, Ташкент, Узбекистан;

<sup>3</sup>Институт химических наук им. А.Б. Бектурова, Алматы, Казахстан

### **ОСОБЕННОСТИ КИНЕМАТИКИ ПРОЦЕССА БУРЕНИЯ**

**Аннотация.** В работе представлены результаты, направленные на исследования кинематики бурильного процесса по определению схемы бурения. Проведен анализ принципов работы бурильных инструментов. На основе проведенных исследований была скорректирована конструктивная схема бурильного инструмента для определения геометрических параметров режущей кромки. Применение предложенной конструктивной схемы должна позволит повысить механическую скорость бурения и снизить значения возникающих сил бурения скважин.

В существующих технологиях бурения используются различные методы бурения с соответствующими бурильными инструментами. Совершенствуются технологии бурения, оптимизируется геометрия бурильного инструмента. Однако в широко применяемых технологиях схема бурения основывается на механизме разрушения пород, где зубы бурильных инструментов под воздействием сильных ударов скоблят горную породу. Для повышения стойкости бурильных инструментов все больше используются дорогостоящие твердые сплавы, алмазы. Применяемые схемы бурения не позволяют полностью использовать прочностные ресурсы этих материалов, так как они являются хрупкими и не выносят ударные нагрузки.

Предлагаемая схема бурения и соответственно разработанная геометрия бурильного инструмента относится к технологиям вращательного бурения. Геометрия бурильного инструмента несложная по технологичности изготовления. Опытные образцы изготавливались на шести координатных станках, но в серийном производстве зубья можно изготавливать другими, более дешевыми способами. Суть применяемой схемы бурения в том, что режущий зуб, имея непрерывный контакт с буримой поверхностью, исключает вибрацию в процессе бурения. Схема бурения основана на срезании грунта, изменяя геометрию бурильного инструмента, появляется возможность через кинематику процесса изменить направления и значения силы бурения. При правильном формировании схемы бурения можно добиться появления отрицательных сил бурения, которые не будут отталкивать, а, наоборот, втягивать бурильный инструмент по направлению бурения.

Другие исследователи считают, что при вращательном бурении разрушение породы на забое скважины происходит благодаря движению инструмента, имеющего форму резца, по винтовой линии. Такое движение является результатом сочетания вращательного и поступательного движений. Вращательно-поступательное движение инструмента на забое шпура осуществляется за счет приложения к буровому инструменту значительного крутящего момента и больших осевых усилий. Ударные нагрузки при этом отсутствуют.

В литературе имеется множество материалов по исследованию и применению бурильных инструментов, однако они представлены для конкретных случаев и способов обработки. Для исследования кинематики процесса бурения изготавливались бурильные инструменты из конструкционной стали. Полевые испытания осуществлялись на самоходном буровом агрегате ВЗС 600А. Бурильный инструмент соединялся к бурильным трубам с переходной втулкой Ø 190,5 мм. Эксперименты по бурильным процессам проводились в мягких и смешанных грунтах, так как нам необходимо было определить кинематику без побочных действий. Проведенные полевые испытания показали, что процесс врезания и бурения происходит

равномерно, без рывков и скачков. Первоначальное отверстие бурового станка не успевало вывести из зоны бурения срезанный объем грунта. В связи с чем отверстие увеличивалось до необходимых соответствующих размеров в соответствии с геометрическими параметрами бурильного инструмента. В результате анализа полученных данных полевых испытаний сформированы следующие рекомендации для уточнения: среди бурильных инструментов врезаемостью и проходимостью отличаются шнековые или спиральные буры, но конструкция этих бурильных инструментов создает накопление срезанного грунта на поверхности режущих лопастей или спирали. При больших скоростях проходки создается процесс заклинивания бурильного инструмента, так как буровой раствор не успеет поднять наверх срезаемый грунт. В предлагаемой конструкции бурильный инструмент, срезая грунт порциями, поднимает ее наверх, облегчая увод срезанного грунта из зоны бурения. Чем больше оборотов бурильного инструмента, тем меньше срезается объем грунта, который повышает проходку бурильного процесса. Изучив кинематику бурильных инструментов, изготовленных из конструкционной стали, убедившись в правильности работы бурильного инструмента, появляется возможность бурения более твердых пород. При этом в качестве материала режущего зуба выбираем для смешанных грунтов быстрорежущую сталь, а для твердых пород – двухкарбидные твердые сплавы.

**Ключевые слова:** бурение, буровой инструмент, разрушение, удар, порода, прочность, схема, сила, кинематика, резка-раскалывание, вращательное бурение, частоты вращения.

#### Information about authors:

[Khojibergenov Davlatbek Turganbekovich](https://orcid.org/0000-0003-0039-9931), Doctor of Technical Sciences, Director of Science and Production Department, M. Auezov South Kazakhstan State University, Shymkent city, Kazakhstan; had\_ji@mail.ru; <https://orcid.org/0000-0003-0039-9931>

Uralov Baidulla Kidirbayevich, Candidate of Technical Sciences, Associate Professor, M. Auezov South Kazakhstan State University, Shymkent city, Kazakhstan; uralov-1973.2@mail.ru; <https://orcid.org/0000-0001-5056-3336>

Absadykov Bakhyt Narikbayevich, Doctor of Technical Sciences, Deputy general Director, A. B. Bekturov Institute of Chemical Sciences, Almaty, Kazakhstan; b\_absadykov@mail.ru; <https://orcid.org/0000-0001-7829-0958>

Voevodin Yevgenii Petrovich, Senior lecturer, M. Auezov South Kazakhstan State University, Shymkent city, Kazakhstan; voevodin46@inbox.ru; <https://orcid.org/0000-0002-8863-3253>

Abdukarimov Abdaly, Candidate of Technical Sciences, Associate Professor, I. A. Karimov Tashkent State Technical University, Tashkent city, Uzbekistan; mr.abdali@mail.ru; <https://orcid.org/0000-0001-7635-4321>

#### REFERENCES

- [1] <https://www.rocktechnology.sandvik/globalassets/products/rock-tools>. Rotary drilling bits and drill string tools.
- [2] <https://link.springer.com/article/10.1007%2Fs12182-019-0318-6>. The rock breaking and ROP increase mechanisms for single-tooth torsional impact cutting using DEM.
- [3] <https://www.researchgate.net/publication/318147909>. Structural drilling using the high-frequency (sonic) rotary method.
- [4] <https://www.researchgate.net/publication/283427119>. Rotary - percussion drilling method – historical review and current possibilities of application.
- [5] [https://www.metotech.ru/art\\_tvsplyvy\\_2.htm](https://www.metotech.ru/art_tvsplyvy_2.htm). *Tverdyye splavy i ikh primeneniye dlya burovogo i gornogo oborudovaniya* [Hard alloys and their application for drilling and mining equipment]
- [6] <https://studref.com/608693/geografiya/>. *Burovyye instrumenty s reztsami iz tverdykh materialov s polikristallicheskimyalmazami* [Drilling tools with cutting edges made of hard materials with polycrystalline diamond]
- [7] <http://www.drillings.ru/izgzubdol>. *Tverdyye splavy dlya izgotovleniya zubkov dolot* [Hard alloys for making teeth bits].
- [8] <https://link.springer.com/article/10.3103%2FS0967091217010041>. Manufacture of drill bits from new diamond materials at high pressures and temperatures.
- [9] Scott D., Stockeydr D., and Digiovanni A., Engineered geometries for PDC cutters extends the life and performance of PDC drill bits, *Finer Points*, 2015. N 1. P. 19–20.
- [10] García-Marro F., Mestra A., Kanyanta V., Maweja K., Ozbayraktar S., and Llanes L., Contact damage and residual

strength in polycrystalline diamond (PCD), *Diamond Relat. Mater.*, 2016. Vol. 65. P. 131–136.

[11] Khojibergenov D.T., Yanyushkin A.S., Ibragimova Z.A., Khozhibergenova U.D., Sherov K.T., Absadykov B.N. Drilling tool with negative drilling force value // *News of the National Academy of Sciences of the Republic of Kazakhstan. Series of Geology and Technical Sciences*. 2019. N 1. P. 169–175. <https://doi.org/10.32014/2019.2518-170X.21>

[12] Khodzhibergenov D.T., Sherov K.T., Yesirkepov A. *Sposob bureniya i konstruktsiya kombinirovannogo bura sverlo-freza* [The method of drilling and the design of the combined drill-mill]. *Bulletin of engineering*. 2019. No. 5. – P. 58-60.

[13] Spivak A.I., Popov A.N., Akbulatov T.O. and others. *Tekhnologiya bureniya nefyanykh i gazovykh skvazhin* [Technology of drilling oil and gas wells]. M.: LLP “Nedra-Biznestzentr”, 2003. 509 p.

[14] Grinko D.A. *Metod rascheta i podderzhaniya ratsional'nykh rezhimnykh parametrov buril'noy mashiny mekhatronnogo klassa* [The method of calculating and maintaining rational operational parameters of the boring machine of mechatronic class]. *Dis. Cand. Tech. Science, Novocherkassk*, 2015. 158 p.

[15] <https://doi.org/10.4028/www.scientific.net/KEM.250.110>. Li X., Zhang Q., Li J., Zhao J. A numerical study of rock scratch tests using the particle-based numerical manifold method. *Tunn Undergr Space Technol.* 2018; 78: 106–14. <https://doi.org/10.1016/j.tust.2018.04.029>.

[16] Li Y., Peng J., Zhang F., Qiu Z. Cracking behavior and mechanism of sandstone containing a pre-cut hole under combined static and dynamic loading. *Eng Geol.* 2016; 213: 64–73. <https://doi.org/10.1016/j.engge o.2016.08.006>.

[17] Sapińska-Śliwa A., Wiśniowski R., Korzec M., Gajdosz A., Śliwa T. Rotary-percussion drilling method—historical review and current possibilities of application. *AGH Drill.* 2015; 32 (2): 313–22. <https://doi.org/10.7494/drill.2015.32.2.313>.

[18] Yang G., Cai Z., Zhang X., Fu D. An experimental investigation on the damage of granite under uniaxial tension by using a digital image correlation method. *Opt Lasers Eng.* 2015; 73: 46–52. <https://doi.org/10.1016/j.optla seng.2015.04.004>.

[19] Zhang M.M. Study of rock breaking simulation of a PDC bit based on discrete element method. Master thesis. 2017. Southwest Petroleum University, China (in Chin.).

[20] Zhu X., Tang L., Tong H. Effects of high-frequency torsional impacts on rock drilling. *Rock Mech Rock Eng.* 2014; 47 (4): 1345–54. <https://doi.org/10.1007/s00603-013-0461-0>.

[21] Zhu X.H., Liu W.J. The rock breaking and ROP rising mechanism for single-tooth high-frequency torsional impact cutting. *Acta Petrolei Sinica.* 2017; 38 (5): 578–86. <https://doi.org/10.7623/syxb201705011> (in Chin.).

[22] <https://yandex.kz/search/?text=oval+Kassini>.

[23] [https://ru.wikipedia.org/wiki/Lemniskat\\_Bernulli](https://ru.wikipedia.org/wiki/Lemniskat_Bernulli) [Lemniscate Bernulli].

[24] <https://poleznayamodel.ru/model/11/111183.html>. *Shnekovyi bur dlya vrashchatel'nogo bureniya skvazhin* [Auger drill for rotary drilling]

[25] <https://byreniepro.ru/byr-instrumenty/shnekovoe-burenje.html>. *Osobennosti shnekovogo bureniya skvazhin* [Features of auger well drilling].

[26] <http://www.drillings.ru/insr-shnek>. *Burovoy instrument dlya shnekovogo bureniya* [Drilling tool for auger drilling].

[27] <https://www.britannica.com/technology/hand-tool/Drilling-and-boring-tools>. Drilling and boring tools.

**NEWS**

OF THE NATIONAL ACADEMY OF SCIENCES OF THE REPUBLIC OF KAZAKHSTAN

**SERIES OF GEOLOGY AND TECHNICAL SCIENCES**

ISSN 2224-5278

Volume 2, Number 440 (2020), 187 – 197

<https://doi.org/10.32014/2020.2518-170X.47>

UDC 625.855.52

MRNTI:

**B. M. Khroustalev<sup>1,4</sup>, T. Liu<sup>1,2,3</sup>, A. V. Busel<sup>1,5</sup>, Zh. Li<sup>1,3</sup>,  
U. A. Veranko<sup>1,4</sup>, V. V. Zankavich<sup>1</sup>, B. Shang<sup>2,3</sup>**<sup>1</sup>Henan Gaoyuan highway maintenance technology Co., Ltd  
(Henan center for outstanding overseas scientists), Xinxiang, China;<sup>2</sup>National engineering laboratory for highway maintenance equipment, Xinxiang, China;<sup>3</sup>Henan provincial key laboratory of highway detection and maintenance, Xinxiang, China;<sup>4</sup>Science and technology park of Belarusian national technical university "Polytechnic", Minsk, Belarus;<sup>5</sup>State enterprise "Belarusian road scientific and research institute «BeldorNII", Minsk, BelarusE-mail: post@park.bntu.by, verenko.vladimir@gmail.com, liutingguo@chngaoyuan.com,  
bulex@tut.by, vitali.zankavich@chngaoyuan.com, lizhongyu@chngaoyuan.com, iver-sb@163.com**ESTIMATION AND METHODS OF PREDICTION  
FOR THE STRUCTURAL AND MECHANICAL PROPERTIES  
OF RAP-COMPOSITES**

**Abstract.** This article presents the study results of the processes of structure formation and analysis of the methodological evaluation features of strength and deformation properties of RAP-composites. New materials necessitate studying the peculiarities of their behavior in the temperature-time field in order to develop objective technical requirements for their physical and mechanical characteristics that allow them to provide the required values of strength and reliability.

The classical method of applying the temperature-time analogy is valid in the linear domain for the analysis of relaxation curves at low levels of deformation or creep curves at low stresses. This thesis does not allow this theory to be used for the analysis of strength properties and other characteristics associated with the process of destruction of the composite material. Concretes of composite structure containing thermodynamically incompatible binders have nonlinear viscoelasticity and are thermorheologically complex. For composite materials a reduction factor (the amount of displacement curves along the time or deformation speed axis) depends not only on temperature but also material properties, and stress state. This is due to the peculiarities of the structure of composite materials as a system with a complex set of elastic and viscous bonds, and therefore the reduction coefficient depends on the number of elastic bonds involved in the deformation process.

The research is based on the principles of temperature-structural analogy, allowing predicting the properties of composites on organo-hydraulic binders. This makes possible directionally to design a cold mix and to determine the way of reaching a required materials property for construction of different layers of pavement.

The proposed methodological principles of design are based on the determination of the optimal ratio of elastic and viscous bonds, considering the properties of RAP and the amount of cement. The use of this approach allows evaluating the potential maximum durability of composites, practicability of the introduction of various modifying components and the optimum content of the organic binder.

**Key words:** asphalt concrete regeneration, composite based on organo-hydraulic binder, cold RAP-mix, fatigue life, temperature-structural analogy, rheological properties, maximum structural strength

**Introduction.** Asphaltic cement composites of various composition and preparation technology are widely used in road construction practice. These asphalt cement composites are hereinafter referred to as the concretes based on organo-hydraulic binders (concretes on OHB). The concrete that is on OHB is an artificial construction material with a structure combining the properties of thermodynamically incompatible organic (bitumen, tars) and hydraulic (cement, gypsum, ash, and etc.) binders. It is particularly

important when old spent materials are reused in new construction. The reuse of pavement layer materials is an urgent issue in the road-building industry of most countries around the world. Recycling or reuse (regeneration) of materials of existing pavements during their renovation and repair is not a new concept; such projects with varying degrees of success have been implemented since the beginning of the 20th century [1-3].

The regenerated materials without mineral binder (cement) exhibit viscoelastic properties within a wide temperature-time range; plastic deformations and fatigue cracks are the main possible defects in pavements based on the materials stabilized in such a way; and vice versa, when the mineral binder content is increased, the elastic properties and increased shear resistance at high temperatures are exhibited but brittle properties which stimulate low-temperature cracking and reduction of cyclic durability may appear to a greater extent [4-6]. In this regard, increasing attention is being paid to improving the quality of composite materials obtained from the processing of existing road pavements and their reuse in the repair and construction of new pavements [7-9].

In most countries of the world, the required quality indicators of cold regenerated mixtures and concretes are similar and are focused primarily on the regulation of properties via implementation of a set of tests for [10-12]:

- shear resistance;
- crack resistance and fatigue;
- water resistance and frost resistance.

When determining the design parameters required for pavements design and prediction of composite material properties, the provisions of the Williams-Landel-Ferry theory are often used with plotting the main deformation curve and its subsequent shifting depending on the predicted level of load and temperature impact [13-15]. This makes it possible to assess the composites within a wide range of external impacts, as well as to evaluate their fatigue and fatigue life more effectively.

The difficulty of assessing the properties of composite materials on OHB is that they combine the properties of coagulation, condensation and crystallization structures. In such systems, the arrangement of the various bonds is not uniform in the material volume; the strength and deformability of structural aggregates and clusters are also very heterogeneous. With regard to deformation and destruction mechanics, the structure of such materials can be represented in the form of a phenomenological model with a complex set of elastic, viscous and plastic bonds alternating in series and in parallel [16]. This is due to the fact that the processes of influence of hydraulic binder at the levels of microstructure, mesostructure and macro-structure are not sufficiently studied taking into account the properties of the polygranular filler, that is RAP.

**Thesis statement.** Many years of experimental studies of composites on OHB and strength analysis of their unbroken and broken structures have confirmed the possibility of phase contacts when the thickness of organic binder films is within 1-5  $\mu\text{m}$ . However, taking into account the low strength of phase contacts in the presence of such films, they cannot be defined as the main structure-forming factors. In this case, the main structure-forming element is phase-to-phase transition layers of cluster type, the formation of which is influenced both by physical (crystal intergrowth, adsorption, destruction of bitumen associates, ion transfer, formation of double electronic layers) and chemical (formation of bonds of  $\text{Me}^+-\text{OOCR}$  type, hydrogen  $-\text{H}-\text{O}$ , and etc.) processes. The  $\text{Me}^+-\text{OOCR}$  bonds are formed by metal ions, their oxides and hydroxides arising from hydration of the mineral binder due to interaction with oxygen, hydroxyl and carboxyl groups of the organic binder. The hydroxyl groups of hydration products and hydroxyl, nitrogen and sulphur compounds of bitumen are involved in formation of hydrogen bonds [17,18].

Thus, at the interface between the phases of the mineral and organic binder, a certain transition layer with special properties is formed; it is formed by clusters of different sizes, including nanodomains with a different charge transfer between the system components. In these cluster domains, the interaction of atoms differs from the interaction of atoms in isolated domains of cement, bitumen, and water that significantly affects the entire complex of system properties. Therefore, the structure of composites based on cement and bituminous binders is presented by the cement aggregates hydrated to varying degrees and a number of phase-to-phase transition layers.

According to the presented structure formation scheme, the hydraulic binder's impact on the composite structure and properties manifests itself by the mechanism of an active, colmatage and reinforcing filler. Moreover, it refers to the macro- and microstructure. First of all, the cement is a

reinforcing filler forming secondary structures in a bituminous or asphalt concrete matrix. The secondary structures of the mineral binder can interact with each other via phase contact or transition layers having higher strength than the bituminous matrix. As a result, the space reinforcing network with a "hinged" connection in the nodes of varying degrees of mobility is formed. The mineral binder has a colmatage effect because its aggregates, unlike inert fillers, are a rather monolithic system after hydration processes.

The structure formation processes are even more difficult when concretes on OHB are prepared with the use of RAP as fillers. The main feature of intercontact interaction of such filler and organo-hydraulic binder is the fact that RAP is a polygranular material in which the most part of grains is covered with an aged organic binder (as a rule, with a bituminous binder). Consequently, the majority of strong phase contacts with the formation of continuous condensation-crystallization backbone is developed via the filler particles not coated with bitumen, as well as due to partial penetration of crystal whiskers into the bitumen films and during interaction of hydration products with active bitumen components on the surface of RAP-particles. As a result, the formed space condensation and crystallization structure determines the elastic properties of the composite.

As described above, the strength of the condensation and crystallization backbone in the composites on OHB is determined by a ratio of concentrations by volume of bituminous and cement phases. As the volume of the bitumen phase is increased, the strength of the condensation and crystallization structure is decreased. However, the bitumen in the composite material at the macro- and mesostructure level can be located on the RAP surface in the form of structured films and fill the space between the aggregate particles and the products of cement hydration that contributes to reducing the porosity and increasing the hydrophobic properties of the composite.

Based on the full complexity of processes occurring when the structure of composites is formed on the RAP and organo-hydraulic binder, there is an important issue to ensure and predict their mechanical-and-physical properties. This issue should be addressed at the composition design stage. Currently, the majority of methodologies to assess the properties of such composite materials, including the methodology of Standard JTG F41-2008 "Technical Specifications for Highway Asphalt Pavement Recycling" [19], do not allow to predict the efficiency of one or another technical solution of cold regeneration of road asphalt concrete pavements while taking into account the features of interaction during the formation of condensation-and crystallization and coagulation structures of RAP with a complex organo-hydraulic binder within a wide range of their initial properties.

**Novelty.** The main method of predicting the strength and deformation characteristics within a wide range of temperatures and load action time is the principle of temperature-time analogy (TTA), according to which the experimental curves obtained at different temperatures can be combined by parallel shifting along the axis of time  $t$  (or deformation rate) [20,21].

Figure 1 shows the general curve of the relaxation modulus of concrete on OHB prepared using RAP (30% in the filler composition) with addition of 3% of cement and 5% of bitumen emulsion. This curve is plotted by horizontally shifting (with the factor  $a_t$ ) the outgoing relaxation constraints  $E(t)$  along the axis.  $\lg t$

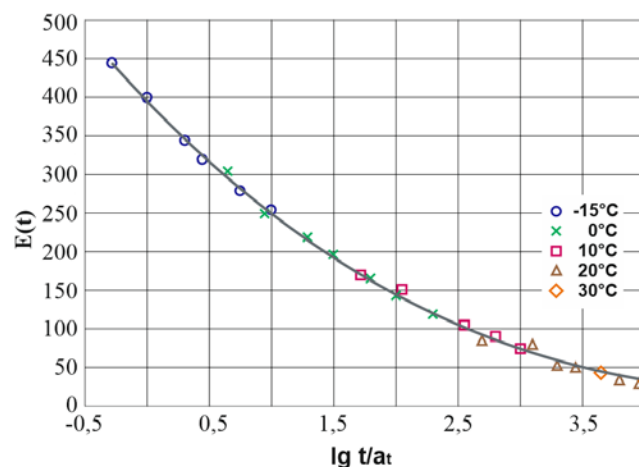

Figure 1 – A general curve of the relaxation modulus

In all cases, the temperature dependence of the shift factor  $\lg a_t$  from  $(T - T_0)$  is well represented by the power function:

$$\lg a_t = A \cdot (T - T_0)^m, \tag{1}$$

where  $T$  – test temperature, °C;  $T_0$  – reduction temperature, °C;  $A$  and  $m$  – constant parameters.

The examples of parameter values of dependence of this type on the material composition are given in table 1.

Table 1 – The value of constant parameters to determine the shift factor  $a_t$

Composition*	A, 10 <sup>2</sup>	m	$\lg a_t$ **
BE – 3%; P – 0%	3.5	1.30	1.72
BE – 5%; P – 0%	3.7	1.34	2.05
BE – 3%; P – 2%	4.1	1.21	1.54
BE – 3%; P – 4%	4.9	1.09	1.28
BE – 5%; P – 6%	5.2	1.02	1.10

\* The RAP content in the filler composition is 30%.  
 \*\* reduction to temperature 10°C (test temperature – 30°C).  
 BE – Bitumen emulsion.  
 P – Portland cement.

As can be seen from table 1, the shift factor is decreased as the weight fraction of the hydraulic binder is increased, indicating that the temperature and time sensitivity of the concretes on the organo-hydraulic binders are decreased if the condensation- crystal lattice is formed in their structure.

At the same time, the classical method of applying the temperature-time analogy is valid in the linear range for analyzing the relaxation curves at low strain levels or the creep curves at low stresses. This provision does not allow us to use it for the analysis of strength properties and other characteristics related to the process of composite material destruction.

The concretes with a composite structure containing the thermodynamically incompatible binders have nonlinear viscoelasticity and are complex in their thermo-rheological properties. A simple visual analysis shows that parallel transfer does not allow the strength-versus-strain rate curves to be aligned (figure 2). Therefore, the reduction factor (the value of shifting the curves along the axis of time or strain rate) depends not only on the temperature but also on the material properties and the degree of strain condition. The situation is even more complicated when RAP obtained from reprocessing of asphalt concrete pavements is used as a filler (part of the filler).

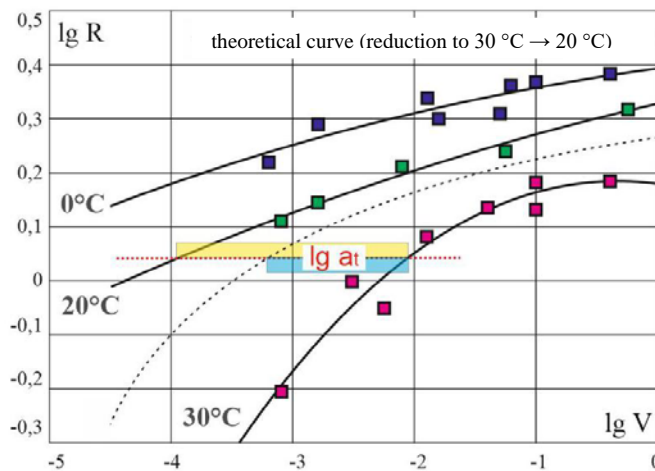

Figure 2 – Bending strength from deformation rate for the concrete based on organo-hydraulic binder

This is due to the features of the composite material structure as a system with a complex set of elastic  $n_r$  and viscous bonds  $n_v$  [16]; that's why the reduction factor  $\lg a_t$  depends mainly on the number of elastic bonds involved in the deformation process. It is valid since the temperature, tension, time changes cause a change in the course of relaxation processes on which the value  $n_r$  directly depends.

If  $n_r = 1$ , then the material properties are practically independent of temperature, stress, time, i.e. the material is "absolutely elastic" and the reduction factor is equal to 1 ( $\lg a_t = 0$ ). If  $n_r$  is decreased and tends to zero, then the material properties become close to viscous ones; the value  $\lg a_t$  can be determined by the Williams-Landel-Ferry equation (WLF) [20, 21]:

$$\lg a_t^{WLF} = -\frac{17,44 \cdot (T - T_q)}{51,6 + (T - T_q)}, \quad (2)$$

where  $T$  – current temperature, K;  $T_q$  – glass transition temperature, K.

Using the additivity concept, we obtain:

$$\lg a_t = (1 - n_r) \cdot \lg a_t^{WLF}. \quad (3)$$

The value  $n_r$  can be determined by the condition [16]:

$$n_r = \frac{E_t}{E_c} = \left( \frac{R_t}{R_c} \right)^{\frac{1}{m}}, \quad (4)$$

where  $E_t$  and  $R_t$  – relaxation modulus and material strength under specific conditions of loading;  $E_c$  and  $R_c$  – maximum values of modulus and strength within the entire range of temperatures and load action time;  $m$  – parameter that depends on the material type. For example, for asphalt cement compositions it ranges from 0.8 to 0.95.

Thus, the value  $a_t$  can be characterized not only by the viscous properties but also by the elastic properties of the composite material. Taking into account that the changes in the composition and structure of concretes on OHB, in the stress degree at the same temperature and time of its action leads primarily to change of the value  $n_r$ , it is possible to predict its rheological properties in case of a change in temperature or time of load action. From the point of view of rheological behavior, the change of  $n_r$  due to the structure variation is similar to its change due to variation of temperature or time of load action, taking into account the initial properties of composite material. This provision allows the concept of temperature-structural analogy (TSA) to be applied in a similar way to the concept of temperature-time analogy (TTA).

**Study methods and results.** Dependence (3) according to the WLF is valid if the glass transition temperature is taken as the reduction temperature. In the case of a random selection of the reduction temperature, it is necessary to adjust the value of WLF factors according to the procedure [21]. The experimental studies and calculations (Fig. 2) have shown that the theoretical curve obtained by the TTA method (dashed line) differs from the experimental curves.

The WLF equation (2) is valid if the glass transition temperature is taken as the reduction temperature. In case of random selection of the reduction temperature, it is necessary to adjust the value of WLF factors according to the procedure [20]. It is possible to use a simplified dependence obtained by shifting the WLF curve along the axes of temperature and reduction factor  $\lg a_t$ . In this case, the factor  $T_{pr}$  of reduction to random temperature is determined from the expression:

$$\lg a_t = \lg a_t^{WLF} - \lg a_t^{T_{pr}}, \quad (5)$$

The value  $\lg a_t^{T_{pr}}$  is calculated by (2) replacing the current temperature ( $T$ ) with the reduction temperature ( $T_{pr}$ ).

Table 2 shows the values of the factor of creep modulus reduction to the temperature of 0°C which is obtained experimentally (by combining the curves) and theoretically. The studies were carried out using the samples from RAP with addition of 3 % of cement and 5 % of bitumen emulsion at a temperature of 0°C and 20°C at two levels of strain. In case of theoretical determination, the value  $n_r$  was obtained by  $\lg a_t$  (2), then the value  $\lg a_t$  was obtained using (2) and (5). The temperature of structural glass transition ( $T_q$ ) was 12°C.

Table 2 – Values of the reduction coefficient for different methods of determination

Time of load action at 20°C, s	Number of elastic bonds according to (4) under strains, MPa		Logarithm of the factor of reduction $\lg a_t$ to temperature of 0°C under strains, MPa	
	0.2	0.4		
3.0	0.70	0.60	$\frac{-0.7(-0.99)}{-3.3}$	$\frac{-1.1(-1.3)}{-3.3}$
15.0	0.22	0.14	$\frac{-2.6(-2.57)}{-3.3}$	$\frac{-3.0(-2.9)}{-3.3}$
30.0	0.15	0.08	$\frac{-2.95(-2.86)}{-3.3}$	$\frac{-3.2(-3.09)}{-3.3}$

Note. The numerator contains experimental data; theoretical data obtained using (2) and taking into account ( $T_{pr}$ ) and (3) are given in brackets; the denominator contains data obtained using (2).

The table shows that the values  $\lg a_t$  obtained by the proposed procedure are close to experimental data while those data calculated by the WLF equation, have significant deviations and do not take into account the strain level and time. The changes in the concrete composition and structure, in the strain level at the same temperature and time of load action lead primarily to changing the value  $n_r$ . As a result, the material takes on the rheological properties that it would have when the temperature or time of load actions changes, i.e. in terms of rheological behaviour, the change of  $n_r$  due to a structure variation is similar to its change due to a variation of temperature or time of load action for the source material. This provision allows developing the concept of temperature-structural analogy (TSA).

Let's assume that the material at a temperature  $T_1$  and time of load action  $t_1$  has some value of properties  $E_1$  that corresponds to the quantity of elastic bonds  $n_{r1}$ . As the temperature is varied from  $T_1$  to  $T_2$ , the material properties are also varied. As a result, the material will have the same values of properties  $E_1$  at some time of load action  $t_2$ .

The difference between the factors of reduction to temperature  $T_2$  and  $T_1$  taking into account (3) is as follows:

$$\Delta \lg a_t^{T_{pr}} = \frac{-17.44 (T_2 - T_q)}{51.6 + (T_2 - T_q)} (1 - n_{r1}) + \frac{17.44 (T_1 - T_q)}{51.6 + (T_1 - T_q)} (1 - n_{r1}). \quad (6)$$

The same property values  $E_1$  at time of load action  $t_2$  can be obtained by keeping the temperature  $T_1$  but by changing the number of elastic bonds from  $n_{r1}$  to  $n_{r2}$  due to the material structure (e.g. by varying the amount of cement in the composite, binder modification, and etc.). This provision can be considered to be valid because the glass transition temperature is almost independent of the structure [17].

If the value of elastic bonds is varied from  $n_{r1}$  to  $n_{r2}$ , the difference between the reduction factors will be equal to:

$$\Delta \lg a_t^{T_{pr}} = \frac{-17.44 (T_1 - T_q)}{51.6 + (T_1 - T_q)} (1 - n_{r2}) + \frac{17.44 (T_1 - T_q)}{51.6 + (T_1 - T_q)} (1 - n_{r1}). \quad (7)$$

Considering the equality of dependencies (5) and (6) and having made some transformations, we will find:

$$T_2 = \frac{51.6A + T_q(1 - A)}{1 - A}, \quad (8)$$

where

$$A = \frac{(T_1 - T_q)(1 - n_{r2})}{[51.6 + (T_1 - T_q)](1 - n_{r1})}. \quad (9)$$

Formula (8) allows calculating the temperature equivalent ( $T_2 - T_1$ ) to the structural equivalent of the material ( $n_{r2} - n_{r1}$ ).

According to the TSA concept, it is possible to predict the properties of materials having a different composition within a wide range of temperatures and load time. For this purpose it is enough to obtain dependence of material properties of one composition on time of load action at a fixed temperature and strain, then obtain dependence  $n_{r2}$  on the material composition for one time of load action  $t_1$ . The value  $T_2$  is calculated using (8); and the value  $\Delta \lg a_t^{T_{pr}}$  is calculated by formula (7).

If experimentally obtained dependence  $\Delta \lg a_t^{T_{pr}}$  on the temperature with a certain value  $n_{r1}$ , then for using this dependence with other values  $n_{r2}$ , the reduction factor should be multiplied by the ratio  $(1 - n_{r2}) / (1 - n_{r1})$ .

The TSA concept can be used as a fundamental one in the design of concrete mixes on organo-hydraulic binders for certain conditions of their use based on the specified level of reliability (service life) of the road surface dressing (road pavement). Thus, there is a possibility to estimate the design characteristics of concretes on organo-hydraulic binders which values are difficult to find by direct experiment using a method of standard elementary tests, for example, elasticity modulus for various temperatures and time of load action  $E_{T(V)}$  [16] by formula (4).

For example, multi-year researches confirm the validity of the empirical dependence relating the value of the maximum structural strength ( $R_c$ ) to the maximum elasticity modulus ( $E_c$ ) within the entire range of temperature and time of load action:

$$E_c = 3,6 \cdot (16,3 \cdot R_c)^{1,9}. \quad (10)$$

Thus, using the principles of temperature-structural analogy, it is possible to predict the properties of composites based on organo-hydraulic binders as applied to the mechanistic and empirical methods of calculation for road pavements; as well as it is possible to calculate and directly adjust the long-term indicators of properties at the stage of concrete composition design. For example, the required value of elasticity modulus  $E_{V_1}$  at the time of load action  $V_1$  can be directionally adjusted while keeping the temperature conditions and the current load but changing the number of elastic bonds from  $n_{r1}$  to  $n_{r2}$ , i.e. due to the material structure (for example, by varying the amount of cement in the composition of bitumen cement composite binder).

**Conclusion.** For preparing the quality concretes during the regeneration process, RAP should be treated with complex organo-hydraulic binders. The received structure is very complex that is reflected in the behaviour of the received composite in a temperature-time field and by the estimation of its reliability and durability.

The main feature of the inter-contact interaction between the filler and the organo-hydraulic binder is poly-granularity and inhomogeneity of RAP in which the most part of grains are covered with an aged organic binder. Consequently, the majority of strong phase contacts of cement with the formation of continuous condensation-crystallization backbone is developed via the filler particles not coated with bitumen, as well as due to partial penetration of crystal whiskers into the bitumen films and during interaction of hydration products with active bitumen components on the surface of RAP-particles.

The concretes with a composite structure containing the thermodynamically incompatible binders have nonlinear viscoelasticity and are complex in their thermo-rheological properties. The reduction factor (the value of shifting the curves along the axis of time or strain rate) for such materials depends not only on the temperature but also on the material properties and the degree of strain condition.

As a result of studies performed, the concept of temperature-structural analogy is proposed. Along with the temperature and time factor, it takes into account the features of the structure described by the ratio of elastic and viscous bonds. The TSA concept allows obtaining necessary structural features for specific temperature-time factors. Using this concept, it is possible to predict the properties of composites based on OHB suitable for mechanistic and empirical methods of calculation of road pavements. As a result, it is possible to calculate the long-term indicators of properties at the stage of concrete composition design that determines the prerequisites for their directional adjustment.

It is necessary to take into account that an increase in cement content leads to an increase of strength properties and durability at an elastic stage of work; however, the resistance to dynamic impacts and cracks is decreased that reduces durability. In this regard, the proposed method to select the composition of concretes on OHB based on the optimal ratio of elastic and viscous bonds, taking into account the properties of RAP and the amount of cement, allows adjusting effectively the durability and reliability indicators.

**Acknowledgements.** This study was supported by Henan center for outstanding overseas scientists: [grant number GZS2018006].

**Б. М. Хрусталеv<sup>1,4</sup>, Т. Лю<sup>1,2,3</sup>, А. В. Бусел<sup>1,5</sup>, Ж. Ли<sup>1,3</sup>,  
В. А. Веренько<sup>1,4</sup>, В. В. Занкович<sup>1</sup>, Б. Шан<sup>2,3</sup>**

<sup>1</sup>Автомагистральдарды күтіп ұстау жөніндегі Гаююань Хэнань технологиялық компаниясы (Біліктілігі жоғары шетелдік мамандар орталығы), Синьсян, Қытай;

<sup>2</sup>Автомагистральдарды күтіп ұстауға арналған ұлттық инженерлік жабдықтар зертханасы, Синьсян, Қытай;

<sup>3</sup>Автомагистральдарды диагностикалау және күтіп ұстау бойынша Хэнань провинциясының негізгі зертханасы, Синьсян, Қытай;

<sup>4</sup>«Политехник» Беларусь ұлттық техникалық университеті Ғылыми-технологиялық паркі, Минск, Беларусь;

<sup>5</sup>«БелдорҒЗИ» «Беларус жол ғылыми-зерттеу институты» мемлекеттік кәсіпорны, Минск, Беларусь

#### **ӨНДЕЛГЕН АСФАЛЬТБЕТОНДЫ ЖОЛ ЖАМЫЛҒЫЛАРЫНАН АЛЫНҒАН ТҮЙІРШІКТЕР НЕГІЗІНДЕГІ КОМПОЗИТТЕРДІҢ ҚҰРЫЛЫМДЫҚ-МЕХАНИКАЛЫҚ ҚАСИЕТТЕРІН БОЛЖАУ ӘДІСТЕМЕСІ ЖӘНЕ БАҒАЛАУ**

**Аннотация.** Бұл мақалада асфальт түйіршіктері негізіндегі композиттердің беріктілік және деформативті қасиеттерін бағалаудың әдіснамалық ерекшеліктерін талдау және құрылым құру үдерістерін зерттеу нәтижелері берілген. Жаңа материалдар беріктілік пен сенімділіктің талап етілетін мәнін қамтамасыз етуге

мүмкіндік беретін олардың физикалық-механикалық сипаттамаларына объективті техникалық талаптарды әзірлеу мақсатында температура-уақыт өрісінде олардың әрекет ерекшеліктерін зерттеуді талап етеді.

Температура-уақыт аналогын қолданудың классикалық әдісі деформацияның шағын деңгейлерінде релаксациялық қисықтарды талдауға арналған сызықтық аймақта дұрыс. Мұндай жағдай оны композиттік материалды бұзу процесімен байланысты беріктік қасиеттері мен басқа да сипаттамаларын талдау үшін пайдалануға мүмкіндік бермейді. Құрамында термодинамикалық үйлеспейтін байланыстырғыш бар композициялық құрылым бетондары сызықсыз тұтқырлыққа ие және терморологиялық күрделі болып табылады. Композициялық материалдар үшін келтіру коэффициенті (қисықтардың уақыт осі бойымен жылжу шамасы немесе деформация жылдамдығы) температураға ғана емес, материалдың қасиеттеріне де, сондай-ақ кернеулі күй деңгейіне де байланысты болады. Бұл серпімді және тұтқыр байланыстардың кешенді жиынтығы бар жүйе ретінде композиттік материалдар құрылымының ерекшеліктерімен байланысты, осыған байланысты келтіру коэффициенті деформациялау процесіне тартылған серпімді байланыстардың санына байланысты.

Зерттеудің негізіне органикалық-гидравликалық тұтқыр композиттердің қасиеттерін болжауға мүмкіндік беретін температуралық-құрылымдық ұқсастық принциптері алынған. Бұл жол жамылғысының әр түрлі қабаттарын салуға арналған материалдардың құрамын жобалауға және алу технологиясын анықтауға мүмкіндік береді.

Жобалаудың ұсынылған әдістемелік принциптері асфальттүйіршіктердің қасиеттері мен цемент мөлшерін ескере отырып, серпімді және тұтқыр байланыстардың оңтайлы арақатынасын белгілеуге негізделген. Мұндай тәсілді пайдалану композиттердің барынша ұзақ мерзімділігіне қол жеткізу перспективасын, түрлі түрлендіргіш компоненттерді енгізудің мақсаттылығын және органикалық тұтқыр-тұтқыр шығынының оңтайлы шегін бағалауға мүмкіндік береді.

**Түйін сөздер:** асфальтбетонды регенерациялау, органикалық-гидравликалық байланыстырғыш композит, салқын регенерацияланған асфальтбетонды қоспа, циклдық ұзақ мерзімділік, температуралық-құрылымдық ұқсастық, реологиялық қасиеттер, максималды құрылымдық беріктік.

**Б. М. Хрусталеv<sup>1,4</sup>, Т. Лю<sup>1,2,3</sup>, А. В. Бусел<sup>1,5</sup>, Ж. Ли<sup>1,3</sup>,  
В. А. Веренько<sup>1,4</sup>, В. В. Занкович<sup>1</sup>, Б. Шан<sup>2,3</sup>**

<sup>1</sup>Хэнаньская технологическая компания Гаоюань по содержанию автомагистралей (Центр иностранных специалистов высокой квалификации), Синьсян, Китай;

<sup>2</sup>Национальная инженерная лаборатория оборудования для содержания автомагистралей, Синьсян, Китай;

<sup>3</sup>Ключевая лаборатория провинции Хэнань по диагностике и содержанию автомагистралей, Синьсян, Китай;

<sup>4</sup>Научно-технологический парк Белорусского национального технического университета «Политехник», Минск, Беларусь;

<sup>5</sup>Государственное предприятие «Белорусский дорожный научно-исследовательский институт «БелдорНИИ», Минск, Беларусь

## **ОЦЕНКА И МЕТОДИКА ПРОГНОЗИРОВАНИЯ СТРУКТУРНО-МЕХАНИЧЕСКИХ СВОЙСТВ КОМПОЗИТОВ НА ОСНОВЕ ГРАНУЛЯТОВ ИЗ ПЕРЕРАБОТАННЫХ АСФАЛЬТОБЕТОННЫХ ДОРОЖНЫХ ПОКРЫТИЙ**

**Аннотация.** В настоящей статье представлены результаты исследования процессов структурообразования и анализ методологических особенностей оценки прочностных и деформативных свойств композитов на основе асфальтогранулятов. Новые материалы требуют изучения особенностей их поведения в температурно-временном поле с целью выработки объективных технических требований к их физико-механическим характеристикам, позволяющих обеспечить требуемые значения прочности и надежности.

Классический способ применения температурно-временной аналогии справедлив в линейной области для анализа релаксационных кривых при небольших уровнях деформации или кривых ползучести при

небольших напряжениях. Такое положение не позволяет использовать его для анализа прочностных свойств и других характеристик, связанных с процессом разрушения композитного материала. Бетоны композиционной структуры с содержанием термодинамически несовместимых вяжущих, обладают нелинейной вязкоупругостью и являются термореологически сложными. Для композиционных материалов коэффициент приведения (величина смещения кривых вдоль оси времени или скорости деформации) зависит не только от температуры, но и свойств материала, а также уровня напряженного состояния. Связано это с особенностями структуры композитных материалов как системы с комплексным набором упругих и вязких связей, в связи с чем коэффициент приведения зависит от числа упругих связей, вовлеченных в процесс деформирования.

В основу исследования положены принципы температурно-структурной аналогии, позволяющие прогнозировать свойства композитов на органо-гидравлических вяжущих. Это позволяет направленно проектировать состав и определять технологию получения материалов для устройства различных слоев дорожных одежд.

Предложенные методологические принципы проектирования основаны на установлении оптимального соотношения упругих и вязких связей с учетом свойств асфальтогранулятов и количества цемента. Использование такого подхода позволяет оценивать перспективность достижения максимальной долговечности композитов, целесообразность введения различных модифицирующих компонентов и оптимальные пределы расхода органического вяжущего.

**Ключевые слова:** регенерация асфальтобетона, композит на органо-гидравлическом вяжущем, холодная регенерированная асфальтобетонная смесь, циклическая долговечность, температурно-структурная аналогия, реологические свойства, максимальная структурная прочность.

#### Information about authors:

Khroustalev B.M., Doctor of Engineering Science, Professor, Henan Gaoyuan Highway Maintenance Technology Co., Ltd (Henan Center for Outstanding Overseas Scientists); post@park.bntu.by; <https://orcid.org/0000-0002-4759-6302>

Veranko V.A., Doctor of Engineering Science, Professor, Expert of Henan Gaoyuan Highway Maintenance Technology Co., Ltd (Henan Center for Outstanding Overseas Scientists); verenko.vladimir@gmail.com; <https://orcid.org/0000-0002-5867-5540>

Liu T., Director General of Henan Gaoyuan Highway Maintenance Technology Co., Ltd; liutingguo@chngaoyuan.com; <https://orcid.org/0000-0002-0208-1276>

Busel A.V., Doctor of Engineering Science, Professor, State Enterprise "Belarusian Road Scientific and Research Institute «BeldorNII»"; bulex@tut.by; <https://orcid.org/0000-0003-1168-1780>

Zankavich V.V., Doctor of Science, Expert of Henan Gaoyuan Highway Maintenance Technology Co., Ltd (Henan Center for Outstanding Overseas Scientists); vitali.zankavich@chngaoyuan.com; <https://orcid.org/0000-0002-8115-2342>

Li Zh., Head of Henan Provincial Key Laboratory of Highway Detection and Maintenance; lizhongyu@chngaoyuan.com; <https://orcid.org/0000-0002-1135-3122>

Shang B., Researcher of the National Engineering Laboratory for Highway Maintenance Equipment; iver-sb@163.com; <https://orcid.org/0000-0002-3423-146X>

#### REFERENCES

[1] Vaitkus A., Gražulytė J., Juknevičiūtė Žilinskienė L., Andrejevas V. 2017. Review of Lithuanian Experience in Asphalt Pavements Cold Recycling, in *Proc. of the 10<sup>th</sup> International Conference «Environmental Engineering»*: selected papers. 27–28 April 2017, Vilnius, Lithuania. Vilnius Gediminas Technical University. <https://doi.org/10.3846/enviro.2017.153> (in Eng.).

[2] Veranko V.A., Makarevich A.A. 2008. Experience of using in-situ cold recycling technology when repair of streets of the Minsk city. *Automobile roads and bridges* N 1 (2008): 13-18. (in Russ.)

[3] Jähren C.T., Ellsworth B.J., Cawley B., Bergeson K. 1998. *Review of Cold In-Place Recycled Asphalt Concrete Projects*. Iowa DOT Project HR-392. Ames: Iowa State University. 46 p. (in Eng.).

[4] Teltaev B. 2014. Evaluation of low temperature cracking indicators of hot mix asphalt pavement, *International Journal of Pavement Research and Technology* 7(5): 343-351 (in Eng.).

- [5] Teltaev B., Radovskiy B. 2016. Low temperature cracking problem for asphalt pavements in Kazakhstan, *RILEM Bookseries* 13: 139-144 (in Eng.).
- [6] Teltaev B., Radovskiy B. 2018. Predicting thermal cracking of asphalt pavements from bitumen and mix properties, *Road Materials and Pavement Design* 19(8): 1832-1847 (in Eng.).
- [7] Mollenhauer K., Simnofske D., Valentin J., Čížková Z., Suda J., Batista F., McNally C. 2016. Mix designs for cold recycled pavement materials considering local weather and traffic conditions, in *Proc. of 6<sup>th</sup> Eurasphalt & Eurobitume Congress: selected papers*, 1-3 June 2016. Prague, Czech Republic. Czech Technical University in Prague. <https://dx.doi.org/10.14311/EE.2016.357> (in Eng.).
- [8] Ayar P. 2018. Effects of additives on the mechanical performance in recycled mixtures with bitumen emulsion: An overview, *Construction and Building Materials* 178: 551-561. <https://doi.org/10.1016/j.conbuildmat.2018.05.174> (in Eng.).
- [9] Lin J., Hong J., Xiao Y. 2017. Dynamic characteristics of 100% cold recycled asphalt mixture using asphalt emulsion and cement, *Journal of Cleaner Production* 156: 337-344. <https://doi.org/10.1016/j.jclepro.2017.04.065> (in Eng.).
- [10] Tabaković A., McNally C., Fallon E. Specification development for cold in-situ recycling of asphalt, *Construction and Building Materials* 102: 318-328. <https://doi.org/10.1016/j.conbuildmat.2015.10.154> (in Eng.).
- [11] Kim Y., Lee H.D. 2006. Development of mix design procedure for cold in-place recycling with foamed asphalt, *Journal of Materials in Civil Engineering* 18(1): 116-124. [https://doi.org/10.1061/\(ASCE\)0899-1561\(2006\)18:1\(116\)](https://doi.org/10.1061/(ASCE)0899-1561(2006)18:1(116)) (in Eng.).
- [12] Meocci M., Grilli A., La Torre F., Bocci M. 2017. Evaluation of mechanical performance of cement-bitumen-treated materials through laboratory and in-situ testing, *Road Materials and Pavement Design* 18: 376-389. doi:10.1080/14680629.2016.1213506 (in Eng.).
- [13] Valentin J., Suda J., Zak J. 2015. *Report on Durability of cold-recycled mixes: Complex dynamic modulus and master curves of cold recycling mixes*. CEDR Transnational Road Research Programme Call 2012: Recycling: Road construction in a post-fossil fuel society. Czech Technical University in Prague. 19 p. doi: 10.13140/RG.2.1.3439.6327 (in Eng.).
- [14] Lee H., Kim Y. 2007. *Validation of the mix design process for cold in-place rehabilitation using foamed asphalt*. Final Report (IHRB Project TR 474). Public policy center civil and environmental engineering university of Iowa. 234 p. Available from Internet: <http://publications.iowa.gov/id/eprint/5311> (in Eng.).
- [15] Gandi A., Carter A., Singh D. 2018. Effect of binder type on Full Depth Reclamation material behavior, *International Journal of Pavement Research and Technology*. 11 p. <https://doi.org/10.1016/j.ijprt.2018.08.005> (in Eng.).
- [16] Li Z., Liu T., Shi J., Veranko U., Zankavich V. Fatigue resistance of asphalt concrete pavements. Peculiarity and assessments of potentials, *The Baltic Journal of Road and Bridge Engineering* XII (4): 270-275. <http://dx.doi.org/10.3846/bjrbe.2017.34> (in Eng.).
- [17] Veranko V.A. 1993. *Road composite materials. Structure and mechanical properties*. Science and Technology. Minsk. 246 p. (in Russ.).
- [18] Veranko V.A. 1998. Road concretes based on organo-hydraulic binders (Theory and practical using): Abstract of dissertation for the degree of Doctor of Technical Sciences, Belarusian State Polytechnical Academy, Minsk. 40 p. (in Russ.).
- [19] JTG F41-2008 公路沥青路面再生技术规范[Technical Specifications for Highway Asphalt Pavement Recycling]. Chinese Standard. Available from Internet: <http://www.gxgtzx.com/upload/files/201711/15095874957748.pdf> (in Eng.).
- [20] Williams M.L., Landel R.F., Ferry J.D. 1955. The Temperature Dependence of Relaxation Mechanisms in Amorphous Polymers and Other Glass-forming Liquids, *Journal of the American Chemical Society* 77 (14): 3701-3707. doi: 10.1021/ja01619a008. (in Eng.).
- [21] Veranko V.A., Makarevich A.A. 2010. Prediction of design characteristics of concretes based on organo-hydraulic binders in wide ranges of temperatures and deformation rates, *Bulletin of Belorussian National Technical University: scientific and technical journal* 3. 20-27. ISSN 2414-0392 (in Russ.).

## Юбилейные даты

---

---

### ***LIFE GIVEN TO SCIENCE*** *(on the occasion of the 90th birthday* *of the pioneer of paleozoological research in Kazakhstan)*



Kazakhstan is a storehouse of unique underground wealth, which stores paleontological organics, which are the remains of the ancient plant and animal world. They are unique scientific value, because geographically the territory of the republic occupies central place in Eurasia, and the articulation and separation of the various paleobasins of the Phanerozoic has repeatedly occurred in its territory.

Large discoveries (with skeletal remains of ancient vertebrates) were made at the beginning of the twentieth century of the previous millennium by Russian scientists in the Torgai depression, the Northern Aral Sea region, in the Irtysh region and in other regions. Dozens of scientific discoveries have been made on these materials that have brought world fame to Kazakhstan. In this regard, the territory of Kazakhstan has become a full-fledged scientific training ground for paleontological research since the beginning of the previous century, and the skeletal material of ancient animals mined at that time is an adornment of the expositions of the paleontological museums of Moscow and St. Petersburg, then later in Almaty. These discoveries contributed to the creation of specialized scientific organizations and the development of paleontological research in Kazakhstan only in the 50s of the previous century. These studies were associated with the beginning of large-scale work on geological surveys and, accordingly, with the training at universities of the country of specialists - geologists and paleontologists to study various groups of extinct plant and animal organisms. It was a time when a large school of highly qualified specialists of paleozoologists and paleobotanists created in Kazakhstan, under the guidance of doctors of biological sciences V.S. Bazhanov and V.S. Kornilova. And among them, the first graduate student of V.S. Bazhanov was B.S. Kozhamkulova, who later became a major and one of the leading experts in the study of vertebrates in Kazakhstan from the Pleistocene era.

On March 30, 2020, Baldyrgan Seralieva Kozhamkulova, a Kazakh scientist, one of the pioneers of paleozoological science, would have turned 90 years old. Her entire creative life from her student years was connected with scientific research.

B.S. Kozhamkulova was born on March 30, 1930 in Alma-Ata in the family of the famous People's Artist of the USSR and Kazakhstan, Hero of the Socialist Labor of the USSR Serke Kozhamkulov. In

1954 she graduated from Kazakh State University named after S.M. Kirov (now KazNU named after Al-Farabi). In 1954-1957 graduate student of the Institute of Zoology of the Academy of Sciences of the Kazakh SSR. In 1964 she defended her thesis on the topic "Overview of the anthropogenic fossil theriofauna of Kazakhstan." Kozhamkulova Baldyrgan Seralievna, with her studies of vertebrates of the Late Cenozoic of Kazakhstan on their taxonomic biodiversity, paleofauna, paleozoogeography, made a great contribution to the history of the formation of modern fauna of vertebrates and biostratigraphy of the Pleistocene sediments of Kazakhstan.

From 1964 to 1986 she was head of the Laboratory of Paleobiology, Institute of Zoology, Academy of Sciences of the Kazakh SSR.

In general, it was the stage of the heyday, development and establishment of paleontological research and the widespread use of laboratory achievements in the practice of geological services under her leadership from the 50s to the 90s for the paleontological science of Kazakhstan. From 1966-1986 B.S. Kozhamkulova is the scientific leader of five-year fundamental research projects of the laboratory. She contributed in every possible way to the preparation of large-scale research work on scientific cooperation agreements both at the republican and union, as well as at the international level.

From 1982-1986 she was a corresponding member of the sub-commission on the Quaternary Stratigraphy of Europe. 1986-1990 – she is leading researcher at the paleobiology laboratory of the Institute of Zoology of the Academy of Sciences of the Kazakh SSR. 1990-1996 – she is scientific consultant of the Paleontology Sector of the Central State Museum of the Republic of Kazakhstan.

She discovered paleolithic sites with skeletal remains of mammoths in Western Siberia, Volch'ya griva (=Wolf Mane). The second Late Paleolithic site is Aktas (Zerendinsky district of the Kokchetav region). She was the first to single out the Kazakhstan - South Ural paleozoogeographic province for the distribution of Siberian elasmotherium.

For the first time, regional cadastres of mammoth fauna of Kazakhstan were compiled at many locations for the All-Union cadastre of reference locations of mammoth fauna. For the first time, original maps of the distribution of ancient animals with an image of their appearance in complexes from the Late Pliocene to the Holocene were presented. According to these data, she posthumously co-authored a reference book for future paleontologists "Locations of Fossil Vertebrates of the Phanerozoic of Kazakhstan" - 2017 edition.

She traced the developmental stages of the Late Cenozoic ungulates of Kazakhstan, characterizing the six stratigraphic units of the regional geological scale and compares the anthropogenic faunistic complexes of Kazakhstan with similar complexes of Eastern Europe, Central Asia, Western and Eastern Siberia, Transbaikalia and the Far East; developed a scheme "Stratigraphic distribution of complexes of anthropogenic mammals in Kazakhstan".

Over 170 scientific papers have been published, among which are well known: "Anthropogenic fossil theriofauna of Kazakhstan" (1969), "Late Cenozoic ungulates of Kazakhstan" (1981), "Extinct animals of Kazakhstan" (1984). Co-author of the "Catalog of Cenozoic mammals of Kazakhstan" (1989). Under her editing, V-X volumes of laboratory works from the series "Materials on the History of Fauna and Flora of Kazakhstan", the monograph "Late Neogene Fauna of the South-East of Kazakhstan" and the collection "News of the Paleobotany of Kazakhstan" were published. Thanks to her contribution, three paleontological reserves were legislatively approved: "Goose Flight" with the remains of the hipparion fauna on the river bank Irtysh in the vicinity of Pavlodar; "Aulie" with the remains of the Jurassic fauna and flora in the Karatau mountains within the territory of the Aksu-Dzhabaglinsky reserve; "Koshkurgan" with the Early Pleistocene koshkurgan faunistic complex of large mammals in the Shymkent region. Its role in the popularization of paleontological research in Kazakhstan is known by the publication of three issues of bibliographic indexes of scientific works of Kazakhstani paleontologists on invertebrates and vertebrates (1976, 1996, 1999). "Instructions for collecting the remains of fossil vertebrates and higher plants during geological work", published in collaboration with V.S. Bazhanov and V.V. Kuznetsov (1974); "The Handbook of Specialists in Paleontological Research in Kazakhstan" (1994); "Kazakhstan dinosaurs: land, flying and marine" (1999); "Mammoth fauna of Akmola region (2009)". By order of the mammoth committee of the Zoological Academy of Sciences of the USSR B.S. Kozhamkulova compiled regional cadastres of mammoth fauna of Kazakhstan for the All-Union cadastre of reference locations of mammoth fauna. Systematized and generalized research data by B.S. Kozhamkulova on the Late Cenozoic sediments of Kazakhstan and the adjacent territories of the Central Asian republics was used by N. N. Kostenko

when compiling the “Map of the Quaternary sediments of Kazakhstan and the adjacent territories of the Union Republics”, published on a scale of 1: 1,500,000. The results of many years of work by B. S. Kozhamkulova were used in various monographs and articles of geologists, where its data are cited to confirm the geological age of continental deposits and the conditions of their formation, to clarify stratigraphic units, and also in the process of geological survey and prospecting work related to Pliocene-Quaternary sediments.

B.S. Kozhamkulova repeatedly made presentations at international congresses, colloquiums, symposia, republican and all-union conferences (Brno, Helsinki, Rome, Moscow, Leningrad, Odessa, Dushanbe, Krasnoyarsk, Alma-Ata, Turkestan, etc.) She has published over 50 popular science articles and articles in newspapers and magazines. Her contribution to the creation of museum expositions of the Museum of Nature of RSE “Gylym Ordasy”, which until 2010 administratively belonged to the Institute of Zoology of the Academy of Sciences of the Kazakh SSR, was also important.

As a result of her first field research in the 50s of the previous century, the skeletal remains of the Jurassic Pliosaurus from Western Kazakhstan, as well as the complete mammoth skeleton from the southwestern part of Western Siberia, which became the hallmark of the museum, were delivered to the laboratory. Later, the materials of her research also replenished the Pleistocene museum windows on elasmotherium, fossil horses, camels and other types of ancient vertebrates. From 1959 to 1996 she was a full member of the All-Union Paleontological Society. Full member of the "Bureau of the Committee for the Study of Mammoths and Mammoth Fauna of the USSR", a member of the Kazakhstan Regional Interdepartmental Stratigraphic Commission, All-Union Paleontological Society, All-Union Theriological Society and Moscow Society of Naturalists. From 1974-1984 – she is Project Manager of the International Geological Correlation Program (IGCP) of UNESCO No. 41 “Neogene / Quarter Border”; Project No. 24 of the IGCP of UNESCO “Quaternary Glaciations of the Northern Hemisphere”; “Geological events in the Cenozoic of the Urals in the light of global changes in the geosphere and biosphere”; “Revision and detailing of the stratigraphic diagram of the Pleistocene of the Urals and its magnetostratigraphy (from the Pre-Caspian Sea to Pechora, 1981-1985)”, being both the supervisor of the section “Systematization of finds of mammalian remains in the Bashkir Autonomous Soviet Socialist Republic”.

From 1974 to 1989 B.S. Kozhamkulova was used in the reports of the Cenozoic stratigraphy laboratory of the Institute of Geology of the BFAN of the USSR. Since 2002 - Honorary reader of the Central Scientific Library of NAS RK. She was a member of the Academic Council for the defense of dissertations at the Institute of Zoology of the Academy of Sciences of the Kazakh SSR and the Central State Museum of Kazakhstan. Under her leadership, diploma and candidate dissertations were defended, as well as internships for young specialists from Russia, Buryatia, Bashkiria and Central Asia on Quaternary fauna, as well as research workers from the regional museums of Kazakhstan and Bashkiria.

From 1964 to 1988, she was a member of scientific councils on the problems of “Animal kingdom of Kazakhstan”, “Ways and patterns of historical development of animals and plant organisms”, PIN Academy of Sciences of the USSR, Moscow, “Comprehensive study and development of mountainous areas of Central Asia and Kazakhstan,” member Bureau of the Committee for the Study of Mammoth Fauna –ZIN AN USSR, Leningrad. As a result, we can say that Baldyrgan Seralieвна Kozhamkulova stood at the origins of the Quaternary Paleontology of Kazakhstan. Her works, widely known both in the republics of the former USSR and abroad, served as the basis for the creation of regional and interregional stratigraphic schemes of the late Cenozoic of Eurasia. She remained forever in her writings. Huge contribution B.S. Kozhamkulova in paleontology and stratigraphy of Kazakhstan will forever remain in demand in science and will be used in further studies of her followers.

For successful, fruitful work in the field of science, she has received awards and diplomas from the Presidium of the Academy of Sciences of Kazakhstan, the Institute of Zoology of the Academy of Sciences of the National Academy of Sciences of the Republic of Kazakhstan, and the Medal in honor of the 60th anniversary of Victory Day in the Great Patriotic War (1941-1945).

*Tleuberdina P.A.,  
Nazymbetova G.Sh.*

## **ЖИЗНЬ, ОТДАННАЯ НАУКЕ**

*(к 90-летию со дня рождения  
первопроходца палеозоологических исследований в Казахстане)*

Казахстан представляет собой кладовую уникальных подземных богатств, в которой хранится палеонтологическая органика, представляющая собой остатки древнего растительного и животного мира. Они представляют уникальную научную ценность, поскольку географически территория республики занимает центральное место в Евразии и на ее территории неоднократно происходило сочленение и разъединение различных палеобассейнов фанерозоя. Крупные открытия (со скелетными остатками древних позвоночных) были сделаны еще в начале XX столетия прошлого тысячелетия российскими учеными в Торгайской впадине, Северном Приаралье, в Прииртышье и в др. регионах. На этих материалах были сделаны десятки научных открытий, которые принесли мировую известность Казахстану. В связи с этим территория Казахстана с начала прошлого столетия стала полноценным научным полигоном для палеонтологических исследований, а добытый по тем временам скелетный материал по древним животным является украшением экспозиций палеонтологических музеев Москвы и Санкт-Петербурга, затем и позднее Алматы. Эти открытия способствовали созданию специализированных научных организаций и развитию палеонтологических исследований в Казахстане только в 50-х годах прошлого столетия. Эти исследования были также связаны с началом широкомасштабных работ по проведению геологической съемки и соответственно с подготовкой в вузах страны специалистов – геологов и палеонтологов по изучению различных групп вымерших растительных и животных организмов. Это было время, когда в Казахстане под руководством докторов биологических наук В.С. Бажанова и В.С. Корниловой была создана большая школа высококвалифицированных специалистов палеозоологов и палеоботаников. И среди них первым аспирантом В.С.Бажанова стала Б.С. Кожамкулова, которая впоследствии стала крупным и одним из ведущих специалистов в изучении позвоночных Казахстана эпохи плейстоцена.

30 марта 2020 года Балдырган Сералиевне Кожамкуловой – казахстанскому ученому, одному из первопроходцев палеозоологической науки исполнилось бы 90 лет. Вся ее творческая жизнь со студенческих лет была связана с научными исследованиями.

Б.С. Кожамкулова родилась 30 марта 1930 года в г. Алма-Ате в семье известного народного артиста СССР и Казахстана, Героя Социалистического труда СССР Серке Кожамкулова. В 1954 г. закончила КазГУ им. С. М. Кирова (ныне КазНУ им. аль-Фараби). В 1954-1957 гг. аспирант Института зоологии АН КазССР. В 1964 г. защитила кандидатскую диссертацию на тему «Обзор антропогенной ископаемой териофауны Казахстана». Кожамкулова Балдырган Сералиевна своими исследованиями позвоночных позднего кайнозоя Казахстана по вопросам их таксономического биоразнообразия, палеофаунистики, палеозоогеографии внесла большой вклад в познание истории формирования современной фауны позвоночных и биостратиграфии плейстоценовых отложений Казахстана.

С 1964 по 1986 гг. она возглавляла лабораторию палеобиологии Института зоологии АН КазССР. В целом под ее руководством период с 60-х до 90-х годов для палеонтологической науки Казахстана – был этап расцвета, развития и становления палеонтологических изысканий и широкого применения достижений лаборатории в практике геологических служб. С 1966-1986 гг. Б.С. Кожамкулова – научный руководитель пятилетних проектов по фундаментальным исследованиям лаборатории. Всемирно содействовала подготовке широкомасштабных научно-исследовательских работ по договорам о научном сотрудничестве как на республиканском и союзном, так и на международном уровне. С 1982-1986 гг. годы она – член-корреспондент подкомиссии по четвертичной стратиграфии Европы. 1986-1990 гг. – ведущий научный сотрудник лаборатории палеобиологии Института зоологии АН КазССР. 1990-1996 гг. – научный консультант Сектора палеонтологии Центрального государственного музея РК.

Ею открыты палеолитические стоянки со скелетными остатками мамонтов в Западной Сибири (Волчья грива). Вторая позднепалеолитическая стоянка – Актас (Зерендинский район Кокчетавской области). Ею впервые была выделена Казахстанско-Южно-Уральская палеозоогеографичес-

кая провинция по распространению сибирского эласмотерия. Впервые составлены региональные кадастры мамонтовой фауны Казахстана по многим местонахождениям для Общесоюзного кадастра реперных местонахождений мамонтовой фауны. Впервые представлены оригинальные карты распространения древних зверей с изображением их внешнего вида по комплексам от позднего плиоцена до голоцена. Согласно этим данным она посмертно стала соавтором книги-справочника для будущих палеонтологов «Местонахождения ископаемых позвоночных фанерозоя Казахстана» – издание 2017 года. Ею впервые прослежены этапы развития позднекайнозойских копытных Казахстана, характеризующих шесть стратиграфических подразделений региональной геологической шкалы и дано сопоставление антропогенных фаунистических комплексов Казахстана с подобными комплексами Восточной Европы, Средней Азии, Западной и Восточной Сибири, Забайкалья и Дальнего Востока; разработана схема «Стратиграфическое распространение комплексов антропогенных млекопитающих на территории Казахстана».

Опубликовано более 170 научных трудов, среди которых хорошо известны: «Антропогенная ископаемая териофауна Казахстана» (1969), «Позднекайнозойские копытные Казахстана» (1981), «Вымершие животные Казахстана» (1984). Соавтор «Каталога кайнозойских млекопитающих Казахстана» (1989). Под её редакцией изданы V-X тома трудов лаборатории из серии «Материалы по истории фауны и флоры Казахстана», монография «Позднеогеновая фауна юго-востока Казахстана» и сборник «Новости палеоботаники Казахстана». Благодаря ее вкладу законодательно были утверждены три палеонтологических заповедника: «Гусиный перелет» с остатками гиппариновой фауны на берегу р. Иртыш в окрестностях г. Павлодара; «Аулие» с остатками юрской фауны и флоры в горах Каратау в пределах территории Аксу-Джабаглинского заповедника; «Кошкурган» с раннеплейстоценовым кошкурганским фаунистическим комплексом крупных млекопитающих в Шымкентской области. Известна ее роль в популяризации палеонтологических исследований в Казахстане изданием трех выпусков библиографических указателей научных трудов казахстанских палеонтологов по беспозвоночным и позвоночным животным (1976, 1996, 1999). Ею изданы три выпуска библиографических указателей научных трудов казахстанских палеозоологов как по беспозвоночным, так и по позвоночным животным (1976, 1996, 1999); «Инструкции по сбору остатков ископаемых позвоночных животных и высших растений при геологических работах», изданной в соавторстве с В.С. Бажановым и В.В. Кузнецовым (1974); «Справочника специалистов по палеонтологическим исследованиям в Казахстане» (1994); «Казахстанские динозавры: сухопутные, летающие и морские» (1999); «Мамонтовая фауна Акмолинской области (2009)». По заданию мамонтового комитета ЗИН АН СССР Б.С. Кожамкуловой были составлены региональные кадастры мамонтовой фауны Казахстана для Общесоюзного кадастра реперных местонахождений мамонтовой фауны. Систематизированные и обобщенные данные исследований Б.С. Кожамкуловой по позднекайнозойским отложениям Казахстана и прилежащих территорий республик Средней Азии использованы Н.Н.Костенко при составлении «Карты четвертичных отложений Казахстана и прилежащих территорий союзных республик», изданной в масштабе 1:1500000. Результаты многолетних работ Б.С. Кожамкуловой использованы в различных монографиях и статьях геологов, где ее данные цитируются для подтверждения геологического возраста континентальных отложений и условий их формирования, для уточнения стратиграфических подразделений, а также в процессе геолого-съёмочных и поисковых работ, связанных с плиоцен-четвертичными отложениями.

Б.С. Кожамкулова неоднократный участник с докладами на Международных конгрессах, коллоквиумах, симпозиумах, республиканских и всесоюзных конференциях (Брно, Хельсинки, Рим, Москва, Ленинград, Тбилиси, Киев, Кишинев, Одесса, Душанбе, Красноярск, Алма-Ата, Туркестан и др.)

Ею опубликовано более 50 научно-популярных статей и заметок в газетах и журналах. Немаловажен и ее вклад в создание музейных экспозиций Музея природы РГП «Ғылым ордасы», который до 2010 года административно относился к Институту зоологии АН КазССР. В результате ее первых полевых исследований в 50-х годах прошлого столетия в лабораторию были доставлены скелетные останки юрского плиозавра из Западного Казахстана, а также полный скелет мамонта из юго-западной части Западной Сибири, которые стали визитной карточкой музея. Позднее материалы ее исследований также дополнили плейстоценовые витрины музея по эласмотерии, ископаемым лошадям, верблюдам и другими видами древних позвоночных.

С 1959 по 1996 она являлась действительным членом Всесоюзного палеонтологического общества. Действительный член «Бюро комитета по изучению мамонтов и мамонтовой фауны СССР», членом Казахстанской Региональной Межведомственной Стратиграфической Комиссии, Всесоюзного Палеонтологического Общества, Всесоюзного Териологического Общества и Московского Общества Испытателей Природы. С 1974-1984 гг. – руководитель по Проектам Международной Программы Геологической Корреляции (МПК) ЮНЕСКО № 41 «Граница неоген/квартера»; проекта № 24 МПК ЮНЕСКО «Четвертичные оледенения Северного Полушария»; «Геологические события в кайнозое Предуралья в свете глобальных изменений в геосфере и биосфере»; «Ревизия и детализация стратиграфической схемы плейстоцена Предуралья и его магнитостратиграфия (от Прикаспия до Печоры, 1981-1985)», являясь одновременно научным руководителем по разделу «Систематизация находок остатков млекопитающих в Башкирской АССР». С 1974 по 1989 гг. работы Б.С. Кожамкуловой была использована в отчетах лаборатории стратиграфии кайнозоя Института геологии БФАН СССР. Она была членом Ученого Совета по защитах диссертаций при Институте зоологии АН КазССР и Центрального Государственного музея Казахстана. С 2002 – Почетный читатель Центральной научной библиотеки НАН РК. Под ее руководством защищены дипломные и кандидатские диссертации, а также проходили стажировки молодые специалисты из России, Бурятии, Башкирии и Средней Азии по четвертичной фауне, а также научные сотрудники областных музеев Казахстана и Башкирии.

С 1964 по 1988 гг. она являлась членом научных советов по проблемам «Животный мир Казахстана», «Пути и закономерности исторического развития животных и растительных организмов» – ПИН АН СССР, Москва, «Комплексное изучение и освоение горных территорий Средней Азии и Казахстана», членом бюро Комитета по изучению мамонтовой фауны – ЗИН АН СССР, Ленинград.

В итоге можно сказать, что Балдырган Сералиевна Кожамкулова стояла у истоков Четвертичной палеонтологии Казахстана. Её работы, широко известные как в республиках бывшего СССР, так и за рубежом, служили основой для создания региональных и межрегиональных стратиграфических схем позднего кайнозоя Евразии. Она навечно осталась в своих трудах. Огромный вклад Б.С. Кожамкуловой в палеонтологию и стратиграфию Казахстана навсегда останется востребованным в науке и будет использован в дальнейших исследованиях её последователей.

За успешную, плодотворную работу в области науки имеет награды, грамоты Президиума Академии наук Казахстана, Института зоологии АН НАН РК, Медаль в честь 60-летия Дня Победы в Великой Отечественной войны (1941-1945).

**МАЗМҰНЫ**

<i>Бейсембетов Е.Қ., Бекібаев Т.Т., Жанбасбаев Ұ.Қ., Рамазанова Г.И., Панфилов М.</i> «Қазтрансойл» АҚ мұнайын тасымалдау бойынша SmartTran бағдарламалық жасақтамасы.....	6
<i>Абдуллаев А.У., Юсупов Ш.С.</i> Комплекстік сейсмогидрогеохимиялық мониторингтің сандық көрсеткіштерін күшті жер сілкіністерін болжау мақсатында оңтайландыру.....	14
<i>Абетов А.Е., Волож Ю.А., Ниязова А.Т.</i> Солтүстік Үстірт өңірінің ірі геокұрылымдарының құрылымдық элементтерінің корреляциясы.....	21
<i>Байбатша Ә.Б., Мушинский А.</i> Арғанаты ауданы болжамдық бөлікшелерінің геологиялық-геофизикалық іздеу белгілері (Шығыс Балқашманы).....	31
<i>Бигараев Ә.Б., Мусина Э.С.</i> Солтүстік Қазақстан шөгінді бассейнінің геологиялық құрылымы, зерттелу жағдайы және мұнайгаз перспективасы.....	40
<i>Босак П.В., Попович В.В., Степовая Е.В., Дудин Р.Б.</i> Шахта тамшыларының токсикологиялық сипаттары Львов-Волын тас көмірі және олардың қоршаған ортаға әсер етуі.....	48
<i>Гончаренко Д.Ф., Алейникова А.И., Убийвовк А.В.</i> Қалдықтармен жұмыс істейтін кен орындарына қосылу алаңында кептіру туннельдерін қайта құру әдісін дамыту.....	55
<i>Судаков А., Дреус А., Ратов Б., Судакова О., Хоменко О., Дзюба С., Судакова Д., Муратова С., Ауезбай М.</i> Ұңғыларды бұрғылаудың горизонттарын изоляциялаудың термомеханикалық технологиясының параметрлерін пайдалану.....	63
<i>Ефименко В.Н., Ефименко С.В., Телтаев Б.Б., Сухоруков А.В.</i> Жол төсемелерін жобалау кезінде сазды топырақтардың қасиеттерін саралап есепке алу қажеттілігі туралы.....	72
<i>Қасенов А.Қ., Сыздықов А.Х., Спирич В.И., Молдабеков М.С., Бөкенова М.С.</i> Мұнайгаз ұңғыларын тазалауға арналған Satbayev University құрылғысы үшін кавитаторларды есептеу әдістемесі.....	81
<i>Кенжалиев Б., Есимова Д.М., Суркова Т.Ю., Сумовидагдо А., Аманжолова Л.У., Егоров Н.Б.</i> Үрдісте өнімді ерітіндідегі рН өзгеруіне қарай, сирек кездесетін және кірме элементтер қосылыстарының өзгертілуі.....	87
<i>Корнев В.А., Макенов А.А., Машекенова А.Х., Раджабов Р.К.</i> Автомобильдің күрделі жүйелерінің жұмысқа қабілеттілігінің мультікөрсеткіштік бақылауының сапасын бағалау.....	96
<i>Лагутин Е.И., Смоляр В.А., Кожобаев К.А., Терехов А.Г., Едігенов М.Б.</i> Маңызды гидрогеологиялық карталар.....	103
<i>Муртазин Е.Ж., Мирошниченко О.Л., Трушель Л.Ю., Смоляр В.А., Мирлас В.М.</i> Қазақстанның жерасты суларымен қамтамасыз ету картасының компьютерлік пішіндерін құрастыру.....	114
<i>Мұстафаев Ж.С., Қозыкеева Ә.Т., Калмашова А.Н., Алдиярова А.Е., Повилайтис Арвидас</i> Есіл өзенінің су жинау алабын экологиялық-су шаруашылық тұрғыда бағалау.....	123
<i>Оситов С.В., Ерменбай А.М., Ақылбекова А.Ж., Ливинский Ю.Н., Анарбеков Ойторе</i> Антропогендік факторлардың Қазақстандағы жер асты суларының жағдайына теріс әсері.....	132
<i>Расулов С.Р., Гасанов Г.Т., Зейналов А.Н.</i> Мұнай ұңғымасындағы реологиялық меншіктердің акустикалық диагностикасы.....	141
<i>Солоненко В. Г., Махметова Н.М., Николаев В.А., Кваинин М.Я., Базанова И.А., Джолдасова К.К.</i> Поезд салмақ күшінің түсу нүктесінің бүйір күштің шамасына әсері.....	148
<i>Ключко Р.Н., Джумашиев Ф.С.</i> Шартты-ерте сынақтан өтетін жеке тұлғаларға арналған пробация бақылауы.....	156
<i>Тайсарина А.С., Телтаев Б.Б., Лопренчиче Д., Ибрагимова Н.А.</i> Экономикалық, автомобиль жолы, көлік және логистикалық көрсеткіштер арасындағы өзара байланысты талдау.....	162
<i>Тарихазер С.А.</i> Солтүстік-шығыс дінінің морфометрикалық талдау туризм потенциалдық мақсаты үшін Ұлы Қауказдың аясы (ГАЗ технологиясын қолдану).....	170
<i>Ходжибергенев Д.Т., Уралов Б.К., Воеводин Е.П., Абдукаримов А., Абсадыков Б.Н.</i> Бұрғылау процесі кинематикасының ерекшеліктері.....	178
<i>Хрусталев Б.М., Лю Т., Бусел А.В., Ли Ж., Веренько В.А., Занкович В.В., Шан Б.</i> Өңделген асфальтбетонды жол жамылғыларынан алынған түйіршіктер негізіндегі композиттердің құрылымдық-механикалық қасиеттерін болжау әдістемесі және бағалау.....	187
<b>Мерейтойлар</b>	
Ғылымға арналған өмір.....	198

## СОДЕРЖАНИЕ

<i>Бейсембетов И.К., Бекибаев Т.Т., Жапбасбаев У.К., Рамазанова Г.И., Панфилов М.</i> Программное обеспечение SmartTran по транспортировке нефти АО «Казтрансойл».....	6
<i>Абдуллаев А.У., Юсупов Ш.С.</i> Оптимизация количественных показателей комплексного сейсмогидрогеохимического мониторинга с целью прогноза сильных землетрясений.....	14
<i>Абетов А.Е., Волож Ю.А., Ниязова А.Т.</i> Корреляция структурных элементов крупных геоструктур Северо-Устьюртского региона.....	21
<i>Байбатша А.Б., Мушинский А.</i> Геолого-геофизические поисковые признаки прогнозных участков района Арганаты (Восточное Прибалхашье).....	31
<i>Бигараев А.Б., Мусина Э.С.</i> Состояние изученности, особенности геологического строения и перспективы нефтегазоносности Северо-Казахстанского осадочного бассейна.....	40
<i>Босак П.В., Попович В.В., Степовая Е.В., Дудин Р.Б.</i> Токсикологические свойства отвалов шахтных пород Львовско-Волынского каменноугольного бассейна и их влияние на окружающую среду.....	48
<i>Гончаренко Д.Ф., Алейникова А.И., Убийвовк А.В.</i> Разработка метода восстановления канализационных тоннелей в местах примыкания к смотровым шахтам.....	55
<i>Судаков А., Дреус А., Ратов Б., Судакова О., Хоменко О., Дзюба С., Судакова Д., Муратова С., Аязбай М.</i> Обоснование параметров термомеханической технологии изоляции поглощающих горизонтов буровых скважин.....	63
<i>Ефименко В.Н., Ефименко С.В., Телтаев Б.Б., Сухоруков А.В.</i> О необходимости дифференцированного учёта свойств глинистых грунтов при проектировании дорожных одежд.....	72
<i>Касенов А.К., Сыздыков А.Х., Спиринов В.И., Молдабеков М.С., Букенова М.С.</i> Методика расчета кавитаторов для устройств конструкции Satbayev University по очистке нефтегазовых скважин.....	81
<i>Кенжалиев Б., Есимова Д.М., Суркова Т.Ю., Сумовидагдо А., Аманжолова Л.У., Егоров Н.Б.</i> Трансформация соединений редкоземельных и примесных элементов в процессе изменения рН продуктивного раствора.....	87
<i>Корнев В.А., Макенов А.А., Машекенова А.Х., Раджабов Р.К.</i> Оценка качества мультипараметрического контроля работоспособности сложных систем автомобиля.....	96
<i>Лагутин Е.И., Смоляр В.А., Кожобаев К.А., Терехов А.Г., Едигенов М.Б.</i> Вероятностные гидрогеологические карты.....	103
<i>Муртазин Е.Ж., Мирошниченко О.Л., Трушель Л.Ю., Смоляр В.А., Мирлас В.М.</i> Создание компьютерных макетов карт обеспеченности Казахстана подземными водами.....	114
<i>Мустафаев Ж.С., Козыкеева А.Т., Калмашова А.Н., Алдиярова А.Е., Повилайтис Арвидас</i> Эколого-водохозяйственная оценка водосбора бассейна реки Есиль.....	123
<i>Осипов С.В., Ерменбай А.М., Акылбекова А.Ж., Ливинский Ю.Н., Анарбеков Ойторе</i> Негативное воздействие антропогенных факторов на состояние подземных вод Казахстана.....	132
<i>Расулов С.Р., Гасанов Г.Т., Зейналов А.Н.</i> Акустическое диагностирование реологических свойств нефти в скважине.....	141
<i>Солоненко В. Г., Махметова Н.М., Николаев В.А., Квашинин М.Я., Базанова И.А., Джолдасова К.К.</i> Влияние положения точки приложения поезда нагрузки на величину боковой силы.....	148
<i>Ключко Р.Н., Джумашев Г.С.</i> Пробационный контроль в отношении лиц, подлежащих условно-досрочному освобождению.....	156
<i>Тайсарина А.С., Телтаев Б.Б., Лопренчиче Д., Ибрагимова Н.А.</i> Анализ взаимосвязи между экономическими, автомобильными, транспортными и логистическими показателями.....	162
<i>Тарихазер С.А.</i> Морфометрический анализ рельефа северо-восточного склона Большого Кавказа с целью туристического потенциала (с использованием ГИС-технологий).....	170
<i>Ходжибергенев Д.Т., Уралов Б.К., Воеводин Е.П., Абдукаримов А., Абсадыков Б.Н.</i> Особенности кинематики процесса бурения.....	178
<i>Хрусталев Б.М., Лю Т., Бусел А.В., Ли Ж., Веренько В.А., Занкович В.В., Шан Б.</i> Оценка и методика прогнозирования структурно-механических свойств композитов на основе гранулятов из переработанных асфальтобетонных дорожных покрытий .....	187

## Юбилейные даты

Жизнь, отданная науке.....	198
----------------------------	-----

**CONTENTS**

<i>Beysenbetov I.K., Bekibayev T.T., Zhapbasbayev U.K., Ramazanova G.I., Panfilov M.</i> SmartTran software for transportation of oil JSC Kaztransoil.....	6
<i>Abdullayev A.U., Yusupov Sh.S.</i> Optimization of quantitative indicators of complex seismo-hydrogeochemical monitoring with the purpose of forecasting strong earthquakes.....	14
<i>Abetov A., Volozh Yu., Niyazova A.</i> Correlation of the structural elements of major geostuctures of North Ustyurt Region.....	21
<i>Baibatsha A.B., Muszynski A.</i> Geological-geophysical prospecting indicators of the Arganaty district predictive blocks (Eastern Balkhash).....	31
<i>Bigaraev A.B., Mussina E.S.</i> State of study, geological structure and oil-and-gas-bearing capacity of the North Kazakhstan sedimentary basin.....	40
<i>Bosak Pavlo, Popovych Vasyl, Stepova Kateryna, Dudyn Roman</i> Environmental impact and toxicological properties of mine dumps of the Lviv-Volyn coal basin.....	48
<i>Goncharenko D.F., Aleinikova A.Y., Ubiivovk A.V.</i> Development of a rehabilitation method for sever tunnels at the junctions to inspection shafts .....	55
<i>Sudakov A., Dreus A., Ratov E., Sudakova O., Khomenko O., Dziuba S., Sudakova D., Muratova S., Ayazbay M.</i> Substantiation of thermomechanical technology parameters of absorbing levels isolation of the boreholes.....	63
<i>Efimenko V.N., Efimenko S.V., Teltayev B.B., Sukhorukov A.V.</i> On the need for differentiated account of properties of the geocomplex of territories in pavements design .....	72
<i>Kassenov A.K., Syzdykov A.H., Spirin V.I., Moldabekov M.S., Bukenova M.S.</i> Methods for calculating cavitators for devices designed by Satbayev University for cleaning oil and gas wells.....	81
<i>Kenzhaliyev B., Yesimova D.M., Surkova T.Y., Soemowidagdo A., Amanzholova L.U., Egorov N.B.</i> Transformation of the rare earth elements and impurity elements combinations in the course of pH pregnant solution modification.....	87
<i>Kornev, V.A. Makenov A.A., Mashekenova A.H., Radjabov R.C.</i> Quality assessment of multi-parameter control of vehicle complex systems efficiency.....	96
<i>Lagutin E.I., Smolyar V.A., Kojabaev K.A., Terekhov A.G., Edigenov M.B.</i> RK probabilistic hydrogeological map.....	103
<i>Murtazin Y.Z., Miroshnichenko O.L., Trushel L.Y., Smolyar V.A., Mirlas V.M.</i> Creation of computer models of the maps of groundwater availability in Kazakhstan.....	114
<i>Mustafayev Zh.S., Kozykeyeva A.T., Kalmashova A.N., Aldiyarova A.E., Povilaitis Arvydas</i> Ecological and water economic assessment of the Yesil river basin catchment area.....	123
<i>Osipov S., Yermenbai A., Akylbekova A., Livinsky Yu., Anarbekov Oitore</i> The negative impact of anthropogenic factors on the state of groundwater of Kazakhstan.....	132
<i>Rasulov S.R., Hasanov G.T., Zeynalov A.N.</i> Acoustic testing of rheological properties of oil in borehole.....	141
<i>Solonenko V.G., Makhmetova N.M., Nikolaev V.A., Kvashnin M.Ya., Bazanova I.A., Joldassova K.K.</i> Influence of appendix point load training on magnitude of side power.....	148
<i>Klyuchko R.N., Dzhumashev G.S.</i> Probational control for persons subject to conditional-early exemption.....	156
<i>Taisarinova Aislu, Teltaev Bagdat, Guiseppa Loprensipe, Ibragimova Nailya</i> Analysis of enterrelation between economic, road, transport and logistic indicators.....	162
<i>Tarikhazer S.A.</i> Morphometric analysis of the relief of the north-eastern slope of the Great Caucasus for the purpose of tourism potential (using GIS technologies).....	170
<i>Khojibergenov D.T., Uralov B.K., Voevodin Ye.P., Abdugarimov A., Absadykov B.N.</i> Features of drilling process kinematics.....	178
<i>Khroustalev B.M., Liu T., Busel A.V., Li Zh., Veranko U.A., Zankavich V.V., Shang B.</i> Estimation and methods of prediction for the structural and mechanical properties of rap-composites.....	187
<b>Anniversary dates</b>	
Life given to science.....	198

---

---

**Publication Ethics and Publication Malpractice  
in the journals of the National Academy of Sciences of the Republic of Kazakhstan**

For information on Ethics in publishing and Ethical guidelines for journal publication see <http://www.elsevier.com/publishingethics> and <http://www.elsevier.com/journal-authors/ethics>.

Submission of an article to the National Academy of Sciences of the Republic of Kazakhstan implies that the described work has not been published previously (except in the form of an abstract or as part of a published lecture or academic thesis or as an electronic preprint, see <http://www.elsevier.com/postingpolicy>), that it is not under consideration for publication elsewhere, that its publication is approved by all authors and tacitly or explicitly by the responsible authorities where the work was carried out, and that, if accepted, it will not be published elsewhere in the same form, in English or in any other language, including electronically without the written consent of the copyright-holder. In particular, translations into English of papers already published in another language are not accepted.

No other forms of scientific misconduct are allowed, such as plagiarism, falsification, fraudulent data, incorrect interpretation of other works, incorrect citations, etc. The National Academy of Sciences of the Republic of Kazakhstan follows the Code of Conduct of the Committee on Publication Ethics (COPE), and follows the COPE Flowcharts for Resolving Cases of Suspected Misconduct ([http://publicationethics.org/files/u2/New\\_Code.pdf](http://publicationethics.org/files/u2/New_Code.pdf)). To verify originality, your article may be checked by the Cross Check originality detection service <http://www.elsevier.com/editors/plagdetect>.

The authors are obliged to participate in peer review process and be ready to provide corrections, clarifications, retractions and apologies when needed. All authors of a paper should have significantly contributed to the research.

The reviewers should provide objective judgments and should point out relevant published works which are not yet cited. Reviewed articles should be treated confidentially. The reviewers will be chosen in such a way that there is no conflict of interests with respect to the research, the authors and/or the research funders.

The editors have complete responsibility and authority to reject or accept a paper, and they will only accept a paper when reasonably certain. They will preserve anonymity of reviewers and promote publication of corrections, clarifications, retractions and apologies when needed. The acceptance of a paper automatically implies the copyright transfer to the National Academy of Sciences of the Republic of Kazakhstan.

The Editorial Board of the National Academy of Sciences of the Republic of Kazakhstan will monitor and safeguard publishing ethics.

Правила оформления статьи для публикации в журнале смотреть на сайте:

**www:nauka-nanrk.kz**

**ISSN 2518-170X (Online), ISSN 2224-5278 (Print)**

**<http://www.geolog-technical.kz/index.php/en/>**

Редакторы *Д. С. Аленов, М. С. Ахметова, Т. А. Апендиев*  
Верстка *Д. А. Абдрахимовой*

Подписано в печать 13.04.2020.  
Формат 70x881/8. Бумага офсетная. Печать – ризограф.  
13 п.л. Тираж 300. Заказ 2.